



Voice Alarm System

EN

Service Manual

EN 54-16: 2008
1438-CPR-0948



ver. 12.2023

Table of contents

1. Safety	7
2. Company presentation	12
3. Demonstration of the smartVES system	13
4. Symbols used in the document	16
5. Warranty conditions	17
6. Requirements	18
6.1 Unboxing	19
6.2 Installation requirements	19
6.3 Environmental conditions	20
7. Devices description	21
7.1 Internal devices	21
7.1.1 Control units	21
7.1.1.1 SMART-CU-8LCD unit	22
7.1.1.2 SMART-CU-11LT unit	25
7.1.1.3 SMART-CU-11LCD unit	30
7.1.2 Central processing unit SMART-DU1604	34
7.1.3 SMART-AMAP-6 Microphone Hub	36
7.1.4 SMART-ANSM-01 measurement microphone	37
7.1.5 Extension cards	38
7.1.5.1 ABT-xCPU – processor card	38
7.1.5.2 ABT-xNET-1Gb/WAN/RS – communication card	40
7.1.5.3 ABT-xLogIN-8f – logical input card for function slot	43
7.1.5.4 ABT-xLogIN-8c – logical input card for control slot	45
7.1.5.5 ABT-xLogOUT-8f – logical output card for function slot	45
7.1.5.6 ABT-xLogOUT-8c – logical output card for control slot	47
7.1.5.7 ABT-xAUDIO-4/8-RS – audio input / output card with RS485	47
7.1.5.8 ABT-xAUDIO-8 - 8 audio input card for function slot	50
7.1.5.9 ABT-xCtrLine-4 – 4 loudspeaker lines control card	51
7.1.5.10 ABT-xCtrLine-2 – 2 loudspeaker lines control card	53
7.1.5.11 SMART-xCtrLine-44 - 4 loudspeaker lines control card	56
7.1.6 Power amplifiers	57
7.1.6.1 Front panel	58
7.1.6.2 Front panel operation	58
7.1.6.3 Rear panel	60
7.1.6.4 Detailed description of selected functions	62
7.1.6.5 Bridging	62

7.1.6.6	Initial commissioning	63
7.1.6.7	Technical data	64
7.1.6.8	Service	67
7.1.6.9	Usage recommendations	67
7.1.6.10	Manufacturer's notes	67
7.1.7	ABT-ISLE audio/RS interface	68
7.1.8	SMART-PSM48/E Power Supply Manager	69
7.1.8.1	Unpacking the equipment	69
7.1.8.2	Installation	70
7.1.8.3	Installation and connection	71
7.1.8.4	Front panel	73
7.1.8.5	Front panel operation	74
7.1.8.6	Rear panel	76
7.1.8.7	Initial start-up	79
7.1.9	SMART-PS48800 Power Supply Unit	80
7.1.9.1	Rear panel	80
7.1.9.2	SMART-PF4 power supply frame	81
7.2	External devices	82
7.2.1	ABT-DFMS Fireman's microphone	82
7.2.2	ABT-DMS zone microphone	86
7.2.3	ABT-DMS-LCD zone microphone with LCD	89
7.2.4	ABT-EKB-20M microphone keyboard extension	92
7.2.4.1	Functions carried out by function keys	93
7.2.4.2	SSignalling related to the function keys	93
7.2.4.3	Connecting a microphone and keyboard extension	94
7.2.5	Noise sensing controller – ABT-NSC6	96
7.2.6	ABT-EOL end-of-line supervision module	98
8.	System hardware installation	99
8.1	Information on limiting damage consequences	100
8.2	General connection diagram	100
8.3	Connecting devices	101
8.3.1	Schemat urządzenia smartVES	102
8.3.2	Control units	103
8.3.2.1	Daisy chain Topology	103
8.3.2.2	Ring topology	104
8.3.3	Amplifiers	105
8.3.3.1	Individual connection without backup channel with SMART-CU-8LCD	105
8.3.3.2	Individual connection without backup channel with SMART-CU-11LT / SMART-CU-11LCD	106
8.3.3.3	Connection with 100 V internal buses for SMART-CU-8LCD	107
8.3.3.4	Connection with 100 V internal buses for SMART-CU-11LCD / LT	108

8.3.3.5	Individual connection with backup channel for SMART-CU-8LCD	109
8.3.3.6	Individual connection with backup channel for SMART-CU-11LT / SMART-CU-11LCD	110
8.3.4	Power supply	111
8.3.4.1	Batteries	112
8.3.5	Microphones	116
8.3.5.1	Ring-type optical fibre connection for firefighter's microphone	116
8.3.5.2	Daisy chain cable connection for firefighter's microphone	116
8.3.5.3	Fireman's and zone microphone cable connection using the LAN/WAN port on the front panel	117
8.3.5.4	Power supply for the fireman's microphone	118
8.3.5.5	Zone microphones - connection types	119
8.3.5.6	Power supply for zone microphones	122
8.4	Preparing the installation for VAS commissioning	124
9.	Operation modes – LED colors	126
9.1	Normal mode	128
9.2	Alarm mode	128
9.3	Failure mode	128
9.4	Lock mode	128
10.	Instruction for performing tests and trials	129
10.1	Instructions for performing basic functions	129
10.1.1	Alarm mode	129
10.1.2	Failure mode	130
10.1.3	Controlling backup power batteries	130
10.2	Testing the system	130
11.	Operation instructions	132
11.1	Control Unit	132
11.2	Fireman microphone	132
11.3	Zone microphone	134
11.4	Power supply manager	134
12.	Maintenance and service	135
12.1	Preparations before VAS system maintenance works	135
12.1.1	Initial procedures for system testing	135
12.1.2	System testing	135
12.2	System maintenance	137
12.2.1	Daily review	137
12.2.2	Inspection every 6 months	137
12.2.3	Annual inspection	138
12.2.4	Manufactures remarks	138
13.	smartVES Configuration Software	139
13.1	Welcome screen	139

13.2	Basic Configuration	140
13.3	System Configuration	142
13.3.1	File	143
13.3.2	Preferences	144
13.3.3	System	145
13.3.4	System Connection Settings	146
13.3.5	Workspace	148
13.3.6	System Configuration	149
13.3.7	SMART-AMAP-6 concentrator and SMART-DU-1604 processor	150
13.3.8	DFMS	157
13.3.9	DMS	160
13.3.10	DMS-LCD	162
13.3.11	NCS6 Configuration	163
13.3.12	xCtrlLine-2/4	168
13.3.13	xLogIN-8c/f	169
13.3.14	xLogOUT-8c/f	170
13.3.15	Audio-4/12	171
13.3.16	xNET-1Gb/WAN/RS	175
13.4	Description of backup functionality for smartVES system	181
13.5	Priority Manager Configuration	182
13.6	Group Zone Configuration	184
13.7	Control I/O Configuration	185
13.7.1	Group Logical Inputs	185
13.7.2	Group Logical Outputs	186
13.7.3	Timers	188
13.8	Matrix Configuration	189
13.9	Scenario Configuration	191
13.10	Event Configuration	193
13.10.1	Functions	195
13.11	System notifications	200
13.12	Reports	203
13.13	Basic steps required for programming of the system	204
13.14	Glossary	210
13.15	FAQ	212
13.16	Appendix	215
14.	smartVES system touchscreen user manual	221
14.1	Home screen (screen saver)	221
14.2	Lock screen	221
14.3	System Options	222
14.4	Fire zones	223

14.5 Numerical selection of fire zones	225
14.6 Fire zone groups	227
14.7 Service	228
14.8 Fault register	231
14.9 Interface setting	233
15. Annexes	234
16. Certificates	235
17. Glossary	236
18. List of tables	237
19. List of drawings	238

1. Safety



Danger!

High risk: this symbol indicates an imminently hazardous situation, such as high high voltage inside the product housing. If this situation occurs, there is a risk of electric shock, serious injury or death.



Warning!

Medium risk: indicates a potentially hazardous situation. If not avoided, this could result in minor or moderate bodily injury.



Caution!

Low risk: indicates a potentially hazardous situation. If this situation arises, there is a risk of material damage or damage to the device.

- 1 **Read the following instructions.** Before using the device or system, read all safety and operating instructions.
- 2 **Keep these instructions.** Keep safety instructions and operating manuals for future reference.
- 3 **Follow all warnings.** Observe all warnings on the unit and in the operating instructions.
- 4 **Follow all instructions.** All instructions for installation or use/operating should be followed.
- 5 **Do not use this equipment near water.** Do not use this appliance near water or in a humid environment - for example, near a bathtub, wash basin, kitchen sink, laundry sink or in a damp basement, near a swimming pool, in an unprotected outdoor installation or anywhere that is classified as humid.
- 6 **Use only a dry cloth for cleaning.** Unplug the unit from the electrical outlet before cleaning. Do not use liquid or aerosol cleaners.
- 7 **Do not block the ventilation holes. Carry out the installation in accordance with the manufacturer's instructions.** Any holes that may be in the housing are intended to provide ventilation and thus reliable operation of the device and protection against overheating. These openings must not be blocked or covered. The equipment may only be installed in a built-in unit if proper ventilation is ensured and the manufacturer's instructions in this respect are followed.
- 8 **Do not install the equipment near heat sources such as radiators, hot air vents, cookers or other equipment (including amplifiers) that generate heat, or where the equipment is exposed to direct sunlight.**
- 9 **Do not place flame sources such as lighted candles on the equipment.**
- 10 **Do not defeat the safety purpose of the polarized or ground-type plug.** A polarized plug has two blades with one wider than the other. A grounding type plug has two blades and a third grounding prong. The wider blade or the third prong are provided for your safety. If the provided plug does not fit into your outlet, consult an electrician for replacement of the obsolete outlet.
- 11 **Protect the power cord from being stepped on or kinked, especially at the plug, the electrical outlet and at the point of exit from the device.**
- 12 **Only use accessories/parts recommended by the manufacturer.** The equipment must be assembled in accordance with the manufacturer's instructions. In addition, use mounting accessories recommended by the manufacturer.
- 13 **Use only trolleys, stands, tripods, brackets or mounting tables recommended by the manufacturer or sold with the equipment.** Extreme caution should be exercised when transporting equipment mounted on a trolley, as an overturning trolley can cause injury. Abrupt stops, excessive force, and movement over uneven surfaces may cause the cart with the equipment to tip over.
- 14 **Disconnect the equipment from the power supply during a thunderstorm or when not using it for a long period of time.** This does not apply if specific functions must be maintained, for example emergency systems.

- 15 **Have service performed by qualified service personnel.** Servicing is required when the equipment has been damaged in any way, such as the power-supply cord or plug having been damaged, liquid has been spilled or foreign bodies have fallen into the unit, the unit has been exposed to rain or moisture, does not operate normally, or has been dropped.
- 16 **Avoid mechanical shocks.** Strong impacts and shocks can damage the apparatus. Handle and carry the equipment carefully, avoiding dropping it.
- 17 **Do not allow drops of water to fall on the unit or place liquid containers on the unit.**
- 18 **Do not expose the batteries (battery pack or batteries contained in the equipment) to excessive heat caused, for example, by sunlight or fire.**



Caution! There is a risk of explosion if the battery is replaced incorrectly. Replace the battery only with a battery of the same type or equivalent. Dispose of used batteries in accordance with environmental regulations and procedures.

- 19 **Professional installation only.** Do not use this device in residential areas.
- 20 **Condensation.** To avoid condensation, wait a few hours before switching on the appliance if it has been transported from a cold to a warm place.
- 21 **Hearing damage.** In the case of a device with audio output, in order to prevent hearing damage, the emitted sounds should not be listened to for a long time at a high volume setting.
- 22 **Do not disassemble the device or attempt to repair or modify it.** The equipment does not contain any user-serviceable parts for disassembly or repair. For maintenance and servicing of the equipment, contact qualified service personnel. Opening the unit's housing yourself or tampering with internal components voids the warranty. Use of unauthorised spare parts may result in fire, electric shock or other hazards.
- 23 **Security check.** After servicing or repairing the appliance, ask a service technician to carry out a safety check to determine whether the appliance is operating correctly.



Danger! Overloading – do not overload outlets and extension cords as this can result in a risk of fire or electric shock.

- 24 **Power sources.** The power supply to the unit must be of the type indicated on the rating plate. If you are unsure of the power supply, consult your appliance distributor or local power company. If the device is intended to be powered from a battery, follow the instructions for use.
- 25 **Power lines.** The outdoor system should not be placed near overhead power lines, lampposts or power circuits or where it could fall on such power lines or circuits. When installing the system outdoors, the utmost precautions must be taken to avoid touching power circuits or lines, as there is a risk of death.



Danger! Objects and liquids inside the unit – no objects may be inserted into the openings in the appliance as they may come into contact with high voltage areas or parts that can cause a short circuit and consequently cause a fire or electric shock. Do not spill any liquid on the unit.

- 26 **Indirect protective earthing.** An appliance of Class I construction must be connected to a power outlet with a protective earthing connection.

Direct protective earthing. An appliance of Class I construction must be connected to a mains socket outlet with a protective earthing connection.

Note on connecting to a power source:

- » For permanently connected appliances, a readily accessible mains plug or all-pole power disconnect should be fitted outside the appliance and comply with all applicable installation rules.
- » For pluggable equipment, the socket-outlet shall be installed near the equipment and shall be easily accessible.



CAUTION
RISK OF ELECTRICAL SHOCK
DO NOT OPEN



This label can be located on the bottom of the device due to limited space.



Caution! To reduce the risk of electrical shock, DO NOT open covers. Refer servicing to qualified service personnel only.



Warning! To prevent fire or shock hazard, do not expose units to rain or moisture.



Warning! Installation should be performed by qualified service personnel only in accordance with the National Electrical Code or applicable local codes.



Warning! Power supply disconnection: If the unit is connected to the mains power supply and the mains power cord is part of the unit, the power supply will be disconnected from the mains plug. If an AC/DC power adapter is included and the mains plug is part of the unit, power is disconnected via the AC/DC adapter. The mains power outlet should be located in an easily accessible place close to the appliance.



Old electrical and electronic equipment

Electrical and electronic devices that are no longer in use should be handed in for disposal at the appropriate treatment facilities (in accordance with the EU Waste Electrical and Electronic Equipment Directive). To dispose of old electrical and electronic equipment, please use the appropriate take-back and collection system used in your country.



Use only at altitudes not exceeding 2000 m.



Use only in non-tropical climate regions.



Deklaracja właściwości użytkowych

Declaration of Performance

Nr/No smart-20230925

1.	Produkt Product	Centrala Dźwiękowego Systemu Ostrzegawczego smartVES Emergency Sound System smartVES
2.	Niepowtarzalny kod identyfikacyjny typu wyrobu Type of construction product	<p>Elementy składowe: / Components: SMART-CU8LCD / SMART-CU8LCD R / SMART-CU11LT / SMART-CU11LCD / SMART-DU1604 / ABT-DFMS / ABT-DMS / ABT-DMS-LCD / ABT-EKB-20M / ABT-xCPU / ABT-xNET-1Gb-WAN-RS / ABT-xLCD / ABT-xAudi-8 / ABT-xAudio-4/8-RS / ABT-ISLE / ABT-xCtrLine-2 / ABT-xCtrLine-4 / SMART-xCtrLine-44 / ABT-xLogOUT-8(c/f) / ABT-xLogIN-8(c/f) / ABT-PA8080B_BE / SMART-PA8080_E / ABT-PA8160B_BE / SMART-PA8160_E / ABT-PA4160B_BE / SMART-PA4160_E / ABT-PA2650B_BE / SMART-PA2650_E / ABT-PA1650B_BE / SMART-PA1650_E / SMART-PS48800 / SMART-PSM48_E / SMART-PF4 / ABT-EOL / ABT-REG1 / LM8200 / TF-06-01 / ABT-NSC6 / ABT-NSM A_B / SMART-AMAP-6 / SMART-ANSM-01 / DCN S5750E / Netgear series S350 / GS108PE_PP / GS308PP / GS110TPv3 / GS116LP_PP / CTC VDTU2-B140 D / ABT-ISE-GATEWAY / SF-MM31/55WD055D-GP / SF-MM31/55WD055-GP / SF-MMS31/55WD055D-GP / SF-MMS31/55WD055-GP / SF-SM31/55WD020D-GP / SF-SMS31/55WD020D-GP / SF-SMS31/55WD020-GP / SF-CP100C-GP / SF-MM31002D-GP / SFP-1GBT-06</p>
3.	Numer typu, partii lub serii lub jakikolwiek inny element umożliwiający identyfikację wyrobu budowlanego Type, batch or serial number or any other element allowing identification of the construction product	Zobacz etykietę znaku CE i oznaczenia na tabliczce See CE mark label and marking on boards
4.	Zamierzone zastosowanie Declared intended use of product	Bezpieczeństwo pożarowe Fire Safety
5.	Producent Manufacturer	Ambient System Sp. z o.o. ul. Bysewska 27, 80-298 Gdańsk, Polska
6.	System oceny i weryfikacji stałości użytkowych System of AVCP	1
7.	Jednostka notyfikowana Notified body	CNBOP-PIB nr/no. 1438 1438-CPR-0948 z dnia/from 28.08.2023

Example of smartVES system rating plate

smartVES Nr seryjny / Serial Number:		  23
EN 54-16 – Certyfikat zgodności // Certificate of constancy of performance	1438-CPR-0948/W	
Certificate of compliance	DC-UAE-0258	 Producent / Manufacturer: Ambient System Sp. z o.o. Gdańsk 80-298, ul. Bysewska 27
Świadectwo dopuszczenia CNBOP-PIB // Certificate of admission CNBOP-PIB	5069/2023	
Deklaracja właściwości użytkowych // Declaration of Performance	smart-20230925	
Przeznaczenie // Declared intended use of product	bezpieczeństwo pożarowe // fire safety	
Zgodny z normą // Comply with	EN 54-4 / EN 54-16	
Stopień ochrony IP // Ingress Protection Rating	30	
UZS SMART	EN 54-4: 1438-CPR-0948/W • ŚD CNBOP-PIB: 5069/2023	

Environmental impact of the product



This product has been labelled in accordance with the WEEE Directive (2002/96/EC) and subsequent amendments, concerning waste electrical and electronic equipment. By ensuring that this product is disposed of correctly, you are helping to reduce the risk of negative effects on the environment and human health that could occur if the product is disposed of incorrectly. The symbol on the product or on the accompanying documents indicates that our product is not classified as household waste. The device should be taken to an appropriate waste disposal facility for recycling. For further information regarding the recycling of this product, please contact your local authority representative, your waste disposal service provider or the shop where you purchased the product. In accordance with the Waste Electrical and Electronic Equipment Act of 29 July 2005, it is not permitted to dispose of waste electronic equipment together with other (municipal) waste, as penalties exist for such actions. The appliance packaging components are made of cardboard and polyethylene foam, so they can be recycled after use. To this end, unnecessary packaging should be sorted according to its purpose and delivered to the nearest waste collector.

In the interest of protecting human health and the environment, we ensure that our products, which are subject to the RoHS Directive 2011/65/EU on the use of hazardous substances in electrical and electronic equipment, have been designed and manufactured in compliance with the requirements of this Directive.

2. Company presentation

With more than twenty years of experience, Ambient System has quickly established itself as a leading manufacturer of Public Address, Voice Alarm systems and counter intercoms. The constant growth of market share in Europe provides confirmation of the quality of Ambient System commercial and technical approach.

Products:

The company currently offers a full range of sound equipment: microphones, loudspeakers, preamplifiers, digital audio matrices, loudspeaker monitoring systems, power supply systems, amplifiers. Ambient System designs and manufactures leading products in the market of sound alarm systems, certified in accordance with the PN-EN 54-4, PN-EN 12101-10, PN-EN 54-16, PN-EN 54-13, PN-EN 54-24 standards. Our products meet the requirements of the electromagnetic compatibility directive EMC 2004/108/EC AND the low voltage directive LVD 2006/95/EC.

Development:

Thanks to our R&D team and continuous investment, we can respond quickly to the demands of different markets, providing specific solutions and the latest technology. We have sales representatives operating in many countries in Europe and the Middle East, with whom we have already carried out many major projects.

By choosing Ambient System, you are tying yourself to a guaranteed, trustworthy partner that you can rely on in the long term.

Ambient System's application areas:

Our sound systems are used in the following areas:

- » railway,
- » subway,
- » airports,
- » high-rise buildings,
- » hotels,
- » restaurants,
- » shopping malls,
- » amusement parks,
- » places of worship,
- » stadiums,
- » museums,
- » industrial buildings,
- » industrial plants,
- » commercial buildings,
- » tunnels,
- » military facilities.

3. Demonstration of the smartVES system

SmartVES is the latest product from Ambient System, a company specialising in the manufacture of reliable, certified voice evacuation systems. SmartVES is a networked Public Address & Voice Evacuation system based on fibre optic digital transmission of both voice, emergency, and commercial messages.

The control panel of the smartVES VAS (Voice Alarm System) was designed in accordance with European standard EN 54-16.

According to the internal rules of CEN/CENELEC, the standardisation organisations of the following countries are required to implement this European standard:

Austria, Belgium, Bulgaria, Cyprus, Czech Republic, Denmark, Estonia, Finland, France, Germany, Greece, Hungary, Iceland, Ireland, Italy, Lithuania, Latvia, Luxembourg, Malta, Netherlands, Norway, Poland, Portugal, Romania, Spain, Slovakia, Slovenia, Sweden, Switzerland and United Kingdom.

The smartVES system includes: control units, multi-channel amplifiers, as well as firefighter microphone units and zone microphones. All components are certified. At the heart of the system is a state-of-the-art platform that enables digital, scalable communication between all system components, as well as between other integrated safety systems.

The smartVES system is designed for a variety of applications - well suited for both decentralised and centralised systems..

The system architecture is based on a fibre-optic connection between the control unit devices and other system components. This makes it possible to realise the most area- and functionally extensive facilities, for example: airport terminals, oil fields and refineries, shopping centres or office complexes.

At the same time, in combination with the customisable design of the control units and the multi-channel and network capability of the amplifiers, we can create compact systems for individual small and medium-sized facilities as well as their larger groups connected by a digital network.

The following components are part of the smartVES integrated VAS central unit concept:

SMART-CU-8LCD - Control unit

SMART-CU-11LT - Control unit

SMART-CU-11LT-LCD - Control unit

ABT-xLogIN-8f - Logical input card for function slot

ABT-xLogOUT-8f - Logical output card for function slot

ABT-xAUDIO-4/8-RS - 4 audio inputs and 8 audio outputs card for function slot

ABT-xAudiI-8 - 8 audio input card for function slot

ABT-xCtrLine-2 - 2 loudspeaker lines control card

ABT-xCtrLine-4 - 4 loudspeaker lines control card

SMART-xCtrLine-44 - 4 loudspeaker lines control card

ABT-xLogIN-8c - Logical input card for control slot

ABT-xLogOUT-8c - Logical output card for control slot

SMART-PA8080 - Power amplifier

SMART-PA8160 - Power amplifier

SMART-PA4160 - Power amplifier

SMART-PA2650 - Power amplifier

SMART-PA1650 - Power amplifier

SMART-PA8320 - Power amplifier

SMART-PA21300 - Power amplifier

SMART-PA11300 - Power amplifier

SMART-PA4320 - Power amplifier

ABT-ISLE - Audio interface

SMART-PSM48 - Power supply manager

SMART-PS48800 - Power supply

ABT-DFMS - Fireman's microphone

ABT-DMS - Zone microphone

ABT-DMS-LCD - Zone microphone with display

ABT-EKB-20M - Microphone keyboard extension

DEHNrail DR M 2P 150 - Speaker line surge arrester

ABT-REG1 - Volume controller

ABT-NSC6 - Background microphone controller

SMART-DU1604 - Adaptive audio processor

SMART-AMAP-6 - Adaptive microphone aggregation point

SMART-ANSM-01 - Adaptive noise-sensing microphone

Optional features in accordance with EN 54-16 standard:

Acoustic signalling	x
Voice alarm delay	✓
Phased evacuation	✓
Manual voice alarm muting	✓
Manual voice alarm cancelling	✓
Outputs for fire alarm devices	✓
Voice alarm status output	✓
Fault signalling related to the transmission path to the FAS	✓
Fault signalling associated with voice alarm zones	✓

Blocking status	✓
Manual voice alarm control	✓
Digital interface between VASCU and external control devices	✓
Emergency microphones	✓
Backup power amplifiers	✓

4. Symbols used in the document

**Warning!**

This sign indicates a potentially dangerous situation, threatening death or disability.

**Attention!**

This sign indicates a potentially dangerous situation with the risk of moderate or minor injury to persons and/or damage to property.

**Warning!**

This sign indicates that the use of the above products increases the risk of damage to the eye.

5. *Warranty conditions*

Warranty conditions are part of General Terms & Conditions of Delivery available at www.ambientsystem.eu/en

6. Requirements

Unused devices must be stored in the original packaging, in enclosed rooms with the ambient temperature ranging from -20°C to 70°C and relative humidity – from 5% to 95% (without condensation).

When the unit is moved from a cold to a warm environment, there is a risk of condensation, which has a negative impact on the performance of the unit. In this case, leave the appliance to adjust to the new environment for approximately one hour before starting work. one hour before starting work.

During transport, the equipment should be packed in such a way as to reduce the risk of mechanical damage and the impact of atmospheric conditions.

The recommended size of RACK cabinets is 600 × 800 (width × depth), the height used is 24 [U], 33 [U], 42 [U], 45 [U]. Please note that the height of the enclosure (U) depends on the system being designed.

The space required between units to maintain adequate air circulation is shown in the table below.

RACK cabinet UNIT	UNIT height [U]	SPACE [U]	TOTAL [U]
SMART-CU-8LCD	2	1	3
SMART-CU-11LT	2	1	3
SMART-CU-11LCD	2	1	3
SMART-PA8080	2	0	2
SMART-PA8160	2	0	2
SMART-PA2650	2	0	2
SMART-PA8320	2	0	2
SMART-PA21300	2	0	2
SMART-PA11300	2	0	2
SMART-PA4320	2	0	2
SMART-PAPSM48	2	0	2
SMART-PF4	2	0	2
SMART-DU1604	1	0	1

The space needed for the batteries may vary depending on the manufacturer. However, always keep a minimum distance of 2 [U] in order to maintain adequate air circulation.

6.1 Unboxing

Please read this manual to familiarise yourself with the relevant information regarding the installation, operation and characteristics and functions of the product. If the product has to be returned to a service centre, it is required to pack the device in the original packaging (or packaging identical to the original).

6.2 Installation requirements

The alarm centre room in which the VASCU is located must meet the following conditions:

- » The fire equipment service room (FPDOR) should be located on a floor of the building, close to the entrance/exit provided and marked as an entrance for rescue teams.
- » The room should be located and marked in such a way that it is visible when entering the facility through the entrance provided for rescue teams. It is recommended that the entrance door to the FPDOR should not be more than 10 m from the exit for the rescue teams.
- » Access to the room should be at least 1.5 m wide.
- » The room should be appropriately marked.
- » If a FPDOR is located other than 10 m from an exit for rescue teams, additional signs should be used to indicate the location and direction of access to that FPDOR.
- » The Fire Safety Instructions in graphics and site evacuation procedures should include signs and location of FPDOR.
- » A Manual Call Point should be installed in or in the immediate area of the FPDOR. The FPDOR should be monitored by automatic detectors included in the facility's fire alarm system.
- » Access to the FPDOR should be restricted to authorised persons and emergency services only. A method by which the door is locked is permitted, provided that one key is in a suitably marked box with breakable glass, fixed to the wall adjacent to the door to the room.
- » FPDOR should be an enclosed room with walls and ceilings with a fire resistance class of REI 60. FPDOR doors should have a fire resistance class of EI30.
- » The console with the firefighter's microphone should be connected to the VASCU via wires ensuring circuit continuity under fire conditions.
- » Natural and artificial lighting should be provided. The illumination intensity in the room should be min. 500 lux.
- » The room shall be equipped with emergency lighting with an average illuminance of at least 10 lux.
- » Climatic conditions must meet the following requirements: temperature between 0°C and +40°C, relative humidity between 25% and 80%, air pressure between 860 hPa and 1060 hPa.
- » Adequate space should be provided near the front panel of the VASCU to allow the required manipulations to be carried out.
- » The installation height of the VASCU control and indication devices should allow for proper operation.
- » The background level in the room where the console with the firefighter's directional microphone is located should not exceed 40dB.
- » There should be a table in the room sized to lay out the facility and system documentation.

6.3 *Environmental conditions*

Do not place the product in an environment that may negatively affect the functioning of the device or reduce its correct operation time. Environments that affect the equipment negatively are usually characterised by high levels of temperature, dust, humidity and vibration. Equipment should be placed in a cool, dry location away from direct sunlight and from flammable and explosive materials.

As the main source of distributed power, external 800 W SMART-PS48800 switched-mode power supply modules are used. The SMART-PSM48 power manager can work with up to four power supply modules, ensuring that they are securely connected for operation and controlling the output parameters of each power supply. When using the system solely as a backup power supply system, there is no need for power supplies. The power supplies must be mounted in a dedicated SMART-PF4 frame, which must then be bolted inside the enclosure with the screws provided. The elements of the system are designed to be mounted in a 19" RACK cabinet with a minimum of IP30, in which other elements of the fire detection system and the fire warning system are also built in.

Optionally, the SMART-PS48800 power supply can be used as a stand-alone unit without being mounted in the SMART-PF4 power supply frame and RACK cabinet. Similarly, the SMART-PSM48800 power distributor can also be used as a standalone unit. It is then necessary to ensure that the installation location of the equipment has been selected with regard to the permissible operating parameters. The power supply should operate in an ambient temperature of 5 to +40°C.

The maximum configuration of one VAS power supply system complying with EN 54-16 includes:

- » 1 × SMART-PSM48 – power supply manager,
- » 4 × SMART-PS48800 – power supply modules,
- » 1 × SMART-PF4 – power supply unit frame.

7. Devices description

This section describes the following components of the smartVES system:

- » Control units,
- » Extension cards,
- » Power amplifiers,
- » Connection isle,
- » Power supply manager,
- » Power supply unit,
- » Microphones and microphone keyboard extensions,
- » Adaptive audio processor,
- » Adaptive microphone aggregation point,
- » Adaptive noise-sensing microphone.

7.1 Internal devices

7.1.1 Control units

The control unit is the main component of the system that receives the audio signal from the sources and transmits it to the entire system. This unit manages all other components. This component allows flexible configuration of audio signal paths from any source to any output. Global switching of the audio paths is implemented using programmable logic and an Ethernet 1G type network (UDP/IP, TCP/IP).

The smartVES system offers three different control units:

- » **SMART-CU-8LCD unit:**
 - › The unit is factory-equipped with an xCtrlLine-4 control card, an xAUDIO-4/8-RS audio card and an xLogIN-8f 8 logic input card. The basic ABT-xCPU 100Mb/s network card does not allow networking with other units in the system. For this purpose, the unit must be equipped with an ABT-xNET-1Gb/WAN/RS network card (optional).
 - › The unit is designed for small VAS systems (stand-alone version). It has both control and 4 function slots to increase the supported audio inputs/outputs.
- » **SMART-CU-11LT unit:**
 - › The unit is factory-equipped with an ABT-xNET-1Gb/WAN/RS communication card, which allows any networking with other units in the system, either via CAT5e/6 twisted-pair cables or optical fibre. In addition, the CU-11LT has 4 audio inputs, 12 audio outputs and 11 slots for free-form filling with logic input/output cards and speaker line control cards.
- » **SMART-CU-11LCD unit:**
 - › Similar to the SMART-CU-11LT, it additionally has an integrated LCD screen.

The system components operate with a resolution of 48KHz / 32 bits / 2 channels. Communication between devices over long distances (from 500 metres to 20 km) is realised using 1000BASE-X technology (optical fibre), and thanks to 2 ports with SFP modules, connection redundancy is ensured. The use of ports with RJ45 connectors is recommended when combining devices located in a single rack. The available ports are:

- » 1000BASE-TX / RJ45 - CAT5E cables - 2 ports available on the rear panel of the device / communication card;

- » 100BASE-TX / RJ45 - CAT5 cables - 1 port available on the rear panel for connecting an external WAN, and a computer with configuration software installed.

Fibre optic connections are implemented using SFP modules. This will ensure that the components of the fibre optic system can be selected independently and costs can be reduced for a system that does not use fibre optic connections.

SMART-CU-8LCD control unit components:

- » 1 × main backplane,
- » 1 × control backplane,
- » 1 × processor card with LAN/WAN 100 Mb/s connection,
- » 1 × communication card (optional),
- » 1 × GUI module,
- » 1 × xCtrlLine-4 control card,
- » 1 × xAudio-4/8-RS,
- » 1 × xLogIN-8f.

Components of the SMART-CU-11LT and SMART-CU-11LCD control unit:

- » 1 × passive backplane,
- » 1 × GUI module (optional),
- » 1 × audio card with 4 audio inputs and 12 audio outputs,
- » control backplane for 11 cards (optional).

7.1.1.1 SMART-CU-8LCD unit

The SMART-CU-8LCD control unit is equipped with a 4.5" colour LCD touchscreen display, which provides direct access to the management and monitoring functions of the entire system. The SMART-CU-8LCD is an input signal matrix mixer. It assigns input signals to four internal 100 V audio buses, a 28-channel digital system bus or directly to the unit's audio outputs. The SMART-CU-8LCD acts as a stand-alone smartVES system controller, which cannot be networked with other control units without the use of an additional xNET-1Gb/WAN/RS card.

The unit has two types of slots: function and control, located on the rear panel. Up to 2 audio input, audio output or logic cards can be plugged into the function slots in addition to the factory-fitted ones:

- » ABT-xAudio-4/8-RS,
- » ABT-xAudI-8,
- » ABT-xLogIN-8f,
- » ABT-xLogOUT-8f.

Up to 7 loudspeaker line control cards or logical inputs/outputs can be plugged into the control slots:

- » ABT-xCtrlLine-4,
- » ABT-xCtrlLine-2,
- » ABT-xLogIN-8c,
- » ABT-xLogOUT-8c.

SMART-CU-8LCD control unit controls audio signal addressing, priorities and external devices. Switching audio tracks is performed on the basis of programmable logic system and Ethernet 1G (UDP/IP, TCP/IP) network. Programming input and output signal settings is possible via the computer (PC). Thanks to SMART-CU-8LCD possibilities which are connected to the software, it is possible to archive the list of up to 100 000 events and failures to read them on PC or print out afterwards.

Table 1. SMART-CU-8LCD technical data

Model	SMART-CU-8LCD
Power supply	48V DC (operating range 40-57 V DC), connector with M2.5 screw terminals, distance between partitions 5.08 mm
Number of slots for function cards	4
Number of slots for control cards	8
Messages	SDHC cards up to 32 GB supported; SDHC SLC 512 MB cards included which provide 20 minutes of messages
Display	4.5" LCD colour touch screen
DSP	8-band equalizer, limiter and delay line on each audio output of the control unit, 3-band equalizer on each audio input of the control unit
Data communication	<p>long-distance communication between devices:</p> <ul style="list-style-type: none"> › 1000BASE-X over fibre › 2 ports for redundant connection <p>communication between devices installed next to each other:</p> <ul style="list-style-type: none"> › 1000BASE-TX / RJ45 over CAT5E cables - 2 ports available on the rear panel of the unit › 100BASE-TX / RJ45 over CAT5 cables - 1 port available on rear panel for external network connection (see notes)
Communication with PC	PC (commissioning software); RJ45 connector, twisted pair connections in TIA/EIA-568-B standard via Ethernet protocol
Fiber module – connector type	SFC type modules, SC/LC type connector, multimode or single-mode optical fibre, E30 or E90, OM1 or OM2
Operating temperature	0°C / +60°C
Operating humidity	15% to 80% (non-condensing)
Storage temperature	-20°C / +70°C
Storage humidity	15% to 80% (non-condensing)
Enclosure finish	case material: steel; front panel made of black painted metal plate
Dimensions	482 (W) × 85 (H) × 325 (D) mm
Accessories	2 rack mounting brackets and 4 rack mounting screws, 8 blanking plugs, power supply connector and 100V BUS connector

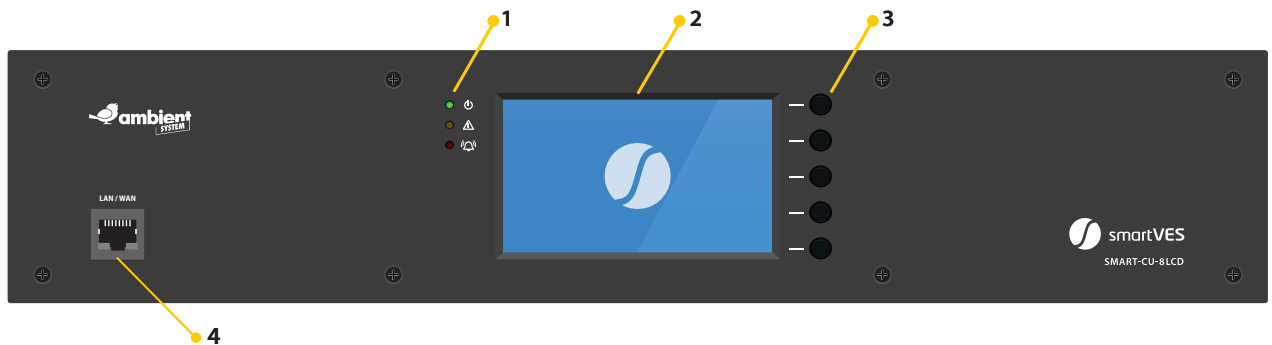

Drawing 1. SMART-CU-8LCD front panel

1. **Indicators:**
 - a. Power supply indicator (green LED)
 - b. Fault indicator (yellow LED)
 - c. Alarm mode indicator (red LED)
2. **Display - shows the control unit menu**
3. **Function buttons for navigating the device menu:**
 - a. HOME - press to return to the main menu,
 - b. ENTER – press to select item in the menu,
 - c. ↑ - up arrow – press to navigate in control unit menu,
 - d. ↓ - down arrow – press to navigate in control unit menu,
 - e. BACK – press to return to previous item in the control unit menu.
4. A connection to a PC via the front LAN/WAN port is required to program the SMART-CU8-LCD control unit not equipped with the optional ABT-xNet-1Gb/WAN/RS card.

Because front port is LAN port with hidden WAN function to establish connection the IP address of PC network card have to be set as follows: (TCP/IPv4 network card settings)

IP address: 192.18.254.254
 Subnet mask: 255.255.0.0

The control unit without configuration (in the factory state) operates in the IP address range 192.18.x.x. When the system configuration file is uploaded, the IP address range will change to 10.10.x.x.

In order to be able to establish a connection to an operational control unit, an additional IP range must be added via the advanced settings of the network card:

IP address: 10.10.254.254
 Subnet mask: 255.255.0.0

Then, with both IP ranges active, a stable network connection can be established with the SMART-CU8-LCD.

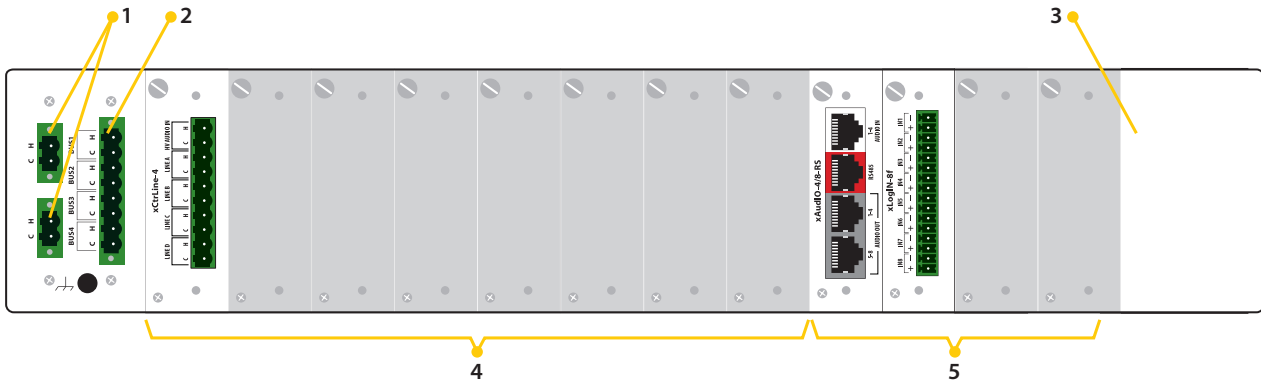

Drawing 2. SMART-CU-8LCD rear panel

1. **Power supply, two identical connectors,**
2. **100 V amplifier output connector to supply internal BUS available for all control cards,**
3. **Communication card slot, 1 item,**
4. **Control card slot, 8 items,**
5. **Function card slot, 4 items.**

7.1.1.2 SMART-CU-11LT unit

The SMART-CU-11LT control unit is designed for the implementation of smaller VAS systems or as an expansion unit in extended systems. In the event of loss of connection to the rest of the system, it is able to carry out fire action scenarios independently, thanks to its locally saved configuration. Plugged into the system's main communication ring, it is able to control amplifiers as well as receive alarm and digital signals and send them to other devices in the system.

SMART-CU-11LT unit:

- » divides the audio signals into individual zones and monitors the correct functioning of the particular zones,
- » checks the status of the loudspeaker lines and amplifiers,
- » detects and signals faults,
- » activates back-up amplifier,
- » is equipped with a dedicated communication card (ABT-xCPU-Audio-4/12), which provides 4 audio inputs and 12 audio outputs for the amplifiers connection; see diagram below,
- » can be an independent device.

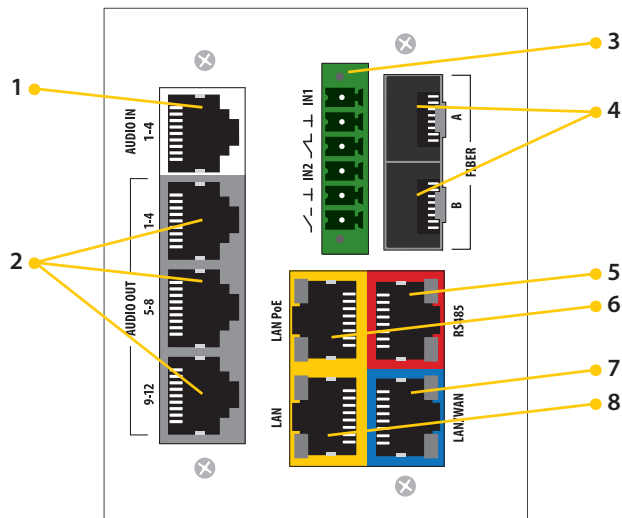

SMART-CU-11LT dedicated communication and audio card diagram

6. **Audio inputs**
7. **Audio outputs**
8. **Logical inputs/outputs**
9. **Fibre optic connectors**
10. **RS485 communication port**
11. **LAN PoE port**
12. **LAN/WAN port**
13. **LAN port**

Table 2. SMART-CU-11LT technical data

Model	SMART-CU-11LT
Power supply	48 V DC (operating range 40-57 V DC), connector with M2.5 screw terminals, distance between partitions 5.08 mm
Power consumption	Up to 100 W (depends on configuration)
Number of slots for control cards	11
Number of slots for function cards	0
Messages	SDHC cards up to 32 GB supported; SDHC SLC 512 MB cards included which provide 20 minutes of messages
Display	none
DSP	8-band equalizer, limiter and delay line on each audio output of the control unit, 3-band equalizer on each audio input of the control unit
Audio inputs	4
Audio input type	balanced

Audio inputs connector	1 × RJ45
Input frequency response	40 Hz... 20 kHz (@1dB) / 400 Hz... 8 kHz (@0,1dB)
Input impedance	≥ 10 kΩ
Maximum input voltage	3 VRMS
Number of audio outputs	12
Audio outputs type	balanced
Audio outputs connectors	3 × RJ45
Output frequency response	40 Hz... 20 kHz (@1dB) / 400 Hz... 8 kHz (@0,1dB)
Harmonic distortion (THD+IMD)	≤ 0,05%
Headroom	10 dB
Signal to Noise Ratio	≥ 90 dB
Channel separation	≥ 80 dB
Output impedance	600 Ω
Rated output level	1 VRMS
Data communication	<p>long-distance communication between devices:</p> <ul style="list-style-type: none"> › 1000BASE-X over fibre › 2 ports for redundant connection <p>communication between devices installed next to each other:</p> <ul style="list-style-type: none"> › 1000BASE-TX / RJ45 over CAT5E cables - 2 ports available on the rear panel of the unit › 100BASE-TX / RJ45 over CAT5 cables - 1 port available on rear panel for external network connection (see notes)
Fiber module – connector type	SFC type modules, SC/LC type connector, multimode or single-mode optical fibre, E30 or E90, OM1 or OM2
Communication with PC	PC (commissioning software); RJ45 connector, twisted pair connections in TIA/EIA-568-B standard via Ethernet protocol
Operating temperature	0°C / +60°C
Operating humidity	15% to 80% (non-condensing)
Storage temperature	-20°C / +70°C
Storage humidity	15% to 80% (non-condensing)
Enclosure finish	case material: steel; front panel made of black painted metal plate
Dimensions	482 (W) × 85 (H) × 325 (D) mm
Installation	19" rack cabinet
Weight	up to 8.4 kg depending on configuration
Accessories	2 brackets and 4 rack-mounting screws, 8 blanking plugs, 100 V power and BUS connector



Drawing 3. SMART-CU-11LT front panel

1. Indicators

- a. Power supply indicator (green LED)
- b. Fault indicator (yellow LED)
- c. Alarm mode indicator (red LED)

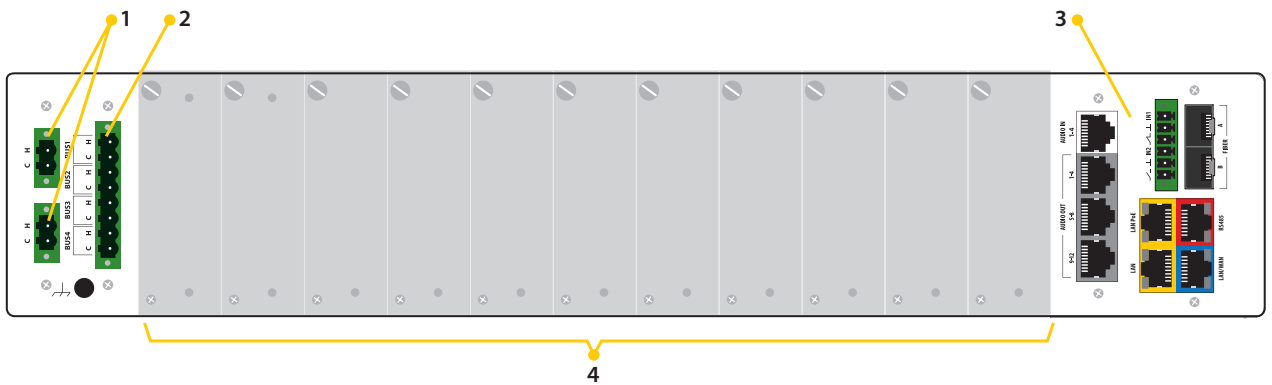

Drawing 4. SMART-CU-11LT rear panel

1. **Power supply, two identical connectors,**
2. **100 V amplifier output connector** to supply internal BUS available for all control cards,
3. **Built-in communication card and audio card**
4. **Control card slots, 11 items.**

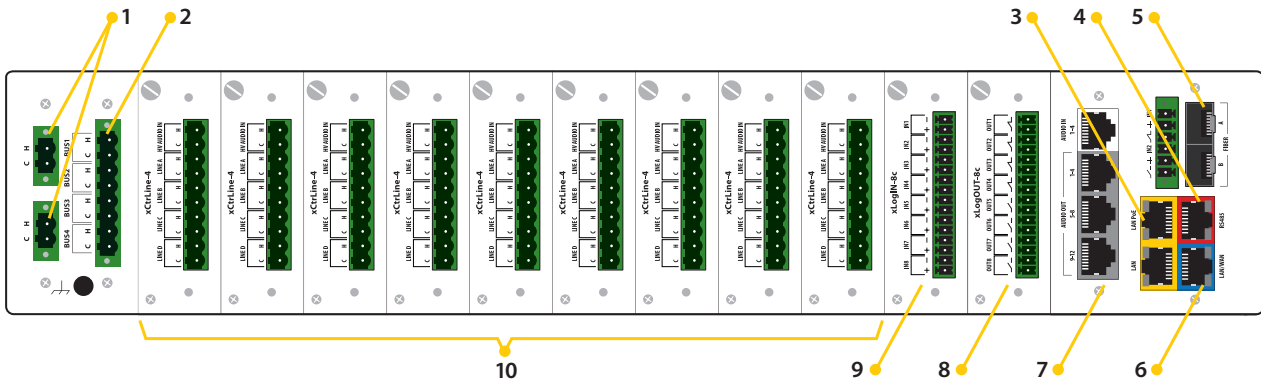

Drawing 5. SMART-CU-11LT rear panel – example layout of extension cards

1. **48 V DC power supply,**
2. **100 V amplifier output connector** to supply internal BUS available for all control cards,
3. **LAN and LAN PoE ports,**
4. **RS485 port,**
5. **Fibre optic connectors, A and B,**
 ▲ Fibre optic connectors are laser-equipped devices. Special care should be taken and visual contact with the laser beam should be avoided.
6. **LAN/WAN port,**
7. **ABT-xCPU-Audio-4/12 card;** white colour indicates 4 audio input channels (top port) and grey colour (3 bottom ports) indicates 12 audio outputs,
8. **ABT-xLogOUT-8c** logical output card,
9. **ABT-xLogIN-8c** logical input card,
10. **ABT-xCtrLine-4** speaker line control cards.

7.1.1.3 SMART-CU-11LCD unit

The SMART-CU-11LCD control unit combines the functions of audio input/output, matrix, DSP, speaker line controller and network switch in a single unit. In the event of loss of connection to the rest of the system, it is able to carry out fire action scenarios independently, thanks to its locally saved configuration. Plugged into the system's main communication ring, it is able to control amplifiers as well as receive alarm and digital signals and send them to other devices in the system. Compared to the SMART-CU-11LT control unit, this unit features a 4.5" LCD colour touchscreen display that provides direct access to the management and monitoring functions of the entire system.

SMART-CU-11LCD unit:

- » divides the audio signals into individual zones and monitors the correct functioning of the particular zones,
- » checks the status of the loudspeaker lines and amplifiers,
- » detects and signals faults,
- » activates back-up amplifier,
- » is equipped with a dedicated communication card (ABT-xCPU-Audio-4/12), which provides 4 audio inputs and 12 audio outputs for the amplifiers connection; see diagram below,
- » can be an independent device.

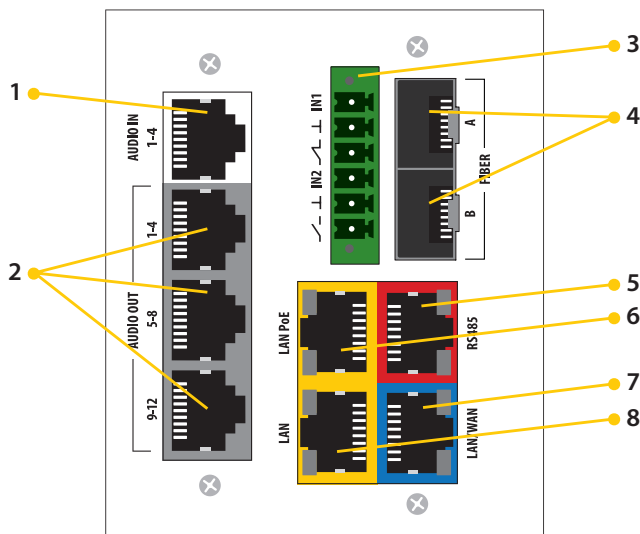

Drawing 6. SMART-CU-11LCD dedicated communication and audio card diagram

1. **Audio inputs**
2. **Audio outputs**
3. **Logical inputs/outputs**
4. **Fibre optic connectors**
5. **RS485 communication port**
6. **LAN PoE port**
7. **LAN/WAN port**
8. **LAN port**

Table 3. SMART-CU-11LCD technical data

Model	SMART-CU-11LCD
Power supply	48 V DC (operating range 40-57 V DC), connector with M2.5 screw terminals, distance between partitions 5.08 mm
Power consumption	Up to 100 W (depends on configuration)
Number of slots for control cards	11
Number of slots for function cards	0
Messages	SDHC cards up to 32 GB supported; SDHC SLC 512 MB cards included which provide 20 minutes of messages
Display	4.5" LCD colour touch screen
DSP	8-band equalizer, limiter and delay line on each audio output of the control unit, 3-band equalizer on each audio input of the control unit
Audio inputs	4
Audio input type	balanced
Audio inputs connector	1 × RJ45
Input frequency response	40 Hz... 20 kHz (@1dB) / 400 Hz... 8 kHz (@0,1dB)
Input impedance	≥ 10 kΩ
Maximum input voltage	3 VRMS
Number of audio outputs	12
Audio outputs type	balanced
Audio outputs connectors	3 × RJ45
Output frequency response	40 Hz... 20 kHz (@1dB) / 400 Hz... 8 kHz (@0,1dB)
Harmonic distortion (THD+IMD)	≤ 0,05%
Headroom	10 dB
Signal to Noise Ratio	≥ 90 dB
Channel separation	≥ 80 dB
Output impedance	600 Ω
Rated output level	1 VRMS
Data communication	<p>long-distance communication between devices:</p> <ul style="list-style-type: none"> › 1000BASE-X over fibre › 2 ports for redundant connection <p>communication between devices installed next to each other:</p> <ul style="list-style-type: none"> › 1000BASE-TX / RJ45 over CAT5E cables - 2 ports available on the rear panel of the unit › 100BASE-TX / RJ45 over CAT5 cables - 1 port available on rear panel for external network connection (see notes)

Fiber module – connector type	SFC type modules, SC/LC type connector, multimode or single-mode optical fibre, E30 or E90, OM1 or OM2
Communication with PC	PC (commissioning software); RJ45 connector, twisted pair connections in TIA/EIA-568-B standard via Ethernet protocol
Operating temperature	0°C / +60°C
Operating humidity	15% to 80% (non-condensing)
Storage temperature	-20°C / +70°C
Storage humidity	15% to 80% (non-condensing)
Enclosure finish	case material: steel; front panel made of black painted metal plate
Dimensions	482 (W) × 85 (H) × 325 (D) mm
Installation	19" rack cabinet
Weight	up to 8.4 kg depending on configuration
Accessories	2 brackets and 4 rack-mounting screws, 8 blanking plugs, 100 V power and BUS connector

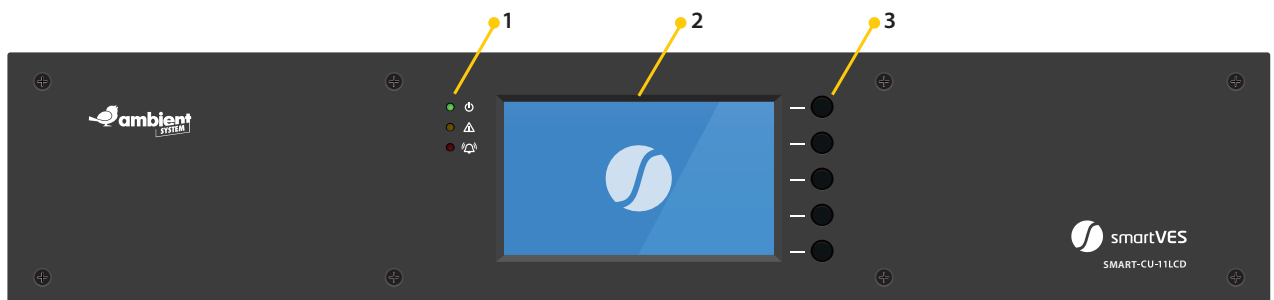

Drawing 7. SMART-CU-11LCD front panel

1. **Indicators**
 - a. Power supply indicator (green LED)
 - b. Fault indicator (yellow LED)
 - c. Alarm mode indicator (red LED)
2. **Display - shows the control unit menu**
3. **Function buttons for navigating the device menu:**
 - a. HOME - press to return to the main menu,
 - b. ENTER – press to select item in the menu,
 - c. ↑ - up arrow – press to navigate in control unit menu,
 - d. ↓ - down arrow – press to navigate in control unit menu,
 - e. BACK – press to return to previous item in the control unit menu.

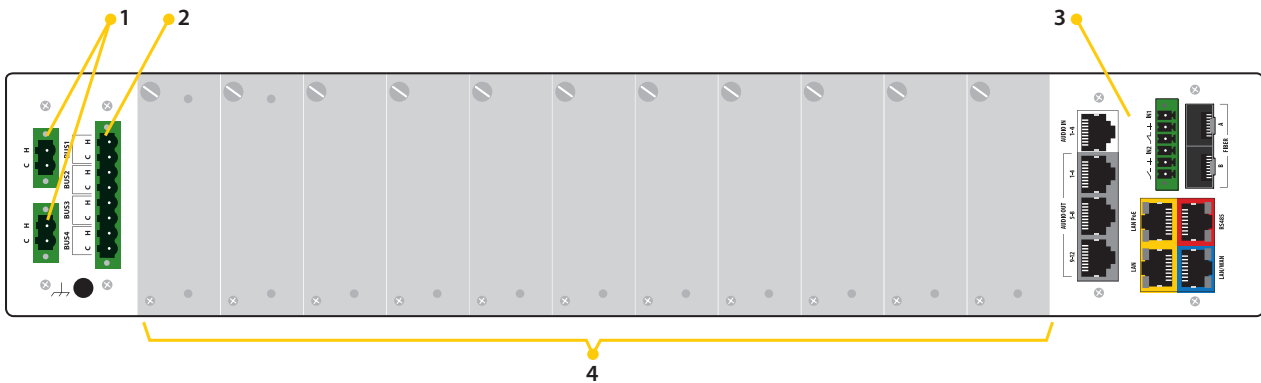

Drawing 8. SMART-CU-11LCD rear panel

1. **Power supply**, two identical connectors,
2. **100 V amplifier output connector** to supply internal BUS available for all control cards,
3. **Built-in communication card and audio card**,
4. **Control card slots**, 11 items.

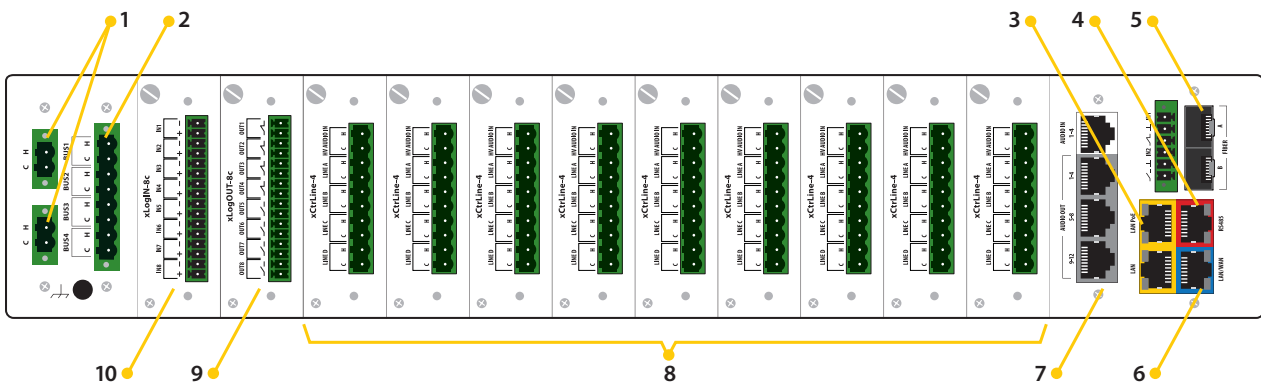

Drawing 9. SMART-CU-11LCD - example layout of extension cards

1. **48 V DC power supply**,
2. **100 V amplifier output connector** to supply internal BUS available for all control cards,
3. **LAN and LAN PoE ports**,
4. **RS485 port**,
5. **Fibre optic connectors**, A and B,
 ▲ Fibre optic connectors are laser-equipped devices. Special care should be taken and visual contact with the laser beam should be avoided.
6. **LAN/WAN port**,
7. **ABT-xCPU-Audio-4/12 card**; white colour indicates 4 audio input channels (top port) and grey colour (3 bottom ports) indicates 12 audio outputs,
8. **ABT-xLogOUT-8c** logical output card,
9. **ABT-xLogIN-8c** logical input card,
10. **ABT-xCtrLine-4** speaker line control cards.
 ▲ The SMART-CU-11LT control unit has an integrated communication card, and an audio input/output card.

7.1.2 Central processing unit SMART-DU1604

The SMART-DU1604 central processing unit is an advanced dynamic digital audio processing unit designed to maximise the speech intelligibility parameter.

A number of algorithms implemented in this unit allow real-time testing of parameters such as:

- » Signal-to-noise ratio (SNR)
- » Speech intelligibility index (STI)
- » Reverberation time (RT)

The measured values of the above parameters allow dynamic correction of the audio signal for 16 independent streams (zones) + 4 independent streams from the system microphones to achieve the highest possible speech intelligibility in the acoustic zones.

SMART-DU-1604 central processing unit

- » monitors acoustic parameters in the zones,
- » corrects the emitted audio signals in the system, aiming for the highest speech intelligibility,
- » has implemented self-calibration algorithm,
- » performs high-quality audio processing with 48kHz sampling and 32-bit resolution,
- » is equipped with a dedicated communication card (xNET).



Drawing 10. SMART-DU-1604 front panel

1. Indicators

- a. Power supply indicator (green LED)
- b. Fault indicator (yellow LED)
- c. Alarm mode indicator (red LED)

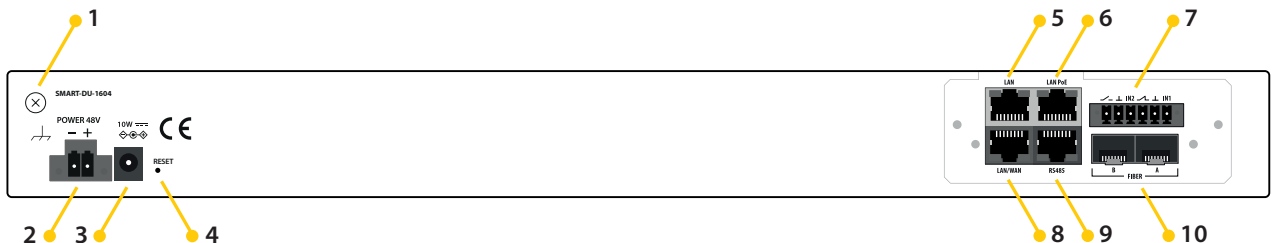

Drawing 11. SMART-DU-1604 rear panel

1. **Screw earthing terminal**
2. **48V power supply connector**
3. **Alternative 48V power supply connector**

4. **Reset (not active)**
5. **LAN port**
6. **LAN PoE port**
7. **Logical inputs/outputs**
8. **LAN/WAN port**
9. **RS485 communication port (not active)**
10. **Fibre optic connectors**

Model	SMART-DU1604 technical data.
Power supply	48 V DC (operating range 40-57 V DC), connector with M2.5 screw terminals, distance between partitions 5.08 mm
Power consumption	Up to 17 W
Number of digital audio inputs	20
Sampling frequency	48kHz
Audio resolution	32 bit
Audio format	PCM
Number of digital audio outputs	20
Communication card	<p>Long-distance communication between devices:</p> <ul style="list-style-type: none"> › 1000BASE-X over fibre, › 2 ports to ensure redundant connection. <p>Communication between devices installed next to each other:</p> <ul style="list-style-type: none"> › 1000BASE-TX / RJ45 over CAT5E cables - 2 ports available on the rear panel of the device, › 100BASE-TX / RJ45 over CAT5 cables - 1 port available on the rear panel for connection to an external network, connection to configuration software.
Fibre optic module - type of connector / type of fibre optic cable	SFP type modules / SC/LC type connectors Multimode or single-mode fibre E 30 or E 90, OM or OM2
Communication with the PC	PC (commissioning software): RJ45 connector, twisted pair connections in TIA / EIA568A standard via Ethernet protocol
Finishing	Housing material: steel / Front panel made of metal plate painted black
Dimensions	482 (W) × 44 (H) × 325 (D) mm
Mounting	19" rack-mounted teletechnical cabinet
Weight	4,3 kg
Accessories	2x power connector 1x connector for inputs, logic outputs
Ambient temperature during operation	-5°C / +40°C
Ambient humidity during operation	15% to 80% (without condensation)
Storage temperature	-20°C / +70°C
Ambient humidity during storage	15% do 80% (without condensation)
IP degree of protection	20
Device compatibility	SMART-ANSM-01, SMART-AMAP-6, SMARTVES

7.1.3 SMART-AMAP-6 Microphone Hub

The SMART-AMAP-6 is an interface for connecting up to six SMART-ANSM-01 measurement microphones to the system and converting their signals into digital form.

These signals are passed on to the SMART-DU1604 units, where they directly shape further digital audio correction. The SMART-AMAP-6 is a network device that can be powered either by PoE or by an external 35-48 V DC power supply. The electronics module is protected by an IP66-rated metal housing, equipped with four sealed cable entries.

SMART-AMAP-6 measurement microphone hub:

- » is compatible with the smartVES devices network,
- » up to 6 hubs in the network,
- » allows monitoring of the connected microphones,
- » supports up to 6 SMART-ANSM-01 microphones.

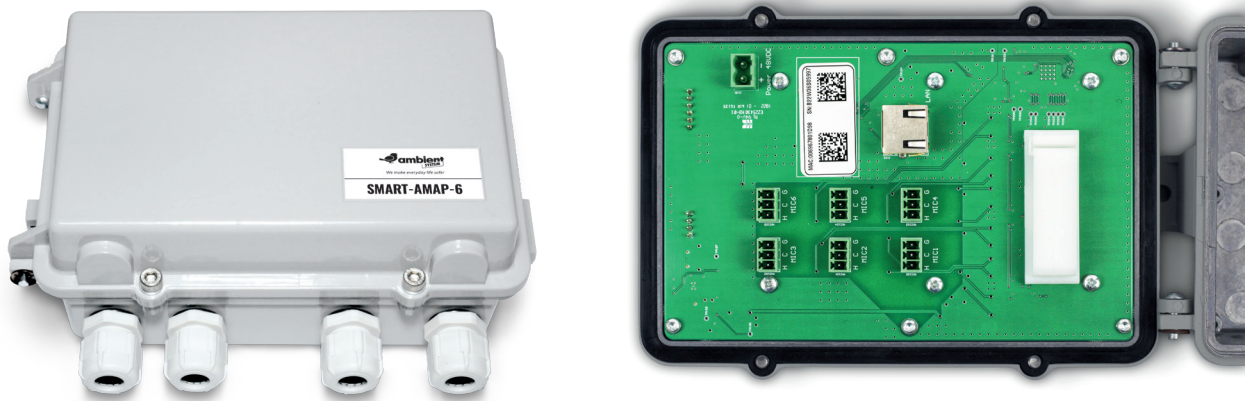

Drawing 12. Housing and interior of the SMART-AMAP-6 measurement microphone hub

Model	SMART-AMAP-6 measurement microphone hub
Power source	PoE (RJ45), or via 2-pin connector
Number of audio inputs	6 differential channels
Power consumption (typical/maximum)	4.5 W / 7 W
Supply voltage range	34V - 58VDC
Sampling frequency	48 kHz
Measuring bandwidth	200 Hz - 9 kHz @3 dB
Differential input impedance	4000 Ω @1kHz
Range of measured values (for corresponding input voltages)	56 dB SPL (1.5mVRMS) - 120 dB SPL (3VRMS)
Phantom power supply	30 VDC
Dimensions	200 x 125 x 90 mm

Weight	1.2 kg
Colour	white
Housing material	Aluminium
Connectors	<ul style="list-style-type: none"> › 6x 3-pin connector type 15EDGVC-3.5 › 1x RJ45 › 1x Phoenix MSTBVA 2-pin screw - 5.08 mm raster
Operating temperature range	-5°C to + 60°C
Ambient humidity	5% to 95% non-condensing
IP degree of protection	54 // 66 - with additional gland sealing
Device compatibility	SMART-ANSM-01, SMART-DU1604
LAN cable types used	Category 5e F/UTP twisted pair, up to 100 m between control unit / switch and SMART-AMAP-6
SMART-ANSM-01 microphone inputs	2-core microphone cable 2x0.22mm ² with spiral copper shield, max. conductor resistance: 86 Ohm/km - connection up to 300 metres or 3x16AWG, unshielded up to 400 metres

7.1.4 SMART-ANSM-01 measurement microphone

The SMART-ANSM-01 measurement microphone is an acoustic sensor with an actuator made using MEMS technology, which allows high repeatability in the production process. It allows the acoustics in a given zone to be measured and the acoustic conditions to be monitored in real time.

The microphone is fitted with a 3 metre cable as standard, but with the appropriate type of cable (see table below), operation at a distance of up to 400 metres from the SMART-AMAP-01 microphone hub is possible. The connection of all components of the smartVES system is illustrated in the graphic further in the service manual.

SMART-ANSM-01 measurement microphone:

- » has a compact size,
- » has a wide dynamic measurement range,
- » has high weather resistance.

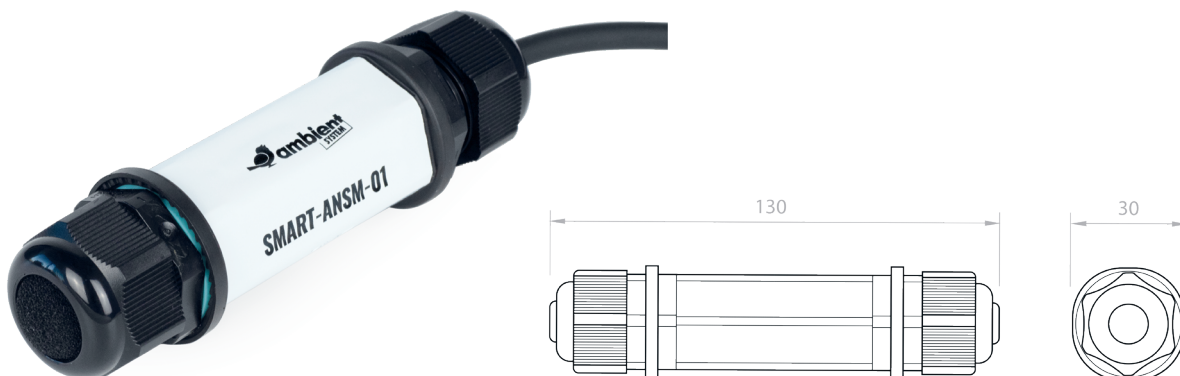

Drawing 13. SMART-ANSM-01 measurement microphone

Model	Mikrofon pomiarowy SMART-ANSM-01
Frequency response	100Hz - 10kHz (+/- 3dB)
Ambient noise measurement range	50 – 120 dB SPL
Output dynamic range	0,7 (50dB) – 3650mV (123 dB)
Directional characteristic	omnidirectional
Power supply	32VDC / 5mA
Signal-to-noise ratio (S/N)	60dB
Output	analogue, balanced
Dimensions	Ø 34.0 × 130.0 mm
Weight	187 grams
Colour	black
Housing material	PA66 GF UL94 V0 / Halogen-free
Connector	3-pin screw connector
Cable	3 metres 2x0.22mm ² PVC with screen
Temperature	-40 °C to +55 °C
Ambient humidity	5% to 95% non-condensing
Degree of protection of the enclosure	IP65
Compatibility	SMART-AMAP-6

7.1.5 Extension cards

Each individual system component has a set of functions related to audio transmission, system operation (handling or event reporting) and self-diagnosis.

7.1.5.1 ABT-xCPU – processor card

The ABT-xCPU processor card is responsible for playing audio messages from the SD card and making them available locally or globally. The processor card performs system and control functions. SMART-CU-8LCD control units are equipped with 1 ABT-xCPU processor card, which allows 8 messages to be played back simultaneously. The ABT-xCPU supports SD cards up to 32 GB on which individual messages are stored, as well as event and fault logs or system update files.



Drawing 14. ABT-xCPU processor card

Processor card:

- » has a SDHC memory slot supporting up to 32 GB,
- » keeps configuration of other units and system elements,
- » has its own group of alarm messages,
- » records events and defects,
- » offers the possibility to upgrade the system,
- » has a micro USB B 2.0 port.

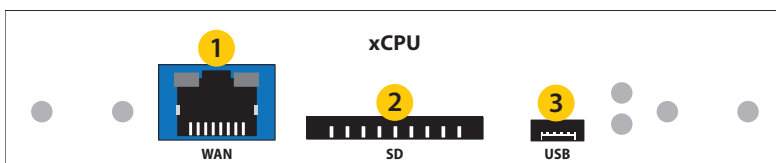

Drawing 15. ABT-xCPU processor card

1. 100 Mbps LAN/WAN port for connecting a PC with configuration software (from firmware version 0.750.1 onwards, communication via LAN/WAN port is via an encrypted protocol),
2. SDHC memory card slot (max 32GB),
3. Micro USB 2.0 port (not supported in version 1.0.0).

Table 4. ABT-xCPU technical data

Model	ABT-xCPU
Power supply	SMART-CU-8LCD control unit backplane
Power consumption	+5 V, typically 270 mA, max. approx. 900 mA
Sockets	RJ45; SDHC up to 32 GB, class 10; micro USB 2.0
Maximum number of messages played simultaneously	8
Maximum number of shared LAN channels	8
Maximum number of received LAN channels	8

Operating temperature	0°C / +60°C
Operating humidity	15% to 80% (non-condensing)
Storage temperature	-20°C / +70°C
Storage humidity	5% to 95% (non-condensing)

7.1.5.2 ABT-xNET-1Gb/WAN/RS – communication card

The ABT-xNET-1Gb/WAN/RS is a communication card consisting of two independent 1Gbit network switches. The CU-11LT/LCD units are equipped with this type of communication card as standard, while for the SMART-CU-8LCD it is an optional accessory if a redundant fibre connection is required. Network switch 1 is exclusively intended for data transmission related to the basic functionality of the smartVES system, i.e. implementation of voice alarm system tasks and AVB operation. Network switch 2 is intended for remote connections. The card supports TCP/UDP/PTP/DHCP protocols and provides audio data exchange in CPU-OFF mode via an innovative protocol developed by Ambient System. An additional functional advantage of the card is that it supports PoE technology to power, for example, a firefighter's microphone.



Drawing 16. ABT-xNET-1Gb/WAN/RS communication card

ABT-xNET-1Gb/WAN/RS communication card:

- » has two switches (2 LAN ports 10/100/1000): a system one (for VAS communication) and one for remote connections (1 LAN/WAN port 10/100 - configurable operating mode; from firmware version 0.750.1 onwards, communication via the LAN/WAN port is done using an encrypted protocol),
- » is equipped with an AVB-capable switch,
- » allows 1Gbps transmission rate and also has a fibre interface (2 connectors for SFP modules),
- » supports TCP/UDP/PTP/DHCP protocols,
- » dynamically assigns IP addresses,
- » has an active PoE option,
- » has the ability to handle two parametric inputs and two relay outputs (each channel independently configurable), and supports NC/NO relay outputs,
- » in CPU-OFF mode. transmits audio data using an independent protocol,

» allow future use of the network infrastructure for other audio visual purposes.

Highly reliable 1.25 Gbps SFP optical modules are required to connect communication cards and firefighter microphones via optical cable.

SFP modules work with single or multimode optical fibres, transmitting information at speeds of up to 1.25 Gbps. They transmit data over a single or pair of optical fibres, depending on the SFP module used. Both LC and SC type connectors can be used. An additional functionality is the possibility to carry out digital diagnostics if the module is equipped with DDM (Digital Diagnostics Monitoring).

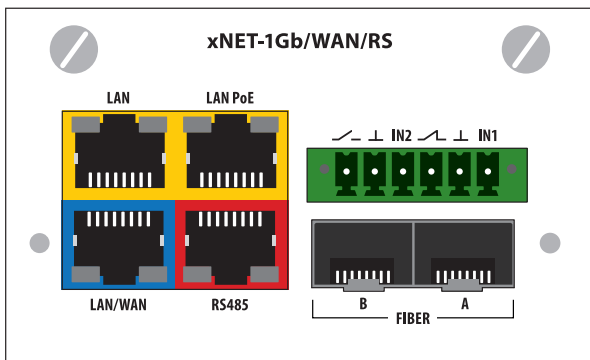

Drawing 17. ABT-xNET-1Gb/WAN/RS communication card

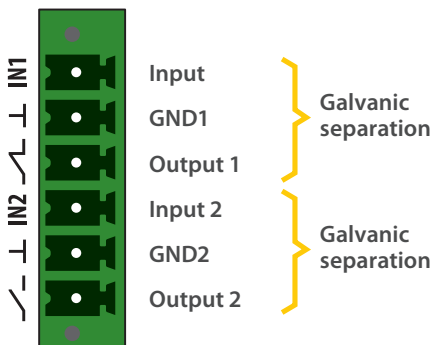

Drawing 18. Logical inputs/outputs diagram

Table 5. ABT-xNET-1Gb/WAN/RS technical data

Model	ABT-xNET-1Gb/WAN/RS
Power supply	SMART-CU control unit backplane
Power consumption	48 V, approx. 100 mA; I/O extension/PoE - maximum consumption 360 mA, typical consumption depends on the devices connected to the card via LAN PoE connector max. 15 W
Fiber module – connector type	SFC type modules, SC/LC type connector, multimode or single-mode optical fibre, E30 or E90, OM1 or OM2

Logical inputs/outputs	2 independent channels; galvanically separated; 1 × NO, 1 × NC output
Maximum switching current	1 A peak *
Maximum switching voltage	50 V AC/DC peak *
Maximum switching power	30 W*
Parametric input signal source	passive, standard resistors: 4 kΩ↔10 kΩ, 0/1/short-circuit detection
Type of logical input/output sockets	PHOENIX type 6-pin screw terminals, 3.5 mm
PoE output voltage, load capacity	48 V, 0,3 A
Number of RS485 connectors	1
Maximum RS485 cable length	1200 m (according to RS485 specifications and characteristics)
Operating temperature	0°C / +60°C
Operating humidity	15% to 80% (non-condensing)
Storage temperature	-20°C / +70°C
Storage humidity	15% to 80% (non-condensing)
Dimensions	70 × 160 × 30 (mm)

- ⚠ WARNING!** Any combination of voltage and current values for DC must not exceed the maximum switching power. Capacitive and inductive loads are not permitted due to the large surge in start-up current/voltage, which may significantly exceed the maximum allowed switching current or voltage.

7.1.5.3 ABT-xLogIN-8f – logical input card for function slot

The logical input card has 8 independently programmable contact-type inputs that allow it to accept external signals to trigger the appropriate response from the smartVES system. The ABT-xLogIN-8f card has two modes of operation: contact, which detects the shorting and opening of a terminal, and monitor mode, which detects the shorting and opening of the cable connecting the card to the switch, in addition to the contact functions. The ABT-xLogIN-8f card can only be used in the SMART-CU-8LCD control unit.

Main card features:

- » reporting hardware errors identified on the card;
- » reporting an incorrect input voltage level (short circuit, open circuit); connector monitoring carried out by measuring the voltage at the parametric resistors; the card detects four states: line short circuit, line open circuit and input closing and opening,
- » calling a scenario, action, matrix by any state of any input,
- » two possible operating modes - NO, and NC.

Good to know:

- » individual logical inputs in the system are not galvanically isolated from the rest of the elements,
- » all logical inputs have common ground.

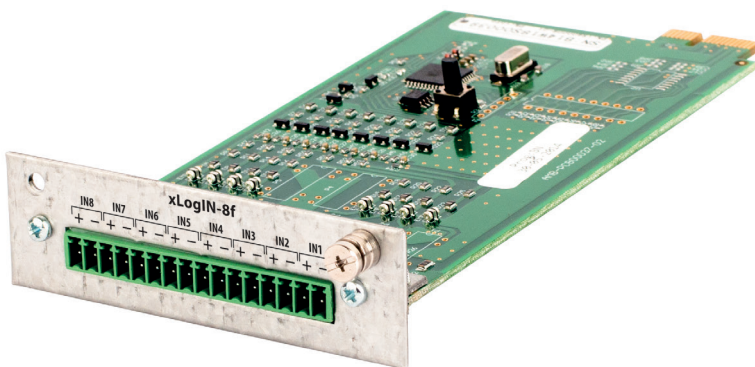

Drawing 19. Logical input card for function slot

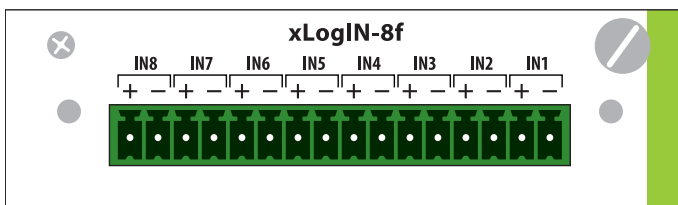

Drawing 20. ABT-xLogIN-8f front panel

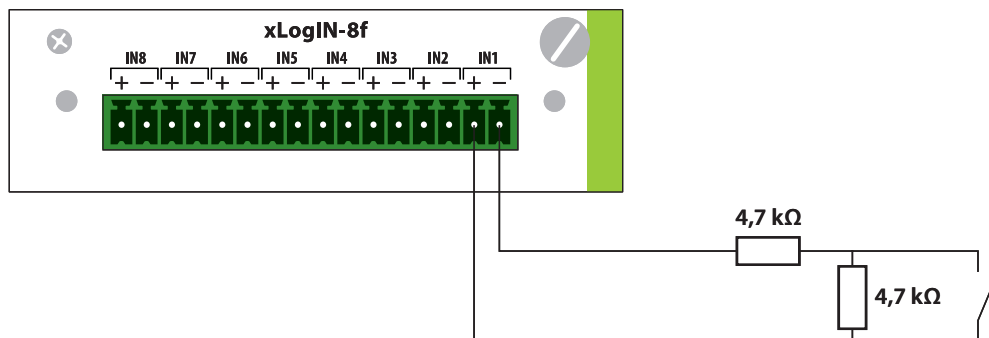

Drawing 21. Resistor wiring example on a monitored line

Table 6. ABT-xLogIN-8f/c technical data

Model	ABT-xLogIN-8f/c
Power supply	internal from control unit
Current consumption	10 mA at 48 V
Logical inputs	8
Supply voltage	12 V
Control inputs type	NO / NC
Resistance value interpreted as the opening of the line	RL > 20k
Resistance value interpreted as a contact close	RL < 5k
Resistance value interpreted as a contact open	RL > 10k
Operating temperature	0°C / +60°C
Operating humidity	15% to 80% (non-condensing)
Storage temperature	-20°C / +70°C
Storage humidity	5% to 95% (non-condensing)
Connector type	16-pin PHOENIX type connector, 3.5mm
Dimensions	ABT-xLogIN-8c – 70 × 215 × 25 (mm) ABT-xLogIN-8f – 70 × 160 × 25 (mm)

7.1.5.4 ABT-xLogIN-8c – logical input card for control slot

The card is functionally identical to the ABT-xLogIN-8f. The only difference is the length of the PCB and the type of connector for the card in the control slots (the card is designed for use in SMART-CU-11LCD and SMART-CU-11LT control units).

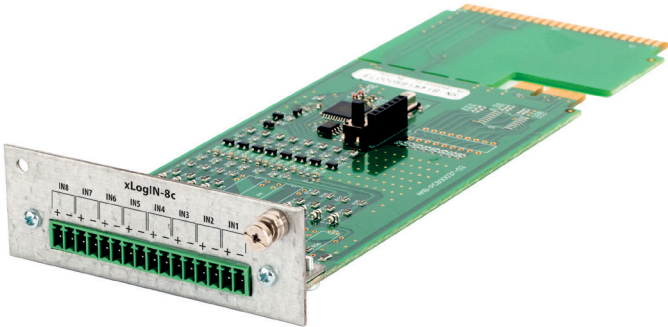

Drawing 22. Logical input card for control slot

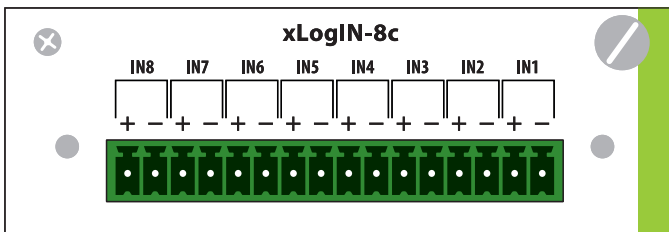

Drawing 23. ABT-xLogIN-8 - front panel

7.1.5.5 ABT-xLogOUT-8f – logical output card for function slot

The relay output card is equipped with 8 fully programmable relays that can signal various smartVES system statuses. Channels 1 to 4 have NC (normally open) relays and channels 5 to 8 have NO (normally open) relays.

Main card features:

- » outputs can operate in two modes: normally open and normally closed,
- » the card is equipped with 4 NO relays and 4 NC relays in case of power failure; for normal operation the type is defined from the configurator,
- » assigning any output to any system event.

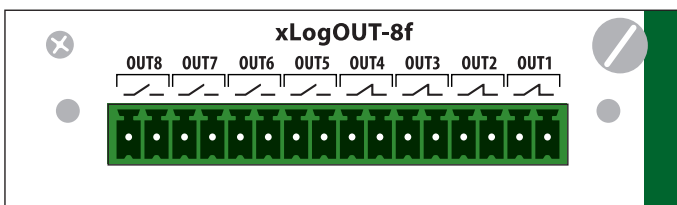

Drawing 24. ABT-xLogOUT-8f front panel

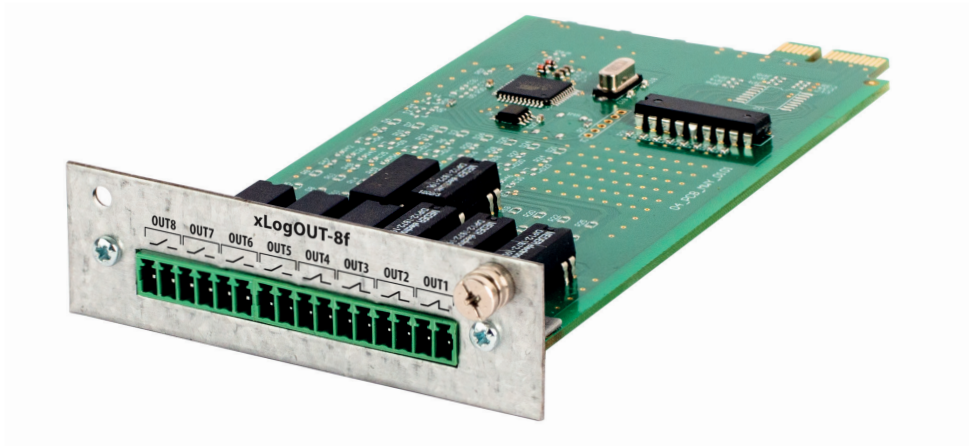

Drawing 25. Logical input card for function slot

Table 7. ABT-xLogOUT-8f/c technical data

Model	ABT-xLogOUT-8f/c
Power supply	internal from control unit
Current consumption	10 mA przy 48 V
Logical outputs	8, galvanically separated
Outputs type	4 NC and 4 NO outputs
Connector type	16-pin PHOENIX type connector, 3.5 mm
Maximum switching current	0,5 A peak*
Maximum switching voltage	48 V AC / DC peak*
Maximum switching power	10 W*
Operating temperature	0°C / +60°C
Operating humidity	15% to 80% (non-condensing)
Storage temperature	-20°C / +70°C
Storage humidity	5% to 95% (non-condensing)
Dimensions	ABT-xLogOUT-8c – 70 × 215 × 25 (mm) ABT-xLogOUT-8f – 70 × 160 × 25 (mm)

⚠ WARNING! Any combination of voltage and current values for DC must not exceed the maximum switching power. Capacitive and inductive loads are not permitted due to the large surge in start-up current/voltage, which may significantly exceed the maximum allowed switching current or voltage.

7.1.5.6 ABT-xLogOUT-8c – logical output card for control slot

The card is functionally identical to the ABT-xLogOUT-8f. The only difference is the length of the PCB and the type of connector for the card in the control slots (the card is designed for use in SMART-CU-11LCD and SMART-CU-11LT control units).

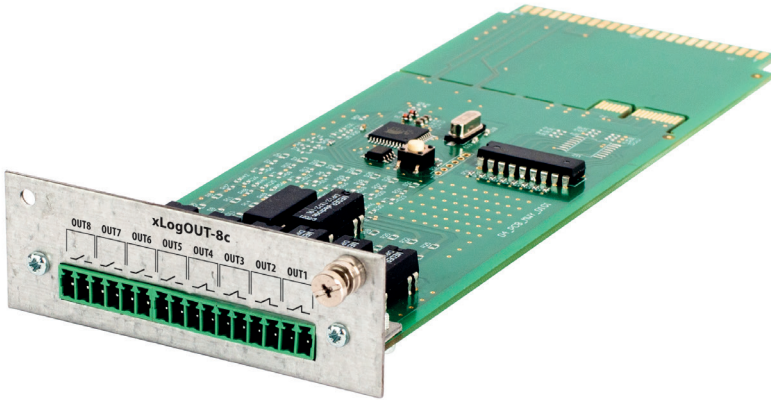

Drawing 26. Logical input card for control slot

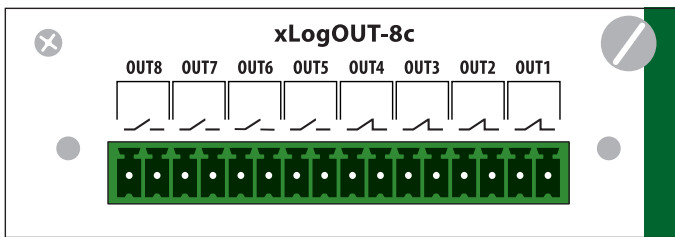

Drawing 27. ABT-xLogOUT-8c front panel

7.1.5.7 ABT-xAudio-4/8-RS – audio input / output card with RS485

4 audio inputs and 8 audio outputs card with RS485 port for functional slot.

The ABT-xAudio-4/8-RS card extends the audio signal processing capabilities of the SMART-CU-8LCD. The card provides support for 4 line audio inputs, 8 symmetrical line outputs and is equipped with an RS485 interface. Each line audio input is equipped with 3 parametric filters and gain control while each line output is equipped with an acoustic feedback suppressor, limiter, delay line (30000 ms buffer available for all 8 outputs), gain control and 8 parametric filters. The basic equipment of the SMART-CU-8LCD control unit includes one card of this type. At most, the unit can have all 4 function slots occupied, allowing up to 16 audio inputs to be supported and up to 32 audio outputs to be transmitted simultaneously (local outputs within the unit) while sending and receiving 8 audio channels over the network between smartVES units.



Drawing 28. ABT-xAudio-4/8-RS card

RS485 connector

Type: RJ45

Connector pin assignment:

Pin	Name	Description
1	GND	Ground
2	GND	Ground
3	BUS1_A	Data bus – line A
4	BUS1_B	Data bus – line B
5	BUS2_A	Data bus – line A
6	BUS2_B	Data bus – line B
7	+48 V	Power supply, max 1 A
8	+48 V	Power supply, max 1 A

Złącze Audio IN 1-4

Type: RJ45

Connector pin assignment:

Pin	Name	Description
1	CH1_IN_H	Audio input – hot
2	CH1_IN_C	Audio input – cold
3	CH2_IN_H	Audio input – hot
4	CH2_IN_C	Audio input – cold
5	CH3_IN_H	Audio input – hot
6	CH3_IN_C	Audio input – cold
7	CH4_IN_H	Audio input – hot
8	CH4_IN_C	Audio input – cold

Audio OUT 1-4 connector

Type: RJ45

Connector pin assignment:

Pin	Name	Description
1	CH1_OUT_H	Audio input – hot
2	CH1_OUT_C	Audio input – cold
3	CH2_OUT_H	Audio input – hot
4	CH2_OUT_C	Audio input – cold
5	CH3_OUT_H	Audio input – hot
6	CH3_OUT_C	Audio input – cold
7	CH4_OUT_H	Audio input – hot
8	CH4_OUT_C	Audio input – cold

Złącze Audio OUT 4-8

Type: RJ45

Connector pin assignment:

Pin	Name	Description
1	CH5_OUT_H	Audio input – hot
2	CH5_OUT_C	Audio input – cold
3	CH6_OUT_H	Audio input – hot
4	CH6_OUT_C	Audio input – cold
5	CH7_OUT_H	Audio input – hot
6	CH7_OUT_C	Audio input – cold
7	CH8_OUT_H	Audio input – hot
8	CH8_OUT_C	Audio input – cold

Table 8. ABT-xAUDIO-4/8-RS technical data

Model	ABT-xAUDIO-4/8-RS
Power supply	SMART-CU-8LCD control unit backplane
Current consumption	100 mA at 48 V
Audio inputs	
Audio inputs	4
Audio input type	balanced
Audio inputs connector	1 × RJ45
Input impedance	≥ 10 kΩ
Maximum input voltage	≤ 3 VRMS
Audio outputs	
Audio outputs	8
Audio output type	symmetrical
Audio outputs connector	2 × RJ45
Frequency response	20 Hz – 20 kHz (@1 dB) 400 Hz – 8kHz (@0,1 dB)
Harmonic distortion (THD+IMD)	≤ 0,05%
Headroom	10 dB
Signal to Noise Ratio	≥ 90 dB
Channel separation	≥ 80 dB
Output impedance	600 Ω
RS485 interface	
Connectors	1 x RJ45
Transmission speed	≥ 19200bps
RS485 connector supply	48 V with 2 A current efficiency
Operating temperature	0°C / +60°C
Operating humidity	15% to 80% (non-condensing)
Storage temperature	-20°C / +70°C
Storage humidity	5% to 95% (non-condensing)
Dimensions	70 × 160 × 25 (mm)

7.1.5.8 ABT-xAudio-8 - 8 audio input card for function slot

The ABT-xAudio-8 card has 8 symmetrical audio inputs (line level) and works with any function slot of the SMART-CU-8LCD unit. Each audio input is equipped with 3 parametric filters and gain control.



Drawing 29. 8 audio input card

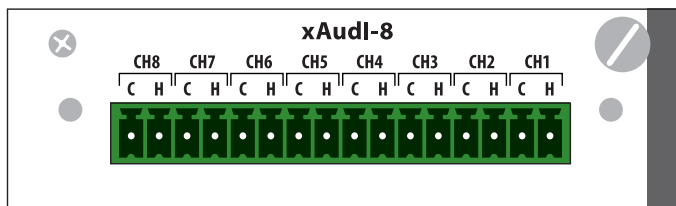

Drawing 30. ABT-xAudio-8 front panel

Table 9. ABT-xAudio-8 technical data

Model	ABT-xAudio-8
Power supply	SMART-CU-8LCD control unit backplane
Current consumption	25 mA at 48 V
Audio inputs	4
Audio input type	balanced
Audio inputs connector	16-pin PHOENIX type connector, 3.5 mm
Input impedance	≥ 10 kΩ
Maximum input voltage	≤ 3 VRMS
Operating temperature	0°C / +60°C
Operating humidity	15% to 80% (non-condensing)
Storage temperature	-20°C / +70°C
Storage humidity	5% to 95% (non-condensing)
Dimensions	70 × 160 × 25 (mm)

7.1.5.9 ABT-xCtrLine-4 – 4 loudspeaker lines control card

The loudspeaker line control card has 4 independent, programmable outputs (A, B, C, D). Each loudspeaker line output is equipped with an independent measurement path. Measurement method, tolerance, reference impedance values and loudspeaker zone assignment are set using the dedicated configuration software. In addition to measuring the impedance of the loudspeaker lines, the card provides short-circuit, open-circuit and ground detection, and follows long-term impedance changes associated with, for example, changes in ambient temperature.

When using the combination of the amplifiers connected to the 100V internal buses it is necessary to use at least one x-CtrLine4 card. This type of card can monitor the presence of both type of amplifiers, connected to the HV Audio IN of the individual card as well as all the amplifiers connected to the buses.

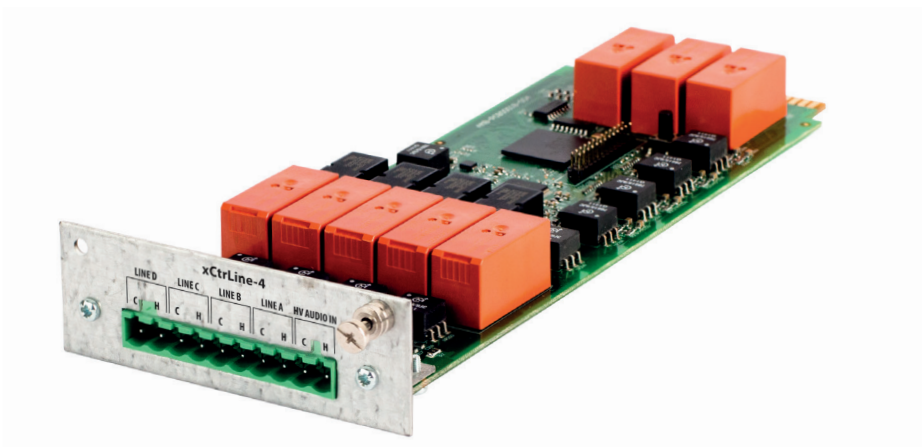

Drawing 31. ABT-xCtrLine-4 loudspeaker lines control card

Line measurement can be performed using different methods:

- » impedance,
- » loop,
- » loop with external short-circuit isolators.

The card provides short-circuit, open-circuit, element absence and earth fault detection.

⚠ The maximum power the ABT-xCtrLine-4 card can handle is 800 W for the 100 V line. The load on a single output of the card can be a maximum of 450 W, bearing in mind the maximum power of 800 W for the whole card. We distribute the lines with a high load in such a way that we do not load two adjacent outputs, e.g.: A=450 W, B=not connected, C=350 W, D=not connected. Monitoring of the loudspeaker lines is carried out in such a way that the audio signal from the loudspeakers is not disturbed.

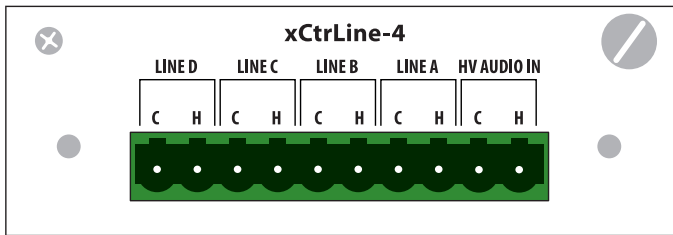

Drawing 32. ABT-xCtrLine-4 front panel

Table 10. ABT-xCtrLine-4 technical data

Model	ABT-xCtrLine-4
Power supply	SMART-CU control unit backplane
Current consumption	152 mA at 48 V
Connector type	10-pin PHOENIX type connector, 5.08 mm
Impedance measurement frequency	1 kHz to 48 kHz
Frequency with EOL modules power supply	18 kHz to 24 kHz
Maximum current measured	20 A
Maximum voltage measured	200 V
Measurement accuracy	up to 5%
Operating temperature	0°C / +60°C
Operating humidity	15% to 80% (non-condensing)
Storage temperature	-20°C / +70°C
Storage humidity	5% to 95% (non-condensing)
Dimensions	70 × 215 × 30 (mm)

7.1.5.10 ABT-xCtrLine-2 – 2 loudspeaker lines control card

The loudspeaker line control card has 2 independent, programmable outputs (A, B). Each loudspeaker line output is equipped with an independent measurement path. Measurement method, tolerance, reference impedance values and loudspeaker zone assignment are set using the dedicated configuration software. In addition to measuring the impedance of the loudspeaker lines, the card provides short-circuit, open-circuit and ground detection, and follows long-term impedance changes associated with, for example, changes in ambient temperature.

⚠ A minimum of one ABT-xCtrLine-4 card is required when connecting amplifiers to the control unit via BUS. The ABT-xCtrLine-2 card cannot simultaneously supervise an amplifier connected to the individual input of the HV Audio IN card as well as all amplifiers connected to the BUSes of the unit.

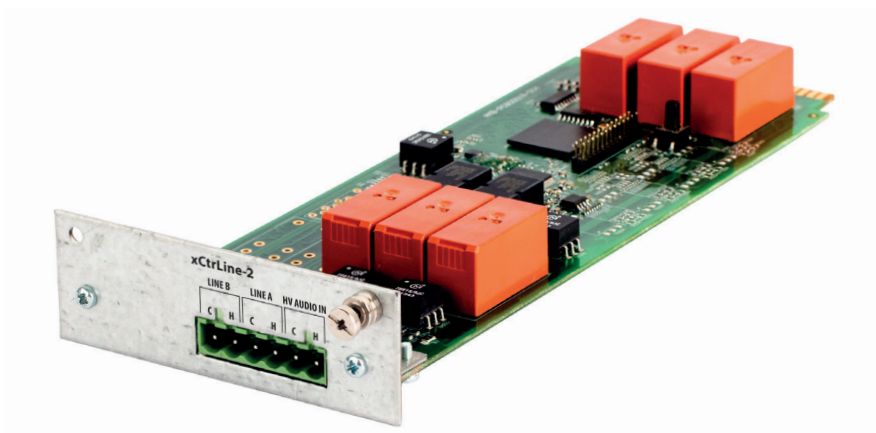

Drawing 33. ABT-xCtrLine-2 loudspeaker lines control card

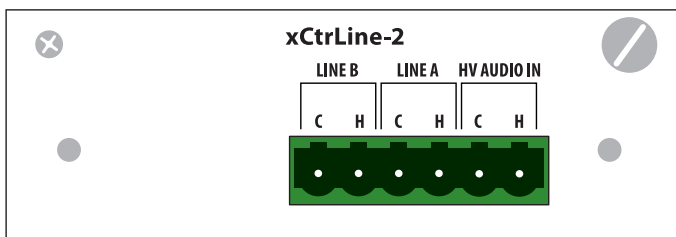

Drawing 34. ABT-xCtrLine-2 front panel

Line measurement can be performed using different methods:

- » impedance,
- » loop,
- » loop with external short-circuit isolators.

The card provides short-circuit, open-circuit, element absence and earth fault detection.

- ⚠** The maximum power that the ABT-xCtrLine-2 card can handle is 600W for the 100V line. The load on a single output of the card can be a maximum of 450W, bearing in mind the maximum power of 600W for the whole card. A line with a high load is distributed in such a way that two adjacent outputs are not loaded with the maximum allowed power, e.g.: A=450W, B=not connected or A=300W, B=300W. Monitoring of the loudspeaker lines is carried out in a way that does not interfere with the audio signal from the loudspeakers.

Table 11. ABT-xCtrLine-2 technical data

Model	ABT-xCtrLine-2
Power supply	SMART-CU control unit backplane
Current consumption	121 mA at 48 V
Connector type	6-pin PHOENIX type connector, 5.08 mm
Impedance measurement frequency	1 kHz to 48 kHz
Frequency with EOL modules power supply	18 kHz to 24 kHz
Maximum current measured	20 A
Maximum voltage measured	200 V
Measurement accuracy	up to 5%
Operating temperature	0°C / +60°C
Operating humidity	15% to 80% (non-condensing)
Storage temperature	-20°C / +70°C
Storage humidity	5% to 95% (non-condensing)
Dimensions	70 × 215 × 30 (mm)

Connecting loudspeaker lines illustrated with an example of xCtrLine-2 card

Loudspeaker lines can be connected using 2 methods: normal (impedance measurement) and loop.

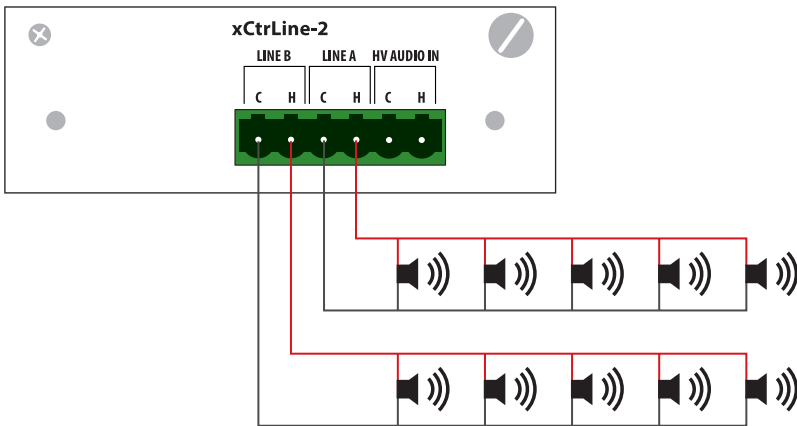

Drawing 35. Normal connection (impedance measurement)

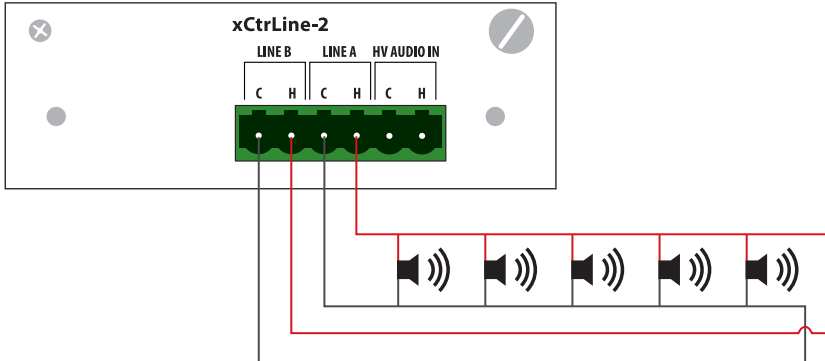

Drawing 36. Loop connection

7.1.5.11 SMART-xCtrlLine-44 - 4 loudspeaker lines control card

The SMART-xCtrlLine-44 card provides 4 independent speaker line outputs (A, B, C, D) with possible routing of 5 signals (4 × 100 V BUS, 1x high voltage individual input). Each line (A, B, C, D) can play a different message at the same time.

The card allows switching between the main and backup amplifier modules.

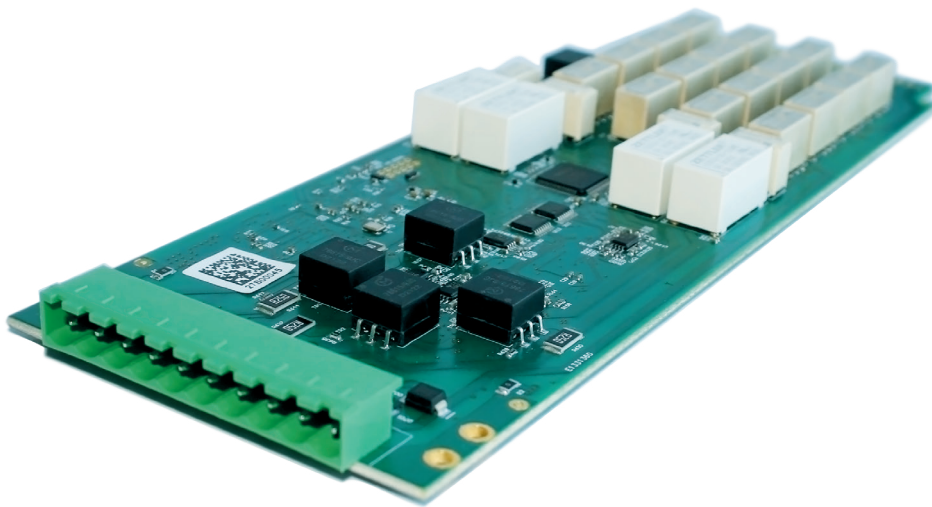

Drawing 37. SMART-xCtrlLine-44 speaker line control card

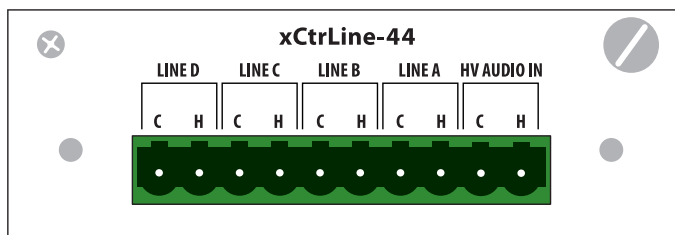

Drawing 38. SMART-xCtrlLine-44 front panel

Line measurement can be performed using different methods:

- » impedance,
- » loop with external short-circuit isolators,
- » EOL modules.

The card provides short-circuit, open-circuit, element absence and earth fault detection.

The maximum power the SMART-xCtrlLine-44 can handle is 800 W for a 100 V line. For loads above 200W on a loudspeaker line, we suggest not reducing the standard tolerance setting of 25%. Reduction may result in false line impedance errors. The maximum permissible load on a loudspeaker line is 300W. For optimum operating conditions of the measurement systems, we recommend that the load difference of the loudspeaker lines should not exceed a ratio of 2:1. The impedance of the loudspeaker lines can be measured at 1kHz in service mode, as well as at 20kHz in standard mode.

Table 12. SMART-xCtrLine-44 technical data

Model	SMART-xCtrLine-44
Power supply	SMART-CU control unit backplane
Current consumption	152 mA at 48 V
Connector type	10-pin PHOENIX type connector, 5.08 mm
Impedance measurement frequency	1 kHz to 48 kHz
Frequency with EOL modules power supply	18 kHz to 24 kHz
Maximum current measured	20 A
Maximum voltage measured	200 V
Measurement accuracy	up to 5%
Operating temperature	-5°C / 40°C
Operating humidity	15% to 80% (non-condensing)
Storage temperature	-20°C / 70°C
Storage humidity	5% to 95% (non-condensing)
Dimensions	70 × 215 × 30 (mm)

7.1.6 Power amplifiers

The SMART-PAxxxx power amplifier is used to amplify and distribute the audio signal supplied by the control unit or an external BGM source. The unit's output channels ensure that the loudspeaker lines are properly driven while maintaining the nominal power of their load.

The amplifier module can be supplied with DC voltage from 40 to 57 VDC (nominally 48 VDC). In the basic system configuration, a dedicated SMART-PSM48 power manager is used as the power source, along with SMART-PS48800 power supplies and a 4 × 12 VRLA battery pack.

Power amplifiers from the SMART-PAxxxx series are designed for installation in a 19" IP30 rack where other system components (e.g. power supplies, control unit) are also mounted. Optionally, it is possible to use the SMART-PAxxxxB amplifier as a stand-alone device without rack mounting.

This manual applies to the operation of the amplifiers that come in three basic models:

- » **SMART-PA8080** – 8 × 80 W audio channels,
- » **SMART-PA8160** – 8 × 160 W audio channels,
- » **SMART-PA2650** – 2 × 650 W audio channels.

Two amplifiers in a half output module number versions:

- » **SMART-PA4160** – 4 × 160 W audio channels,
- » **SMART-PA1650** – 1 × 650 W audio channel.

Only amplifiers with the designation SMART-PAxxxxE have additional local BGM inputs.

Before switching on the amplifier, make sure that the minimum volume level has been set and that the speakers and sound sources are correctly connected.

⚠ CAUTION: The system is activated about 3 seconds after turning the device on. This is the regular operation of the amplifier that results from work of embedded automatic protection of circuits, loudspeakers and other connected components.

7.1.6.1 Front panel

The drawing shows the front panel of the amplifier module with the labels of its most important components.

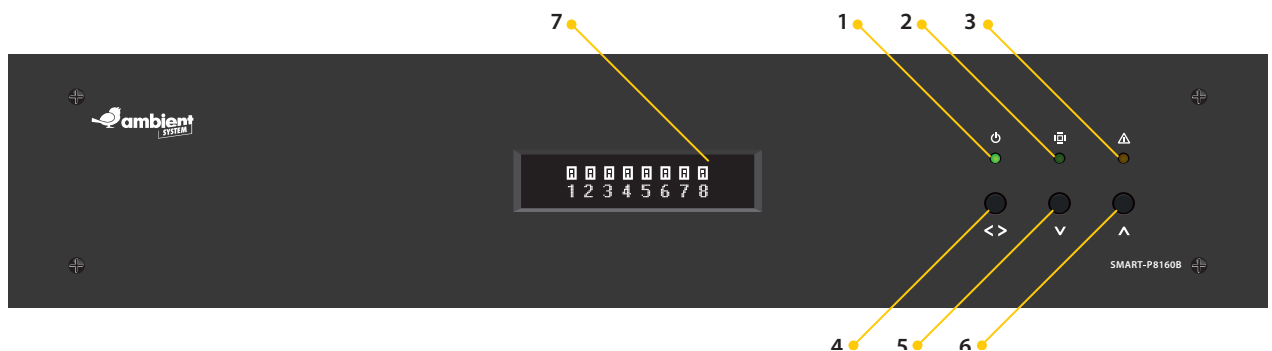

Drawing 39. SMART-PAxxxx front panel

1. **Power** – green LED indicating power supply,
2. **Active** – green LED indicating proper operation,
3. **Fault** – yellow LED indicating amplifier failure,
4. **Enter/exit** – amplifier menu operation button,
5. **Down arrow** – amplifier menu navigation button,
6. **Up arrow** – amplifier menu navigation button,
7. **Display** – display showing the amplifier's menu.

7.1.6.2 Front panel operation

The drawings below show a section of the front panel containing the buttons and LEDs indicating the module's status and a diagram of the amplifier's menu structure in the form of the information available on the alphanumeric display.

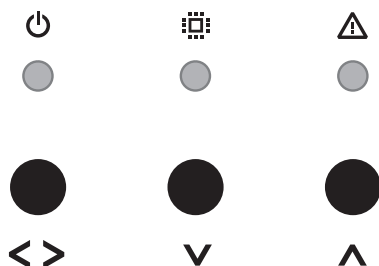

Drawing 40. Front panel buttons

The front panel buttons are used to control the amplifier using the menu. The menu allows you to view the status (active / inactive / overheated / fuse blown), edit the output signal level of any amplifier channel and change the number of active amplifier modules. How to navigate the menu using the buttons is described below the figure. The default password is: „1992”.

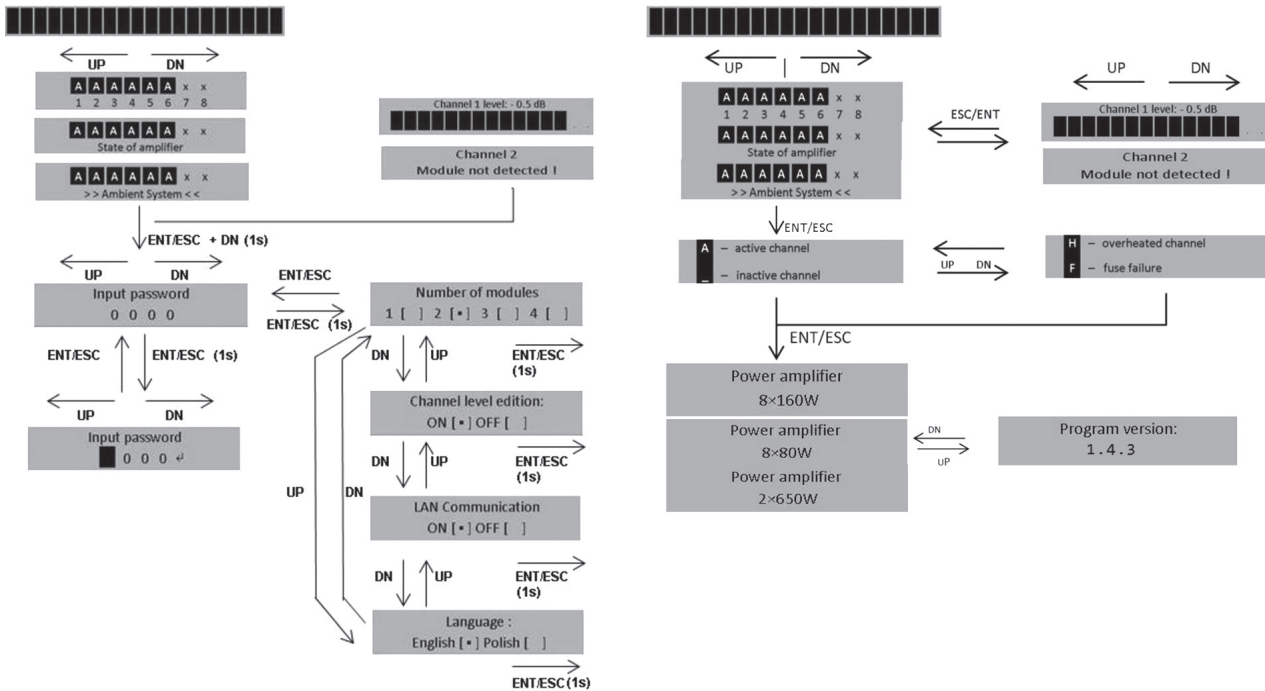

Drawing 41. Block diagram of the menu structure of the amplifier

ENTER – press <> button and hold for 1 s,

EXIT – press <> button,

VOLUME CHANGE – use the arrows to select the desired amplifier channel, press the „ENTER” button, use the arrows to set the desired attenuation level, confirm with the „EXIT” button”,

ENTERING SERVICE MODE – press the <> button and the down arrow button simultaneously and hold for approx. 1 s. In the service mode it is possible to edit the channel attenuation and optionally activate LAN communication. The settings are changed by selecting the option with the arrow keys, entering the edit mode („ENTER” button), changing the option and confirming („ENTER” button). Pressing the <> button from the top menu level results in the display of a legend containing a description of the symbols appearing on the display. Pressing the <> button twice allows you to return to the main menu displaying the status of the amplifier.

7.1.6.3 Rear panel

The drawing below shows the design of the rear panel, together with the labels of the connectors used.

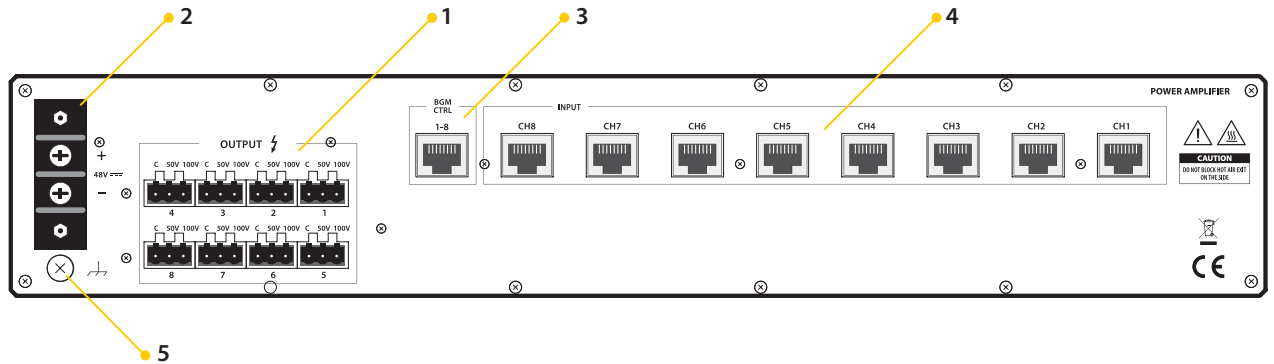

Drawing 42. SMART-PAxxxx rear panel

1. **Amplifier output connectors**

The amplifier output connectors are used to supply power to the speaker lines connected to the control unit. It is essential to ensure that the connected speaker lines have an impedance equal to or higher than the minimum permissible for the amplifier. The channel output numbers are indicated by the numbers 1 to 8 (or 1 to 2 for the SMART-PA2650).

2. **DC power supply connector**

Connect a 48 VDC power supply (42 V - 57 V) to the power supply connector.

3. **BGM control input** – only available in versions with extended functionality:

SMART-PA8080E / SMART-PA4160E / SMART-PA8160E / SMART-PA1650E / SMART-PA2650E

The control input connector, labelled BGM CTRL 1-8 on the rear panel of the amplifier, is used to mute any of the eight BGM signals connected to the amplifier. As with the audio input connector, the BGM CTRL 1-8 connector must be connected to the appropriate control unit leads using the cable shown in the drawing.

Pin number	Description
1	BGM 1 mute signal
2	BGM 2 mute signal
3	BGM 3 mute signal
4	BGM 4 mute signal
5	BGM 5 mute signal
6	BGM 6 mute signal
7	BGM 7 mute signal
8	BGM 8 mute signal
9 (not shown on the image)	connection of the amplifier's ground with the terminal shield

All BGM muting control signals are implemented as optocoupler inputs to protect the amplifier and the control unit from possible overvoltages. Applying a low logic state from the control unit to any BGM CTRL input will mute the corresponding BGM signal.

4. Audio inputs

The symmetrical input connector, labelled INPUT CH1 - CH8 on the rear panel of the unit, is used to connect the audio signal to be amplified. In the general case, it should be used to connect the amplifier to the system control unit, using the T568B straight cable shown on the right side of the drawing (top view). The figure below also shows the appearance of the 8P8C (RJ-45) connector together with the pin numbers described in the table below.

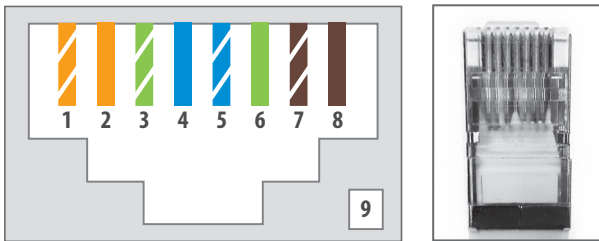

Drawing 43. 8P8C connector (RJ-45)

Pin number	Description
1	audio input signal HOT (+) – signal from control unit
2	audio input signal COLD (-) – signal from control unit
3	signal controlling the correct functioning of the audio path (+) – pilot tone detection by control unit
4*	signal informing the control unit about the amplifier overheating
5**	signal activating the amplifier channel by the control unit
6	signal controlling the correct functioning of the audio path (-) – pilot tone detection by control unit
7*	signal to inform the control unit when fuses are blown
8	control unit's ground
9*** (not shown on the image)	ground connection of the amplifier to the conductive connector housing

* digital signals indicating that the amplifier has overheated and the channel fuses have blown have been implemented as optocoupler outputs to protect the amplifier and the control unit against possible overvoltages during data transmission; overheating or blown fuses are signalled by short-circuiting the corresponding signal to ground of the control unit.

** the digital channel activation signal is implemented in the form of an optocoupler input; activation of the channel is performed by applying a high logic state to the activation input (pin 5).

*** on the PCB there is a jumper enabling the selection of the way of connecting the connector housing to the amplifier grounding; it is possible to connect directly or through a ground-lift circuit, which eliminates possible interferences resulting from different ground potentials of the connected devices.

5. Ground terminal

7.1.6.4 Detailed description of selected functions

BGM control input

The control input connector, labelled BGM CTRL 1-8 on the rear panel of the amplifier, is used to mute any of the eight BGM signals connected to the amplifier via the control unit's control outputs. As with the audio input connector, the BGM CTRL 1-8 connector must be connected to the appropriate control unit outputs using the T568B cable.

All BGM muting control inputs are implemented as optocoupler inputs to protect the amplifier and the control unit from possible overvoltages. Applying a low logic state from the control unit to any BGM CTRL input will mute the corresponding BGM signal.

BGM modules are available only in: SMART-PA8080E / SMART-PA4160E / SMART-PA8160E / SMART-PA1650E / SMART-PA2650E.

„Ground lift” option

Each of the audio inputs is equipped with a ‚ground lift’ option. On the PCB, inside the unit, there is a jumper which allows you to choose how the ground shield is connected to the ground of the amplifier; it is possible to connect directly or via a ‚ground-lift’ circuit, which minimises possible interference from connected devices with different ground potentials.

Amplifier input channel bridging

Two or four channels of one unit can be combined to provide one channel with more power.

If it is necessary to change the output power configuration of individual amplifier channels, the input and output signals should be bridged.

7.1.6.5 Bridging

It is possible to bridge two or four output channels of an amplifier to achieve double or four times the power. To do this, the two output channels of the amplifier must be connected in series, bearing in mind the nominal power of the speaker lines to be connected later. An example of a bridged connection of the output channels is shown in the diagram below. When bridging four channels, we connect two such sets in parallel.

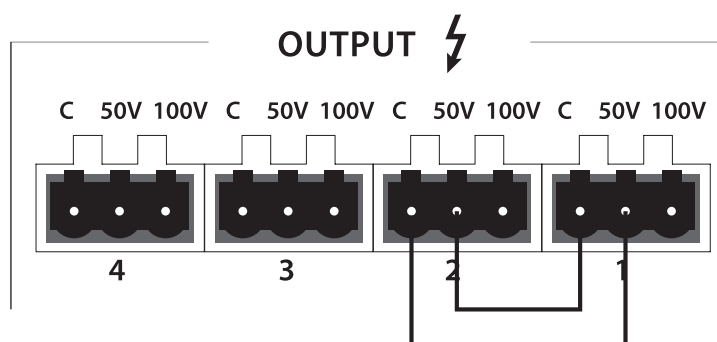

Drawing 44. Bridging of channel 1 & 2 outputs (100 V line)

If the output configuration of the amplifier channels needs to be changed, the input signals must also be bridged. To bridge two channels, use the tee shown in next picture. To bridge 4 channels, use 3 of these elements.

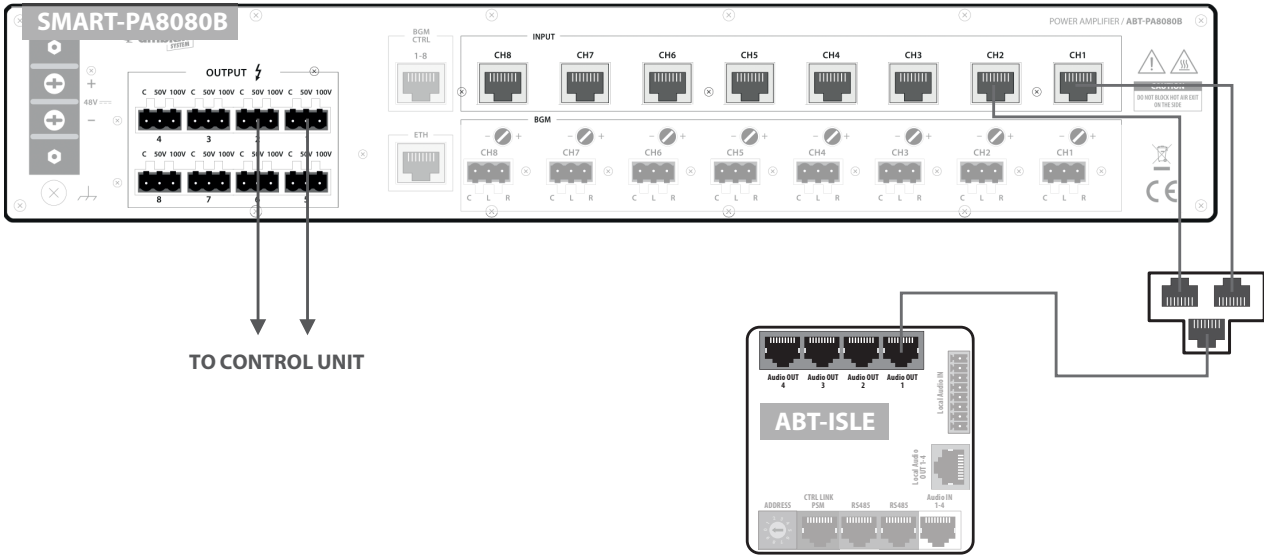

Drawing 45. Bridging two amplifier channels

7.1.6.6 Initial commissioning

As you make sure the input and output connections of audio signal have been made correctly, connect voltage of between 42 and 57 V DC to the amplifier power supply connectors and earth the equipment with the connector available on the rear panel. Be sure that your power supply is suitable for powering the amplifier.

The system is activated approximately 3 seconds after the power is switched on. This is normal operation of the amplifier due to the operation of the built-in automatic protection of circuits, speakers and other connected components. Correct activation of the amplifier module is indicated by the „POWER“ and „ACTIVE“ LEDs on the front panel of the unit.

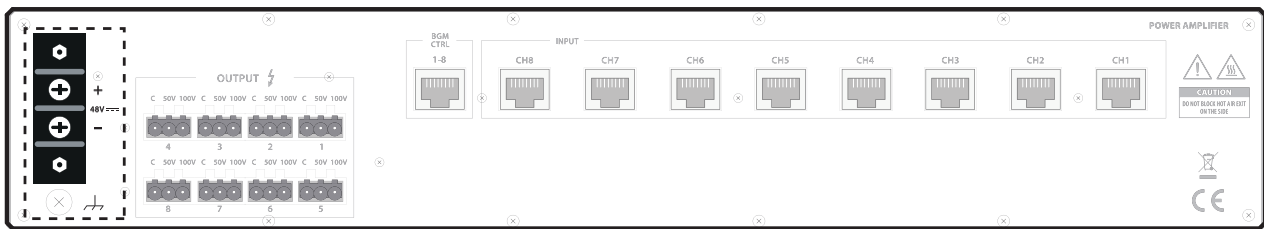

Drawing 46. 48 V DC supply and ground connectors

7.1.6.7 Technical data

Table 13. SMART-PA8080 technical data

Model	SMART-PA8080
Specifications	
Type	Class D
Audio channels	8
Possible configurations	8 × 80 W 6 × 80 W + 1 × 160 W 4 × 80 W + 2 × 160 W 2 × 80 W + 3 × 160 W 4 × 160 W 2 × 320 W
Output voltage standards	50 V 100 V
Supply voltage	DC
Weight	15 kg
Dimensions (W × H × D)	440 mm × 80 mm × 380 mm
Parameters	
Supply voltage	48 V (42-57 VDC)
Rated load (100 V)	125 Ω + 100 nF
Maximum power consumption	1140 W
Rated current	20 A
Current consumption (idle)	0,57 A
Current consumption (channels off)	0,15 A
Frequency response (-3 dB)	75 Hz – 20 kHz
Channel separation	>70 dB
Signal-to-noise ratio	>80 dB (A curve)
Total harmonic distortion THD (rated load/1 kHz)	0,01%
Input impedance	22 kΩ (balanced)
Input sensitivity adjustment	MUTE, -24 dB ... +0,5 dB
Operation conditions	
Ambient temperature	-8°C / 60°C
Ambient relative humidity	10% to 90% (non-condensing)

Table 14. SMART-PA8160 amplifier parameters

Model	SMART-PA8160
Specifications	
Type	Class D
Audio channels	8 (4 for SMART-PA8160 [4CH])
Possible configurations	8 × 160 W 6 × 160 W + 1 × 320 W 4 × 160 W + 2 × 320 W 2 × 160 W + 3 × 320 W 4 × 320 W 2 × 640 W 4 × 160 W (for SMART-PA8160 [4CH]) 2 × 320 W (for SMART-PA8160 [4CH])
Output voltage standards	50 V 100 V
Supply voltage	DC
Weight	18,6 kg
Dimensions (W × H × D)	440 mm × 80 mm × 380 mm
Parameters	
Supply voltage	48 V (42-57 VDC)
Rated load (100 V)	62 Ω + 200 nF
Maximum power consumption	2166 W
Rated current	38 A
Current consumption (idle)	0,57 A
Current consumption (channels off)	0,15 A
Frequency response (-3 dB)	75 Hz – 20 kHz
Channel separation	>70 dB
Signal-to-noise ratio	>80 dB (A curve)
Total harmonic distortion THD (rated load/1 kHz)	0,01%
Input impedance	22 kΩ (balanced)
Input sensitivity adjustment	MUTE, -24 dB ... +0,5 dB
Operation conditions	
Ambient temperature	-8°C / 60°C
Ambient relative humidity	10% to 90% (non-condensing)

Table 15. SMART-PA2650 technical data

Model	SMART-PA2650
Specifications	
Type	Class D
Audio channels	2 (1 for SMART-PA-2650 [1CH])
Possible configurations	2 × 650 W 1 × 1300 W 1 × 650 W (for SMART-PA-2650 [1CH])
Output voltage standards	50 V 100 V
Supply voltage	DC
Weight	15 kg
Dimensions (W × H × D)	440 mm × 80 mm × 380 mm
Parameters	
Supply voltage	48 V (42-57 VDC)
Rated load (100 V)	15,4 Ω + 200 nF
Maximum power consumption	2166 W
Rated current	38 A
Current consumption (idle)	0,33 A
Current consumption (channels off)	0,15 A
Frequency response (-3 dB)	75 Hz – 22 kHz
Channel separation	>70 dB
Signal-to-noise ratio	>80 dB (A curve)
Total harmonic distortion THD (rated load/1 kHz)	0,01%
Input impedance	22 kΩ (balanced)
Input sensitivity adjustment	MUTE, -24 dB ... +0,5dB
Operation conditions	
Ambient temperature	-8°C / 60°C
Ambient relative humidity	10% to 90% (non-condensing)

7.1.6.8 Service

Device maintenance

Due to dangerous voltages inside the working amplifier, maintenance operations should only be carried out after disconnecting the unit from the power supply. In case of dustiness inside the amplifier, it is recommended to clean it with compressed air. It is allowed to clean the outside of the enclosure with a soft cloth.

Service repairs

All repairs of the unit are carried out by the manufacturer or a service centre authorised by the manufacturer. Repair requests should be made by contacting the device manufacturer (www.ambientsystem.eu).

7.1.6.9 Usage recommendations

Storage and packaging

Store unused equipment in its original packaging, indoors at an ambient temperature of -8°C / 60°C and a relative humidity of 10% / 90% (non-condensing).

During transport the amplifier should always be packed in a way that minimizes the effects of possible mechanical damage and the influence of weather conditions.

The packaging should also be marked with the type and manufacturer of the appliance, the weight, the year of manufacture and additional markings indicating the type of the transport (CAUTION: FRAGILE, PROTECT FROM MOISTURE, THIS SIDE UP).

Transport

The amplifier packed as recommended should be transported by covered means of transport. The device should be secured against shifting, in the orientation as indicated on the packaging.

7.1.6.10 Manufacturer's notes

The manufacturer reserves the right to make design and technological changes to subsequent versions of the device.

Handling of packaging and waste equipment

The packaging components of the appliance are made of cardboard and polyethylene foam and can be recycled after use. To this end, unnecessary packaging should be sorted according to its purpose and delivered to the nearest waste collector.

According to the Waste Electrical and Electronic Equipment Act of 11 September 2015, it is not permissible to dispose of a used amplifier together with other (municipal) waste, as there are criminal penalties for such actions. The owner of the used equipment is obliged to return the amplifier to a waste electrical and electronic equipment collector. Appropriate handling of waste equipment contributes to avoiding harmful effects to human health and the environment resulting from improper storage and processing of such equipment.

7.1.7 ABT-ISLE audio/RS interface

The audio/RS interface (connection module) is a distributor of audio signals. These modules are mounted on DIN TH35 rails.



Drawing 47. ABT-ISLE

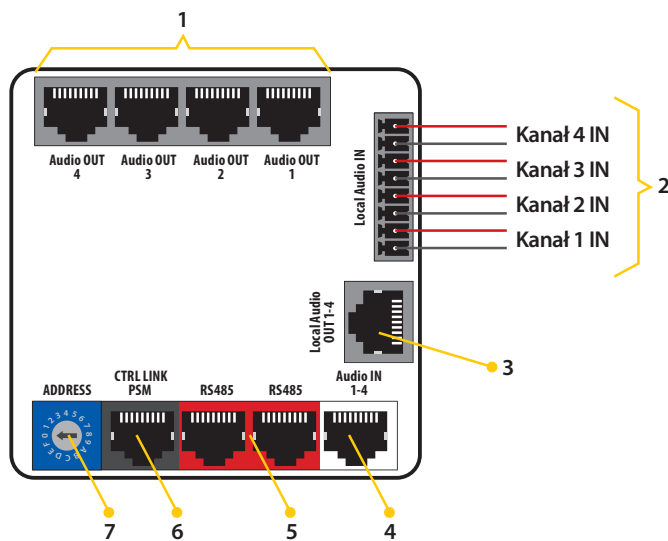

Drawing 48. ABT-ISLE connectors diagram

1. **Amplifier outputs** – RJ-45 connector for 4 amplifier channels.
2. **Local Audio IN** – 4 input channels on 8 pin connector. Phoenix connectors can be used to connect audio sources more easily and quickly. The LOCAL AUDIO IN socket (8 pin Phoenix connector) is bridged with the LOCAL AUDIO OUT (RJ-45). If you wish to connect an external audio source to the system, connect the signal cable to the LOCAL AUDIO IN socket.
3. **Local Audio OUT** – RJ-45 connector for the input signals to the function card connection.
4. **Audio IN** – RJ-45 connector for AUDIO IN 1-4 on the audio card in the CU.
5. **RS485** – ports for communication with the control unit and for connecting further ABT-ISLE modules.
6. **CTRL LINK PSM** – RJ-45 connector for power supply manager connection.
7. **Address setting** – element for assigning an address to the device. The number of addresses ranges from 0-F (16 addresses). Each module connected to one control unit must have its own individual address. The module to which the PSM is connected must start addressing (address set to 0).

⚠ WARNING! All cables used to connect the RJ-45 connectors on the ABT-ISLE must be of the T568B straight type standard. The use of cabling of a different standard (e.g. cross) may result in damage to system components.

7.1.8 SMART-PSM48/E Power Supply Manager

The SMART-PSM48/E Power Supply Manager is used to distribute 48 VDC and 24 VDC guaranteed main and backup power with a total maximum power of 3.2 kW.

⚠ The only difference between SMART-PSM48 and SMART-PSM48E is the lack of 6 × 24VDC outputs in SMART-PSM48.

External 800 W SMART-PS48800 switched-mode power supply modules are used as the main source of distributed power, while a battery bank with a capacity of up to 4 x200 Ah is used for backup power. 12 V batteries with a capacity of less than 40 Ah can only be used for public address purposes. The SMART-PSM48 can work with up to 4 SMART-PS48800 power supply modules, ensuring they are securely connected for operation and controlling the output parameters of each power supply. The SMART-PSM48 cooperates with a battery bank of 4x12 V VRLA batteries, keeps them charged by providing temperature compensation of charging parameters and controls the serial resistance of the batteries and their connections in accordance with Annex A2 to EN 54-4. The system elements are designed for mounting in a 19" IP30 rack, with other elements of the fire detection and fire alarm system also built in.

SMART-PSM48 provides uninterruptible switching to a back-up power source when there is a mains power loss or failure of the SMART-PS48800 external power supply modules. The manager is designed for systems requiring a backup power source, including those compliant with EN 54-16 Voice Alarming Systems (VAS).

The maximum configuration of the VAS power supply system complying with EN 54-16 includes:

- » **1 × SMART-PSM48 – Power Supply Manager,**
- » **4 × SMART-PS48800 – Power Supply Unit,**
- » **1 × SMART-PF4 – Power Supply Unit Frame.**

7.1.8.1 Unpacking the equipment

Please read this manual to familiarise yourself with the relevant information on installation, operation and product characteristics and features.

As with most electronic devices, if you need to return the product to a service centre, you are required to pack the device in the original packaging (or identical to the original packaging).

The package contains:

- » SMART-PSM48 power supply manager module / SMART-PS48800 power supply module/ SMART-PF4 power supply frame;
- » thermistor;
- » cables as per IEC 60320 C13;
- » fuses;
- » connectors;
- » user manual;
- » technical documentation.

7.1.8.2 Installation

Environmental conditions

Do not place the product in an environment that may negatively affect the functioning of the device or reduce its correct operation time. Environments that affect the equipment negatively are usually characterised by high levels of temperature, dust, humidity and vibration.

Important safety instructions

1. Read these instructions.
2. Keep these instructions.
3. Pay close attention to warnings.
4. Follow all points in the instructions.
5. Do not use the device near water.
6. Use only dry material for cleaning.
7. Avoid covering the ventilation holes of the unit housing. Carry out the installation in accordance with the manufacturer's instructions.
8. Do not install the unit near heat sources such as radiators, cookers, radiators or other heat emitting devices (e.g. amplifiers).
9. Do not connect the device to an outlet without a grounding pin.
10. Protect the power cable from being pressed, bent or crushed, especially in the areas near plugs, sockets and the area on the device housing from which the cable is routed.
11. Only use accessories and additional parts specified by the manufacturer.
12. Only use the equipment with the tripods, supports, tables, trolleys specified by the manufacturer. If you are using the equipment on a tripod, table or trolley, take extra care to ensure that the equipment does not tip over when moved.
13. Unplug the appliance from the power socket during a thunderstorm and if the appliance is not in use for a long time.
14. For servicing, consult qualified service personnel. Servicing is required in the event of any type of damage to the equipment, such as damage to the power cable or plug, spillage of liquids, ingress of small objects into the enclosure, exposure of the equipment to rain or moisture, dropping the equipment or incorrect operation.

⚠ AVOID EXCESSIVE HEAT, HUMIDITY, DUST AND VIBRATION

Keep the device away from areas exposed to high temperatures and humidity (radiators, cookers, washbasins, etc.) and places subject to excessive dust, dust and vibration.

⚠ AVOID MECHANICAL SHOCKS

Strong impacts and shocks can damage the equipment. Handle and carry the equipment carefully, avoiding dropping it..

⚠ DO NOT OPEN THE CASE, DO NOT ATTEMPT TO REPAIR OR MODIFY THE DEVICE YOURSELF

The equipment does not contain any user-serviceable parts for disassembly or repair. For maintenance and servicing of the equipment, contact qualified service personnel. Opening the unit's housing by yourself or interfering with internal components voids the warranty.

⚠ ALWAYS DISCONNECT THE POWER BEFORE CONNECTING OTHER DEVICES

To avoid damage to the device and the accessories connected to that device, always switch off the power supply at the device's main switch before connecting or disconnecting cables.

⚠ HANDLE WIRES WITH CARE

Connect and disconnect all cables (including the power cord) by pulling on the plug, not on the cable.

⚠ USE DRY, SOFT MATERIAL FOR CLEANING

Never use solvents such as petrol or thinner for cleaning. Clean the unit with a dry, soft cloth.

7.1.8.3 Installation and connection

General comments

Installation, connection and configuration of the devices should be carried out in accordance with this manual. When making subsequent connections, careful attention should be paid to the polarity of the wires, as incorrect connections may result in damage to the manager or power supplies. Before commissioning the power supply system, it is necessary to check the validity of all connections made.

Installation

The system components are designed for mounting in a 19" IP30 rack. The power supplies should be mounted in a dedicated SMART-PF4 frame.

The maximum configuration of the VAS power supply system complying with EN 54-16 includes:

- » 1 × SMART-PSM48 – power supply manager,
- » 4 × SMART-PS48800 – power supply units,
- » 1 × SMART-PF4 – power supply frame.

Connecting

Firstly, ground the power manager via the terminal available on the rear panel. Next, connect the required number of SMART-PS48800 power supplies to the DC 52 V inputs located on the rear panel of the SMART-PSM48 manager, taking care to note the polarity of the wires. The drawing below shows the maximum configuration of the power supply system, containing four attached power supplies.

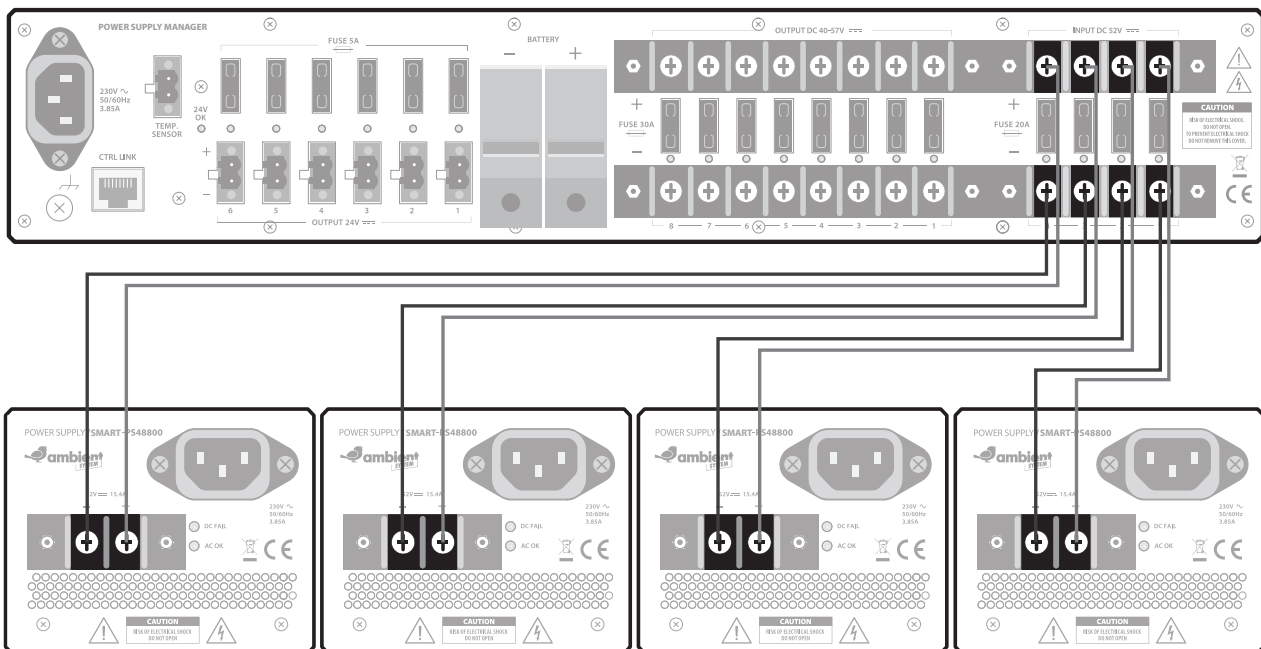

Drawing 49. Connection of power supply modules to the power manager

In the next step, connect the four series-connected 12 V VRLA batteries to the pair of battery terminals located on the rear panel of the SMART-PSM48 manager, paying attention to the polarity of the wires. In addition, a thermistor temperature sensor must be connected by attaching its cable to the TEMP SENSOR connector and locating the sensor in the location of the batteries. Only new and unused batteries may be connected (of the same manufacturer, same capacity and voltage, same date of manufacture).

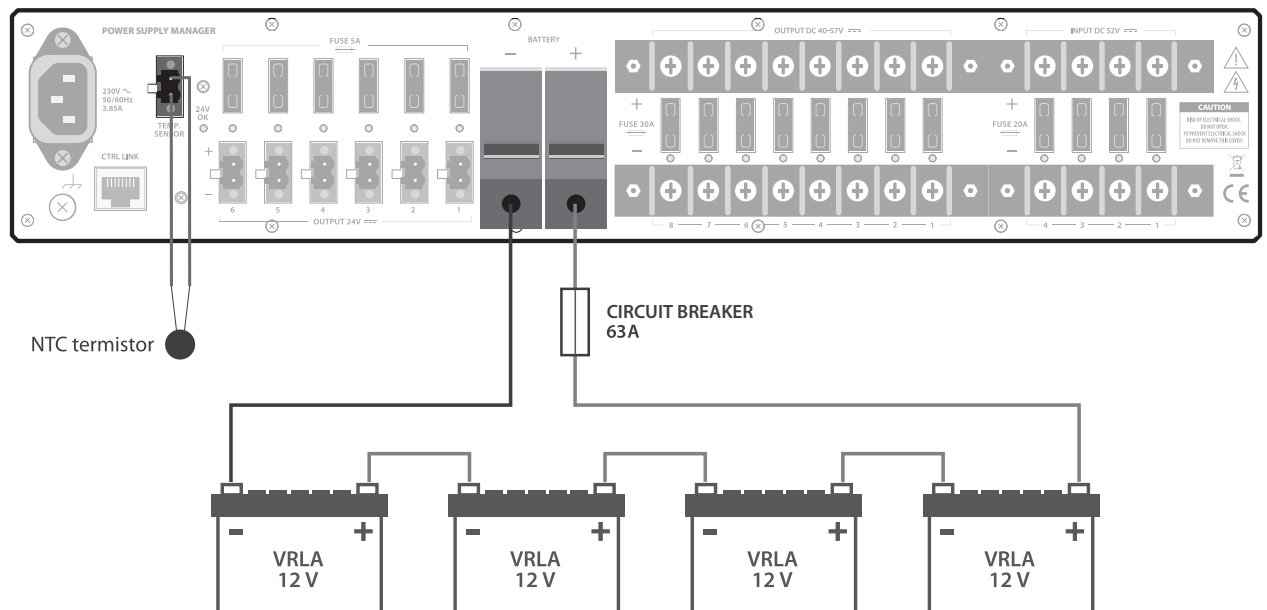

Drawing 50. Connection of the battery pack to the power manager

Use 1 × 63 A overcurrent circuit breaker, DIN rail, (positive lead) in the battery bank circuit.

Details of configuration, front panel operation and menus are described in the relevant User Manual.

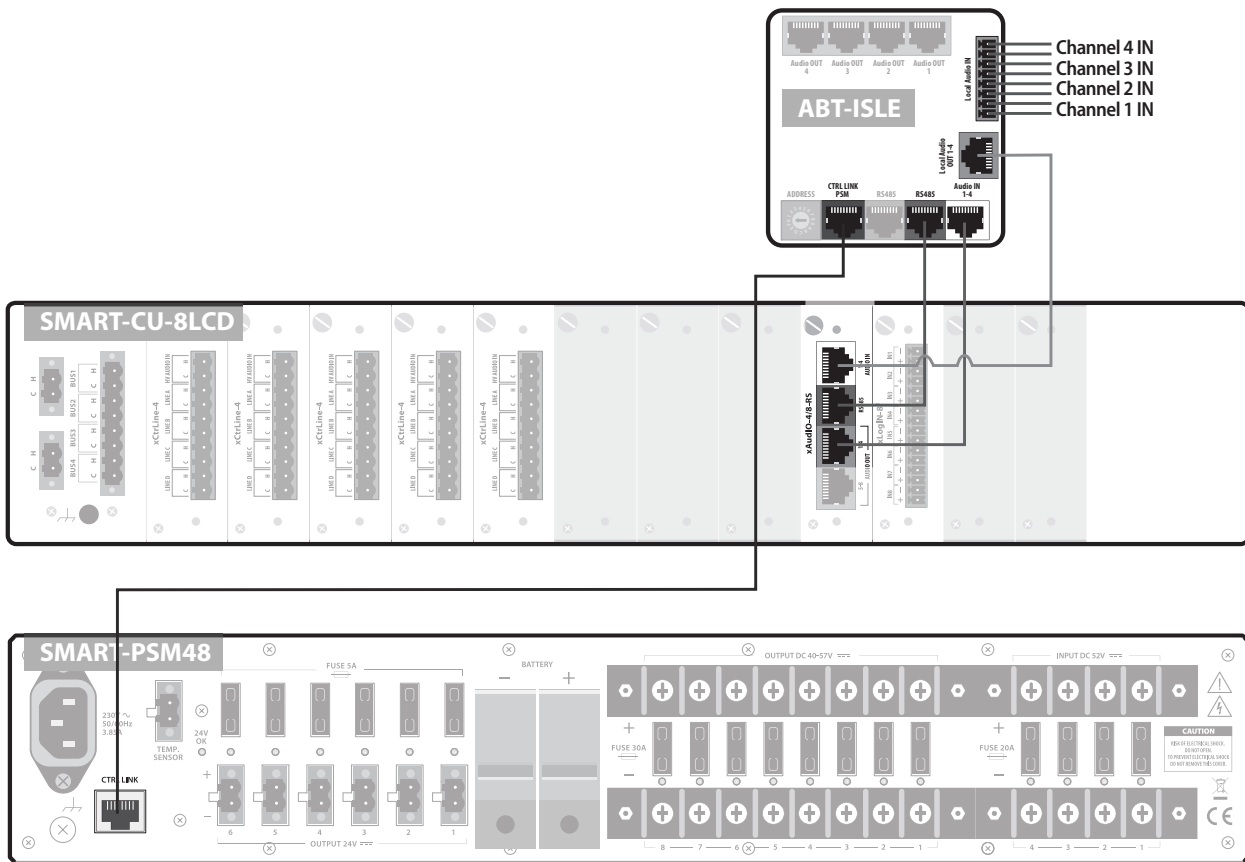

Drawing 51. Connection of CTRL LINK SMART-PSM48 with smartVES control unit via audio/RS interface ABT-ISLE

7.1.8.4 Front panel

The drawing shows the appearance of the front panel of the manager module, together with the labels of its most important elements.

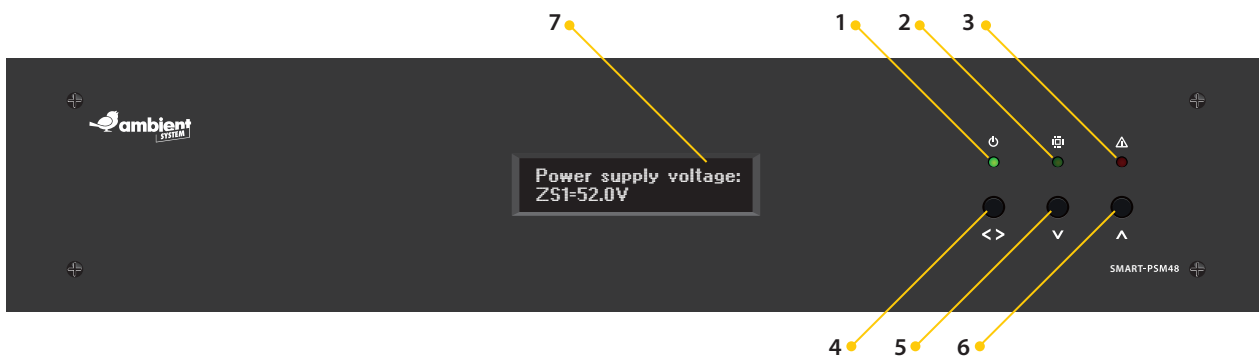

Drawing 52. SMART-PSM48 power supply manager front panel

1. **Power supply**
LED indicating power connection to the manager module
2. **Active**
LED indicating correct operation of the manager
3. **Failure**

- LED indicating a power supply failure
4. **Enter/exit button**
Manager's menu operation button
 5. **Down arrow button**
Manager's menu navigation button
 6. **Up arrow button**
Manager's menu navigation button
 7. **Display**
Manager's menu display

The operation of the menu using the buttons available on the front panel is shown in the following subsection.

7.1.8.5 Front panel operation

Typical operation of the supply system is limited to specifying the number of power supplies and setting the parameters of the connected batteries. The drawings below show a fragment of the front panel of the power supply manager including buttons and LEDs indicating the module status and a diagram of the menu structure in the form of information available on the alphanumeric display.

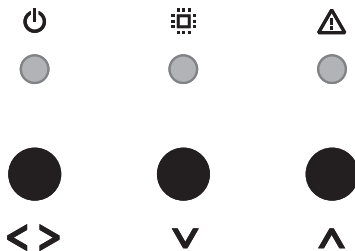

Drawing 53. Front panel buttons

The front panel buttons are used to control the unit using the menu. Holding down a button for a longer time (>1s) activates its second function. This is confirmed by interrupting the Active LED illumination. The menu makes it possible to view the status of the power supplies, the charger, the fuses and the battery bank, to measure the serial resistance of the batteries, to check the battery temperature, to view the list of recorded device faults and to check the software version of the manager. There is also a service mode, from which it is possible to select the number of power supplies supported, activate the battery protection system and set the battery capacity. The method of navigating the menu using the buttons is described below.

ENTER – press <> button and hold for 1 s,

EXIT – press <> button,

ON-DEMAND RESISTANCE MEASUREMENT – using the arrows in the main menu, select the „Serial resistance“ option, then press the <> button and wait for the measurement result,

VIEWING THE FAILURE LOG – use the arrows to select the desired option from the menu items and then press the <> button,

ENTERING SERVICE MODE – press the <> button and the up arrow button simultaneously and hold for approx. 1 s. The service password is 1992. In the service mode it is possible to edit the number of connected power supplies, to activate battery protection and to define the capacity of the connected battery bank. The settings are changed by selecting the option with the arrows, entering the edit mode (ENTER button), changing the option and confirming (ENTER button).

DEVICE RESET – press the up and down arrow keys simultaneously and hold for approx. 3 seconds.

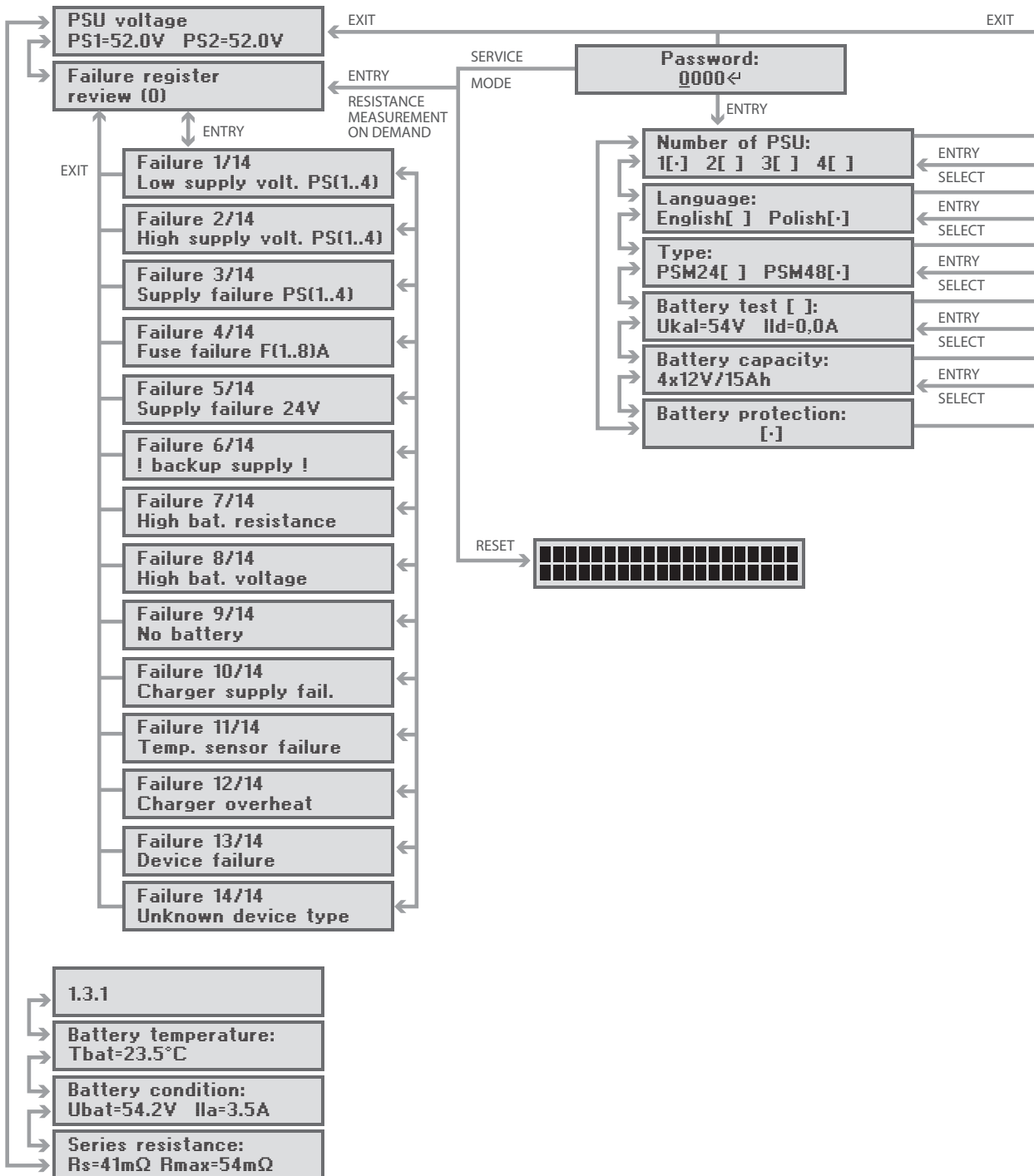

Drawing 54. Block diagram of the power manager menu structure

7.1.8.6 Rear panel

The picture shows the appearance of the rear panel with the applied connector markings.

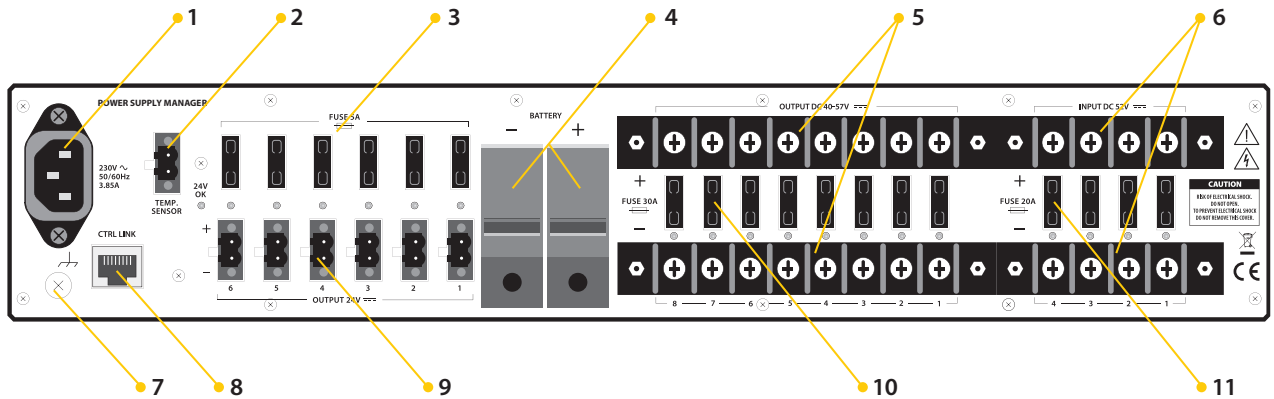

Drawing 55. SMART-PSM48/E power supply manager rear panel

1. **Mains power connector**
The power connector is used to connect the mains cable
2. **Battery temperature sensor connector**
The temperature sensor connector is used to attach a thermistor to monitor the ambient temperature of the battery bank
3. **24 VDC power supply output circuit fuses (5 A, 32 VDC) – only available in version with extended functionality SMART-PSM48E**
Fuses are used for overcurrent protection of the 24 VDC power supply outputs
4. **48 VDC battery terminals (40 - 57 VDC)**
The battery terminal is used to connect a battery as backup power source
5. **Power supply output connectors (40 - 57 VDC)**
The power output connectors provide an output voltage in the range of 40 - 57 VDC
6. **Input connectors for 52 VDC power supplies**
Input terminals are used to connect 52 VDC power supplies
7. **Ground terminal**
The connector is used to ground the device
8. **Communication interface with the system manager**
The communication interface is used to transmit status signals on power supplies, batteries and serial resistance values (DC FAIL, AC FAIL, BATTERY FAIL)

The communication connector should be connected to the corresponding pins of the system control unit, using the T568B straight cable shown on the right-hand side of the figure. The appearance of the 8P8C (RJ-45) connector described below is also shown, together with the pin numbers, the meaning of which is described in the table below.

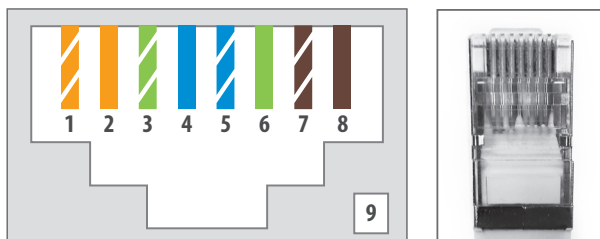

Drawing 56. CTRL LINK connector wiring

Pin	Wire colour	Function
1	white and orange	ground connection
2*	orange	battery fault signal
3*	white and green	general fault signal
4*	blue	mains operation signal
5*	white and blue	mains fault signal
6	green	+3,3 V
7	white and brown	not used
8**	brown	battery test trigger signal
9	shield	ground connection of the device to the conductive connector housing

* digital signals indicating faults, failures and activation of the back-up power supply have been implemented in the form of optocoupler outputs, in order to protect the power manager and the control unit from possible overvoltages during data transmission; the indication of a fault or failure is made by short-circuiting the corresponding signal with the ground of the control unit.

** the digital trigger signal for testing the battery bank is realised in the form of an optocoupler input; the test is triggered by applying a low logic state to the activation input (pin 8).

9. **24 V DC power supply output connectors** – *only available in SMART-PSM48E version with extended functionality*
The power output connectors provide an output voltage of 24 VDC.
10. **Power supply output circuit fuses (30 A, 80 VDC)**
The fuses are used for overcurrent protection of the 40 - 57 VDC power supply outputs.
11. **Power supply input circuit fuses 52 VDC (20 A, 80 VDC)**
Fuses are used for overcurrent protection of power supply inputs.

Details on configuration, front panel operation and menu operation are described in the relevant User Manual.

Table 16. Technical specifications of the SMART-PSM48 power supply manager

Model	SMART-PSM48
Electrical parameters	
AC power supply	230 V AC +10% -15%, 50/60 Hz, 3,85 A cable with IEC 60320 C13 3x0.75 mm ² connector (included in delivery)
Maximum power consumption	885 W
Rated power efficiency	> 90%
AC input protection	T6.3 A/250 V 5x20 mm delayed fuse (accessible after opening the enclosure)
Protection against electric shock	Class I (EN 60065)
Current consumption (DC idle)	120 mA
DC inputs	4, M4 DEGSON screw terminals, raster 13 mm, Dedicated power supply unit (SMART-PS48800)
DC input protection	4 × 20 A 80 VDC fuse
DC outputs	8 × 48 V, M4 DEGSON screw terminals, 13 mm grid pattern, each output provides 40 - 57.6 V DC (values depend on the voltages present on the batteries during charge/discharge operation), 30 A max. 6 × 24 V, Phoenix 2 pin connectors, 5.08 mm pitch each output provides 24 V, 5 A max. (the load of all 6 outputs combined must not exceed 6 A - 144 W) (only for SMART-PSM48E)

DC output protection	48 V outputs: 8 × 30 A 80 V DC fuse 24 V outputs: 6 × 5 A 32 V DC fuse (only for SMART-PSM48E)
Maximum total load of the DC outputs (24 V and 40 - 57.6 V)	The total load of all DC outputs should not exceed 60 A at 40 V DC (2.4 kW max.)
Backup power supply	
Batteries type	4 pcs. VRLA 12 V 15-200 Ah
Charging method	fixed-voltage or multi-stage
Charging current	14 A max.
Charging voltage	54,6 V ± 0,6 V (at 25°C)
Temperature correction factor	-80 mV/ 1°C
Battery connection	2 screw terminals (positive, negative) AWG6 - AWG1/0 connection cable used 4x12 V batteries in series
Charging circuit protection	20 A, 80 V
Battery circuit protection	1 × 63 A DIN-rail overcurrent circuit breaker (positive conductor)
Maximum resistance of connections and fuses	10 mΩ
Maximum total series resistance of connections, fuses and batteries	28 - 60 mΩ (failure trigger threshold set in manager options)
Temperature	
Temperature sensor	Thermistor
Operating temperature	-5°C to +40°C
Performance characteristics	
Finish	front panel steel, powder-coated, black semi-matte, white silk-screen printed
Dimensions	482 (W) × 85 (H) × 443 (D) mm
Weight	7.2 kg
Accessories	IEC 60320 C13 1.5 m power cord temperature sensor

7.1.8.7 Initial start-up

Once you have ensured that the connections have been made correctly (in accordance with Chapter 5), connect the 230 V AC mains voltage wires to the power supply terminals of the manager and power supply unit marked in the figure below. The assembled power supply system is now ready for operation.

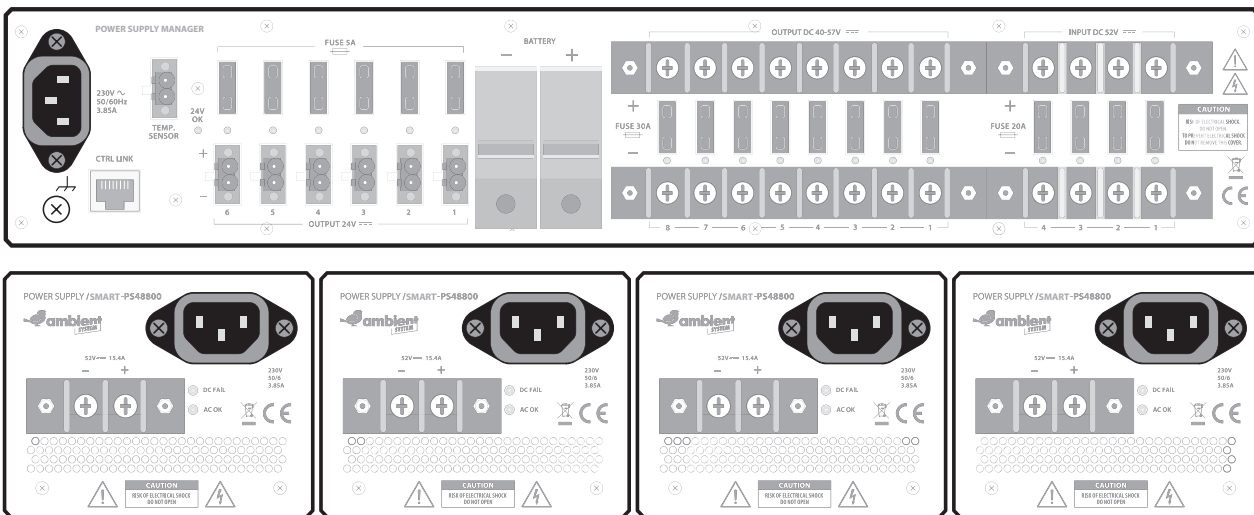

Drawing 57. 230 V AC power supply terminals and earth terminal

Details on configuration, front panel operation and menu operation are described in the relevant User Manual.

Two tests should be performed during the initial start-up:

Checking the ability to sustain the output voltage

Disconnect the mains supply with the switch installed in the electrical installation before the PSU. The PSU should switch to battery operation mode by maintaining voltage at its outputs. Any voltage tester can be used for this purpose, e.g. a voltmeter.

In this condition the fault indication on the front panel should be triggered (details describing the front panel are described in the relevant User Manual). The fault signal should be transmitted to the Voice Alarm System Control Unit.

Battery bank circuit test

With the power supply running from the mains, the battery circuit must be interrupted by disconnecting one of the fuses. This condition will be detected by the power supply at the next test. This may take up to 10 minutes. Similarly, when the interruption is removed, the generated fault indication will be removed automatically, but only after the next correctly performed test - after a maximum of 10 minutes.

In this condition the Fault indication on the front panel of the Power Manager should be triggered. The fault signal should be relayed to the Voice Alarm System Control Unit.

7.1.9 SMART-PS48800 Power Supply Unit

The SMART-PS48800 power supply is a new generation power supply made with pulse technology. The output power of the power supply is 800 W at 48 V.

As an option, the SMART-PS48800 power supply can be used as a stand-alone unit without being mounted in the SMART-PF4 power supply frame and rack.

7.1.9.1 Rear panel

The figure shows the rear panel of a single SMART-PS48800 power supply unit.

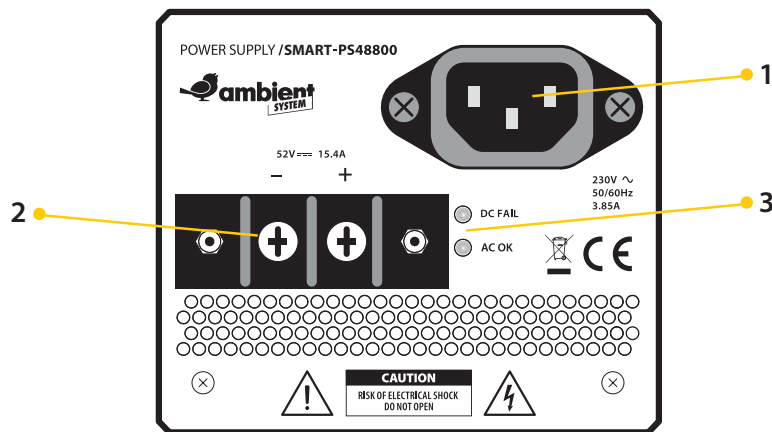

Drawing 58. Rear panel of the SMART-PS48800 power supply unit

1. **Power supply connector 230 V AC 3.85 A**
The power connector is used to connect the mains cable
2. **Power supply output connector 52 V DC 15.4 A**
Power supply output connector provides 52 V DC output voltage
3. **Operating status indicator lights**
The operating status LEDs indicate the status of the PSU - the table shows a description of the LEDs' meaning

DC FAIL	illuminates red when full output voltage is not reached (e.g. overload)
AC OK	illuminates green when AC voltage is sufficient for proper operation

Table 17. SMART-PS48800 technical data

Model	SMART-PS48800
Electrical parameters	
AC power supply	230 V AC +10% -15%, 50/60 Hz, 3.85 A cable with IEC 60320 C13 3x0.75 mm ² connector (supplied)
Maximum power consumption	885 W
Rated power efficiency	> 90%
AC input protection	T6.3 A/250 V 5x20 mm delayed fuse (accessible after opening the enclosure)
Protection against electric shock	Class I (EN 60065)
DC output	M4 DEGSON screw terminal, 13mm grid 52 V DC, 15.4 A max.
Performance characteristics	
Dimensions	85 (W) × 95 (H) × 395 (L) mm
Weight	2.6 kg
Accessories	IEC 60320 C13 1.5 m power cord

7.1.9.2 SMART-PF4 power supply frame

The power supply frame module is designed for mounting power supply modules in a 19" IP30 rack. Four independent SMART-PS48800 power supply units can be mounted in the frame using the screws provided.



Drawing 59. SMART-PF4 power supply frame

7.2 External devices

7.2.1 ABT-DFMS Fireman's microphone

The fireman's microphone is used to:

- » transmission of voice messages or stored warning and evacuation messages to selected zones by a firefighter during a fire action,
- » activation of emergency messages,
- » calling general-purpose messages,
- » selecting individual zones,
- » broadcasting live voice messages.

The microphone is powered locally via a certified fire power supply unit (48 V) or remotely via PoE.

It has programmable action buttons to which selected functions can be assigned in any way. It is also possible to connect up to 5 supervised ABT-EKB-20M extensions with additional action buttons. Up to 253 firefighter microphones can operate in a single system. Communication with the control units takes place via Ethernet via 1000BASE-X or 10/100/1000BASE-T/TX optical fibre links.

An optional function of the system is the „CPU-OFF“ function. The system is then put into a state to transmit a voice message to all alarm zones. The „CPU-OFF“ switch enables immediate and direct broadcast of messages to all zones without the involvement of the control system (even during a central processor failure).

The microphone has automatic detection and indication of faults in the buttons and in the audio signal path from the microphone capsule to the control unit.

A 10-pin socket on the right side panel allows connection of a keyboard extension. The microphone is equipped with 2 SFP module connectors, 2 LAN 10/100/1000 ports, 1 LAN 10/100 port, 1 RS485 port.

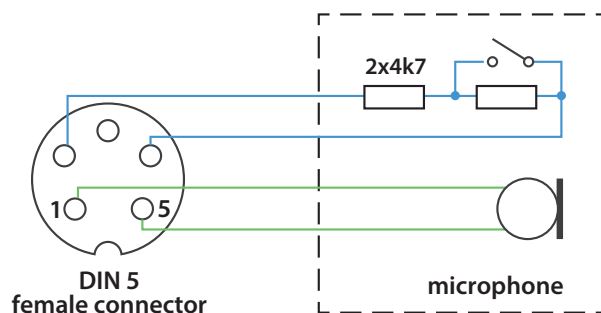

Drawing 60. Microphone plug pin diagram

Main features:

- » Built-in 2 potential-free inputs and 2 relay outputs,
- » Microphone powered locally (48 V) or via POE,
- » Black box function - records the audio signal from the microphone while the system is in alarm mode,
- » Built-in 2 SFP module slots and two RJ45 sockets for easy implementation of loop or star connection,
- » RS485 communication,
- » Intercom function for communication between fireman's and zone microphones.

Main in-system functions:

- » Reporting of hardware faults detected on cards,
- » Reporting of incorrect input voltage level (short or open circuit),
- » Definition of state levels of short/open/high/low for each input,
- » Control of any logic output by any module in the system,
- » Use of the value/status of any input by any module in the system,
- » Calling scenarios, actions through any state of any input,
- » Assign any output to any system event,
- » Defining the NC / NO input type.

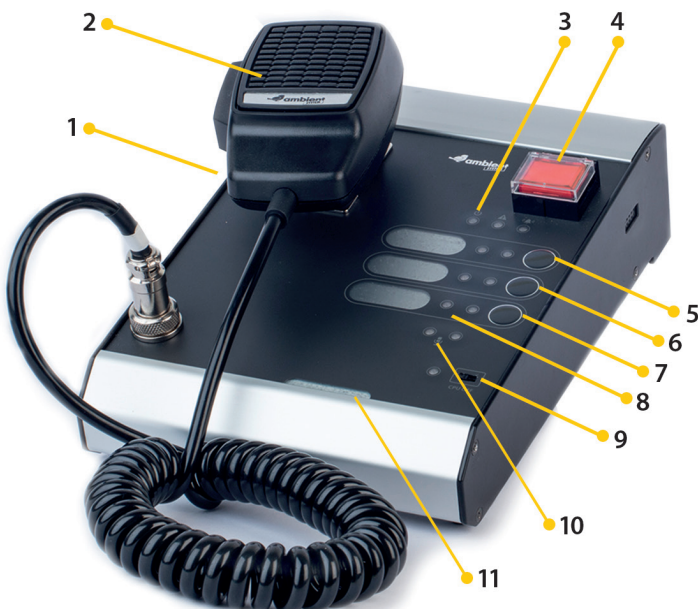

Drawing 61. ABT-DFMS fireman's microphone

1. **Built-in loudspeaker**
2. **Hand-held microphone with push to talk button**
3. **LED indicators for:** Power (green), Fault (yellow), Evacuation (red)
4. **„Emergency Activation” button**
5. **Function button** – can be freely programmed, it is most frequently programmed as „Evacuation”

6. **Function button** – can be freely programmed, it is most frequently programmed as „Alert“
7. **Function button** – can be freely programmed, it is most frequently programmed as „Alarm reset“
8. **LED indicators for function buttons**
9. **CPU-OFF switch** – green LED on indicates active CPU-OFF mode
10. **Transmission ready indicator** – A flashing green LED when the PTT button is pressed indicates that the microphone is ready to broadcast an announcement. If a chime is programmed, the microphone will activate as soon as the chime is played, the green LED will flash
11. **Insertion point for the button label**

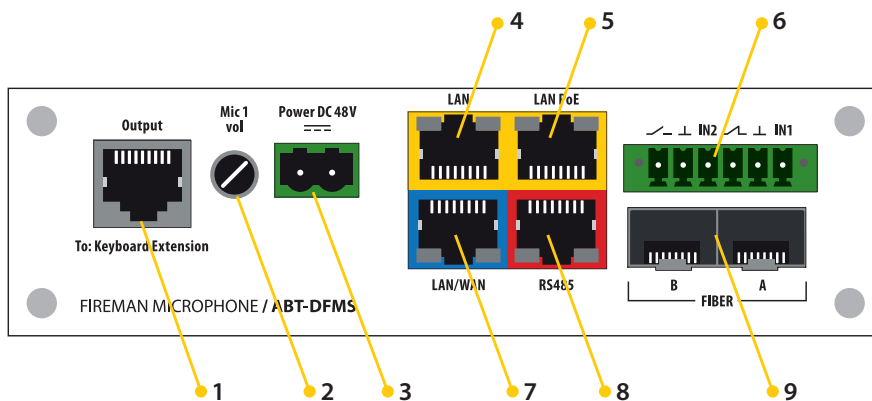

Drawing 62. ABT-DFMS top panel

1. **RJ45 socket** for connecting the microphone extension ABT-EKB-20M
2. **Controller of the hand-held microphone volume level** from -6dB to +6dB
3. **2-pin socket** for EN54-4-compliant power supply
4. **RJ45 socket for LAN connection**
5. **RJ45 socket for LAN connection with PoE** – the microphone can be powered directly from the Control Unit using a single Cat 5 cable (data + power supply)
6. **Phoenix socket, two parametric inputs and two relay outputs** (each channel can be configured independently)
7. **RJ45 socket for LAN/WAN connection** (communication via LAN/WAN port is done using an encrypted protocol)
8. **RJ45 socket** compatible with RS485 transmission standard
9. **Two optical fibre sockets** for SFC type modules, SC/LC type connector

The ABT-DFMS firefighter microphone architecture consists of an ABT-xNET-1Gb/WAN/RS communication card supplemented by a firefighter microphone keypad module, an extension service module and a power supply module.

Table 18. ABT-DFMS fireman's microphone technical data

Model	ABT-DFMS
Power supply	LAN PoE or local power supply in accordance with EN 54-4
Input voltage	48 V, 2-pin 5.08 mm screw connector
Current consumption	max 266 mA for 48 V / 5 keypad extensions
Protection class	31
Transmission medium	Fibre optic cable, UTP cat. 5e
Number of parametric inputs	2
Number of relay outputs	2
Logical outputs/inputs connector	3.5 mm screw connector, 6 pin
Fibre optic connector type and optical fibre type	SFP type module, SC/LC type connector OM2/OM3 single/multi-mode optical fibre
Audio path, Loudspeaker	
Output power	0,5 W
Sound pressure level	78 dBA (@1m, 1W)
Minimum frequency response (3dB)	450 Hz – 8 kHz
Audio input	
Fireman's microphone frequency response	400 Hz – 6 kHz (@3dB)
Impedance	500 Ω
Microphone signal	-40 do 30 dBu
Sensitivity	-66 dB
Cable length and type	≥ 1,5 m, spiral
Microphone connector	5-pin DIN microphone
Keypad and indicators	
Number of buttons	3
Number of button indicators	2 LEDs/button
Space for description at the buttons on the left, dimensions	15 × 25 mm
Three additional normative indicators	power - green / fault - yellow / activity - green
Logical inputs/outputs	
Number of logical inputs/outputs	2/2
Maximum switching current	1 A peak*
Maximum switching voltage	50 V AC/DC peak*
Maximum switching power	30 W*
Parametric input signal source for monitor mode	passive, standard resistors: 4 kΩ↔10 kΩ, 0/1/short-circuit detection
Type of logical input/output sockets	PHOENIX type 6-pin screw terminals, 3.5 mm
CPU-OFF switch	slide switch, two-position, green LED indication
Other parameters	

Operating temperature	0°C to 60°C
Operating humidity	15% to 80%
Storage temperature	-20°C to 70°C
Storage humidity	5% to 95%
Dimensions	150 (W) × 55 (H) × 210 (D) mm

▲ IMPORTANT! Any combination of voltage and current values for DC must not exceed the maximum switching power. Capacitive and inductive loads are not permitted due to the large surge in starting current/voltage, which can significantly exceed the maximum permissible switching current or voltage.

7.2.2 ABT-DMS zone microphone

The zone microphone is used for:

- » calling general-purpose messages,
- » selecting individual zones,
- » broadcasting live voice messages,
- » expanding the number of audio signals available in the system by 4 independent audio inputs,
- » simple integration into other PA systems via a built-in, independent line-out, accessible via a 3.5 mm mini-jack socket,
- » communication with other microphones in the system using the intercom function,
- » using 9 freely programmable buttons and connecting up to 5 ABT-EKB-20M extensions.

The ABT-DMS may only be used for non-alarm purposes. The zone microphone enables intercom functionality (two-way communication between zone microphones). The microphone supports 4 external audio inputs (simultaneous operation of 4 channels), and has a local listening speaker to enable any of the zones to be overheard. It is possible to use a headset type (1 mini-jack for microphone operation, 1 minijack for headphone operation). Communication with the control units is via Ethernet with 10/100BASE-TX connections (1 LAN port. CAT 5e cable). The unit is powered locally (48V) or from the VASCU via PoE.

It has programmable function keys, you can freely assign selected functions, i.e. assigning zones to different keys, naming zones, zone groups, ability to access different messages, volume control, ability to switch music on/off in any selected zone.

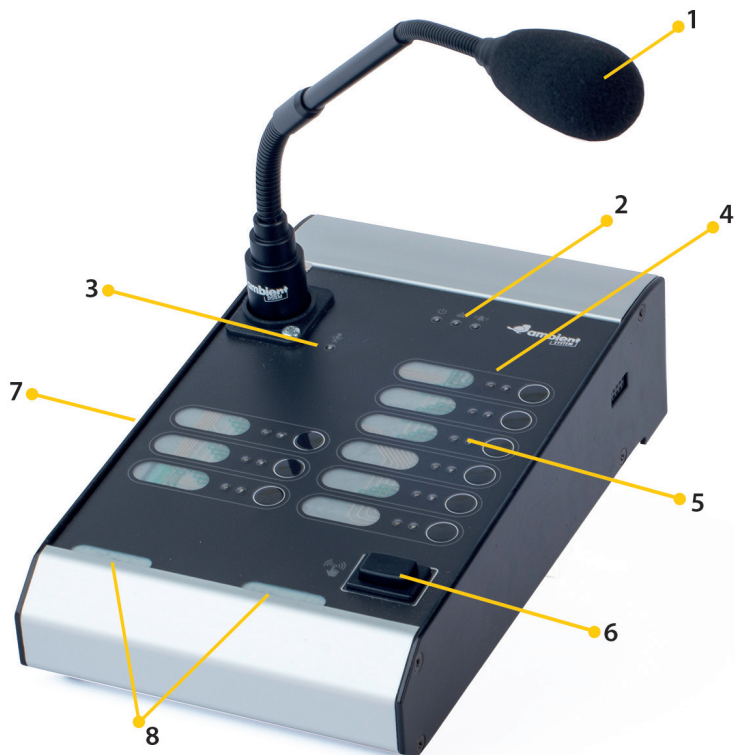

Drawing 63. ABT-DMS zone microphone

1. **Microphone**
2. **LED indicators for:** Power (green), Fault (yellow), Evacuation (red)
3. **Transmission ready indicator** – A flashing green LED when the PTT button is pressed indicates that the microphone is ready to broadcast an announcement. If a chime is programmed, the microphone will activate as soon as the chime is played, the green LED will flash
4. **Function buttons** – freely programmable
5. **LED indicators for function buttons**
6. **Push to talk button** – a button programmed to activate the microphone
7. **Built-in loudspeaker**
8. **Insertion point for the button label**

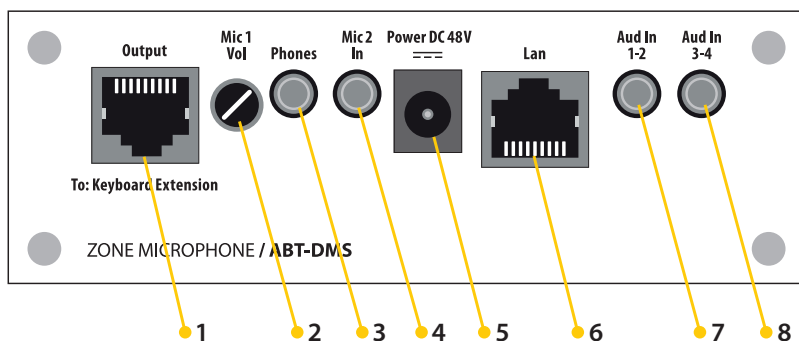

Drawing 64. ABT-DMS top panel

1. **RJ45 socket** for connecting the microphone extension ABT-EKB-20M
2. **Controller of the microphone volume level** from -6dB to +6dB
3. **Headphones socket**
4. **Headset microphone socket**
5. **48 V power supply socket**
6. **RJ45 socket for LAN connection with PoE** – the microphone can be powered directly from the Control Unit using a single Cat 5 cable (data + power supply)
7. **2 Audio inputs**
8. **2 Audio inputs**

Table 19. ABT-DMS zone microphone technical data

Model	ABT-DMS
Power supply	via PoE (RJ45) or by additional 48 V power supply / 15 W DC connector 5,5 / 2,1 mm
Protection rating	IP 31
Number of outputs	2 channel audio (monitor speaker, headset)
Number of inputs	4 channels (single-ended input bgm)
Listening speaker	
Output	0,5 W
SPL	78 dBA (@1 m, 1 W)
Frequency response (3 dB)	450 Hz ... 8 kHz
Output for headphones (headset)	mini-jack 3,5 mm
Audio Inputs	
Input type	single-ended, 4 × bgm
Frequency response	50 Hz ... 18 kHz (@3 dB)
ADC resolution	32 bit
Sampling frequency	48 kHz
Connector	2 × mini-jack 3,5 mm
Microphone input	
Input, connector type	balanced inputs, XLR
Condenser microphone, gooseneck	
Frequency response	100 Hz ... 10 kHz
Sensitivity	-45 dB
Keyboard and controls	
Number of keys	9 + PTT
Additional three normative controls	power – green / failure – yellow / activity – green
LED colors	RGB (red, green, yellow, blue)
Other parameters	

Operating temperature	-8°C to 60°C
Operating humidity	15% to 80%
Storage temperature	-20°C to 70°C
Storage humidity	5% to 95%
Dimensions	120 (W) × 55 (H) × 210 (D) mm
Weight	1,4 kg

7.2.3 ABT-DMS-LCD zone microphone with LCD

The zone microphone is used for:

- » calling general-purpose messages,
- » selecting individual zones,
- » broadcasting live voice messages,
- » expanding the number of audio signals available in the system by 4 independent audio inputs,
- » simple integration into other PA systems via a built-in, independent line-out, accessible via a 3.5 mm mini-jack socket,
- » communication with other microphones in the system using the intercom function,
- » connecting up to 5 ABT-EKB-20M extensions.

The ABT-DMS-LCD microphone is equipped with a touchscreen display for intuitive and easier operation. Navigation through the device's menus and changing its settings is carried out using both the control buttons next to the LCD display and the touchscreen display. THE ABT-DMS-LCD MAY ONLY BE USED FOR NON-ALARM PURPOSES. The zone microphone allows intercom functionality (two-way communication between zone microphones). The microphone supports 4 external audio inputs (simultaneous operation of 4 channels), and has a local pre-listening loudspeaker to listen to one of the zones. It is possible to use a headset type (1 minijack socket for microphone operation, 1 minijack socket for headphone operation). Communication with the control units uses Ethernet with 10/100BASE-TX connections (1 LAN port, CAT 5e cable). The unit is powered locally (48 V) or from the VASCU via PoE.

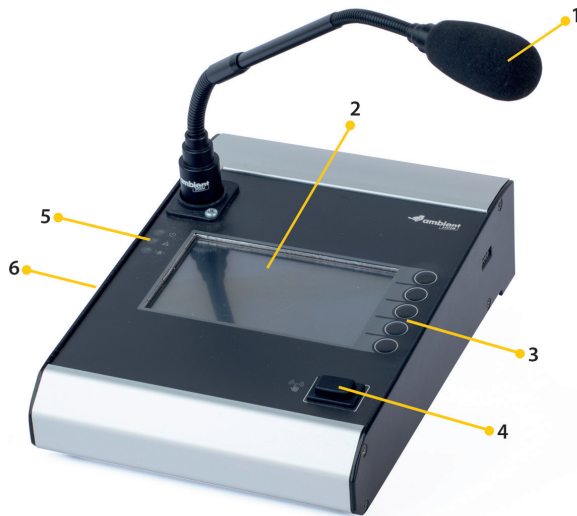

Drawing 65. ABT-DMS-LCD zone microphone with display

1. **Microphone**
2. **Display**
3. **Function buttons for navigating the device menu:**
 - a. HOME - press to return to the main menu,
 - b. ENTER – press to select item in the menu,
 - c. ↑ - up arrow – press to navigate in the microphone menu,
 - d. ↓ - down arrow – press to navigate in the microphone menu,
 - e. BACK – press to return to previous item in the microphone menu.
4. **Push to talk button** – a button programmed to activate the microphone
5. **LED indicators for:** Power (green), Fault (yellow), Evacuation (red)
6. **Built-in loudspeaker**

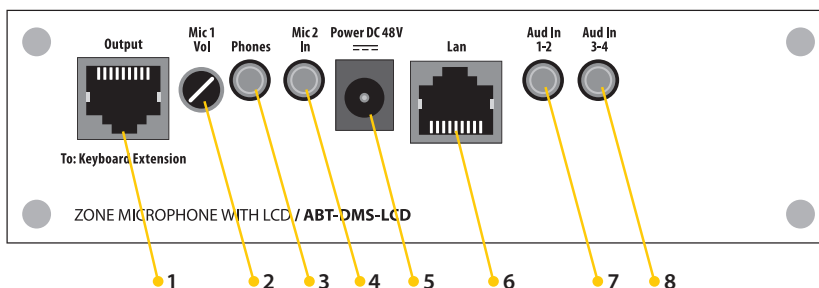

Drawing 66. ABT-DMS-LCD top panel

1. **RJ45 socket** for connecting the microphone extension ABT-EKB-20M
2. **Controller of the microphone volume level** from -6dB to +6dB
3. **Headphones socket**
4. **Headset microphone socket**
5. **48 V power supply socket**
6. **RJ45 socket for LAN connection with PoE** – the microphone can be powered directly from the Control Unit using a single Cat 5 cable (data + power supply)

7. **2 Audio inputs**

8. **2 Audio inputs**

Table 20. ABT-DMS-LCD technical data

Model	ABT-DMS-LCD
Power supply	via PoE (RJ45) or by additional 48 V power supply / 15 W DC connector 5,5 / 2,1 mm
Protection rating	IP 31
LCD	LCD, 272x480 resolution, 4.5 "resistive touchscreen
Number of outputs	2 channel audio (monitor speaker, headset)
Number of inputs	4 channels (single-ended input bgm)
Listening speaker	
Output	0,5 W
SPL	78 dBA (@1 m, 1 W)
Frequency response (3dB)	450 Hz ... 8 kHz
Diameter	50 mm
Output for headphones	mini-jack 3,5 mm
Audio Inputs	
Input type	single-ended, 4 × bgm
Frequency response	50 Hz ... 18 kHz (@3 dB)
ADC resolution	32 bit
Sampling frequency	48 kHz
Connector	2 × mini-jack 3,5 mm
Microphone input	
Input, connector type	balanced inputs, XLR
Condenser microphone, gooseneck	
Frequency response	100 Hz ... 10 kHz
Sensitivity	-45 dB
Keyboard and controls	
Number of keys	5 + PushToTalk
Additional three normative controls	power – green / failure – yellow / activity – green
Other parameters	
Operating temperature	-8°C to 60°C
Operating humidity	15% to 80%
Storage temperature	-20°C to 70°C
Storage humidity	5% to 95%
Dimensions	150 (W) × 55 (H) × 210 (D) mm
Weight	1,4 kg

7.2.4 ABT-EKB-20M microphone keyboard extension

Each extension coupled to a fireman's or zone microphone provides an additional 20 freely programmable function buttons. In accordance with EN 54-16, one of the buttons enables a test to be triggered for the optical and acoustic signalling of the microphone. The extensions connected to the ABT-DFMS fireman's microphone are supervised - the disconnection of any of them will be signalled in the system as a fault (functionality available from FW version 0.750.1).

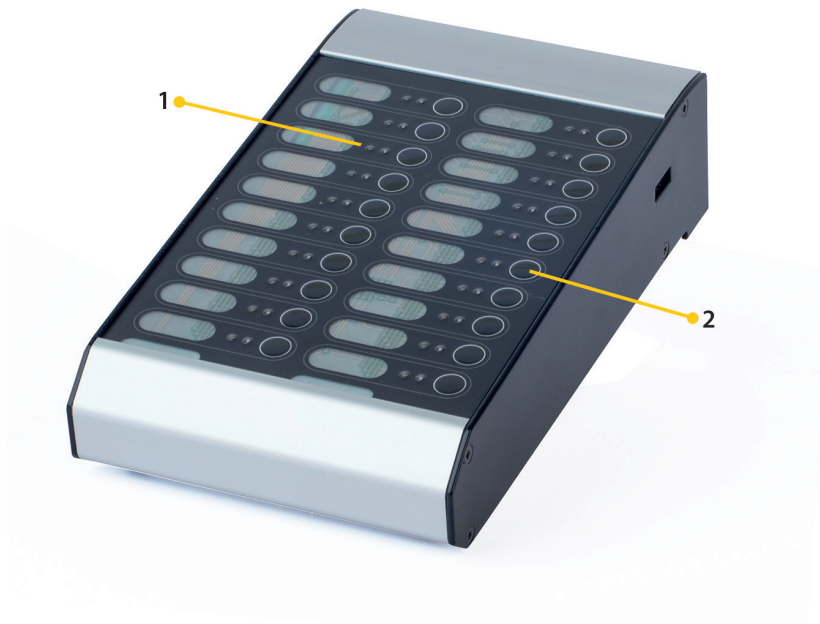

Drawing 67. ABT-EKB-20M microphone keyboard extension

1. **LED indicators for function buttons**
2. **Function buttons** – freely programmable

Table 21. ABT-EKB-20M technical data

Model	ABT-EKB-20M
Power supply	RJ45 from DFMS or DMS
Protection rating	IP 31
Keyboard and controls	
Number of keys	20
Number of LED	20 × RGB + 20 × green
LED color	RGB (red, green, blue) + separate LED green
Other parameters	
Operating temperature	0°C to 60°C
Storage temperature	-20°C to 70°C
Operating humidity	15% to 80%
Storage humidity	5% to 95%
Weight	1,4 kg

Dimensions of the space for the description of the buttons	15 × 25 mm
Dimensions	120 (W) × 55 (H) × 210 (D) mm

7.2.4.1 Functions carried out by function keys

Each function button can be associated with any VAS function that is made available for execution by the user. The function of the button is determined by software, during the configuration of the VAS. Depending on the function assigned to the function button, the meaning of the signalling of the optical indicators associated with the button changes.

Emergency and announcement functions via microphone:

- » Emergency mode,
- » Failure acceptance,
- » Failure delete.

7.2.4.2 Signalling related to the function keys

The signalling associated with a function key depends on its function.

When the button is used to select a zone, the signalling is as follows:

- » **Message broadcast indicator:**
 - › the LED flashes green - when a live message is being broadcast by the firefighter's microphone in the zone,
 - › the LED lights up continuously in green - when a zone is playing:
 - in normal mode, a message transmitted from the zone microphone, background music or alarm cancellation,
 - › the LED flashes red - when a warning message indicating an emergency is being played in the zone,
 - › the LED lights up continuously red - when an automatic evacuation message is played in the zone, ordering the people in the zone to leave the facility immediately,
 - › the LED flashes yellow - when a fault has occurred in the system,
 - › the LED lights up continuously in yellow - when the fault has been accepted or one of the zones has been blocked (optional function from EN 54-16),
 - › the LED flashes blue when intercom communication is requested,
 - › the LED lights up continuously in blue - when intercom communication has been established,
 - › the LED flashes red when a microphone message is being recorded,
 - › the LED lights up continuously - when a recorded message is being played back,
 - › the LED flashes cyan when the microphone is listening to audio from a particular zone,
 - › the LED flashes magenta - when the voice alarm delay is active (optional standard EN 54-16 point 7.4).
- » **Availability / zone selection indicator** – the LED lights up green when the key corresponding to the zone is pressed, indicating that the zone has been selected and that messages from the microphone can be transmitted to the selected zone, or that a message stored in the system memory can be played back.

When the button is associated with fault signalling, the signalling is as follows:

- » **Fault indicators:**
 - › the microphone extension LED flashes and the common fault LED lights up yellow - indicates a failure in the system,
 - › an acoustic signal is generated simultaneously at the microphones and at the Control Units with LED displays: SMART-CU-8LCD and SMART-CU-11LCD,
 - › requires confirmation of the fault by pressing the button next to the flashing LED,

- › when pressed, the LED lights up continuously until the fault is eliminated.

A summary table of the signalling can be found in the chapter: 9 Operating modes - LED colours.

7.2.4.3 Connecting a microphone and keyboard extension

Microphones and microphone extensions are supplied with an aluminium connector.

The ABT-DFMS microphone and the ABT-DMS-LCD microphone must be connected to the ABT-EKB extension with an aluminium connector (136.5 × 30 × 3 mm) using two M3 × 8 mm screws.

The ABT-DMS microphone and each subsequent ABT-EKB extension must be connected with an aluminium connector (124 × 30 × 3 mm) using two M3 × 8 mm screws.

The method of installation is shown in the drawings below:

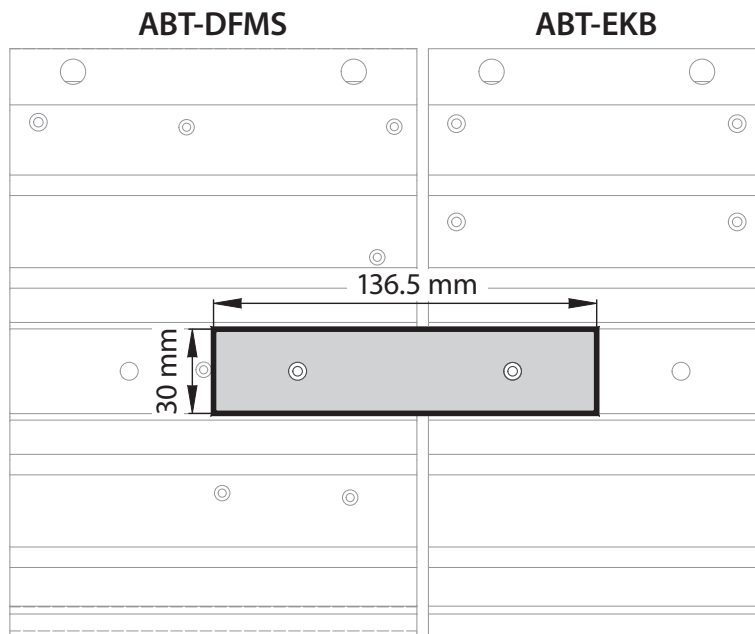

ABT-DMS

ABT-EKB

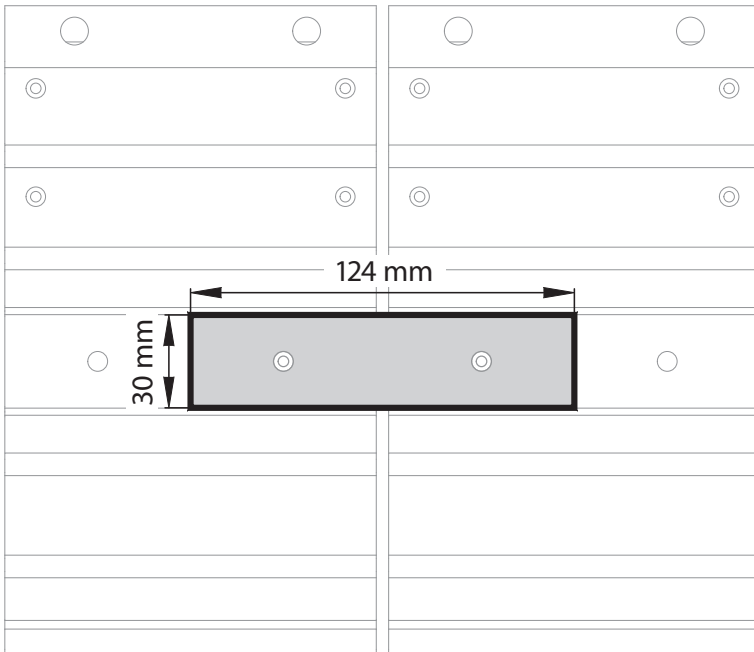

ABT-DMS-LCD

ABT-EKB

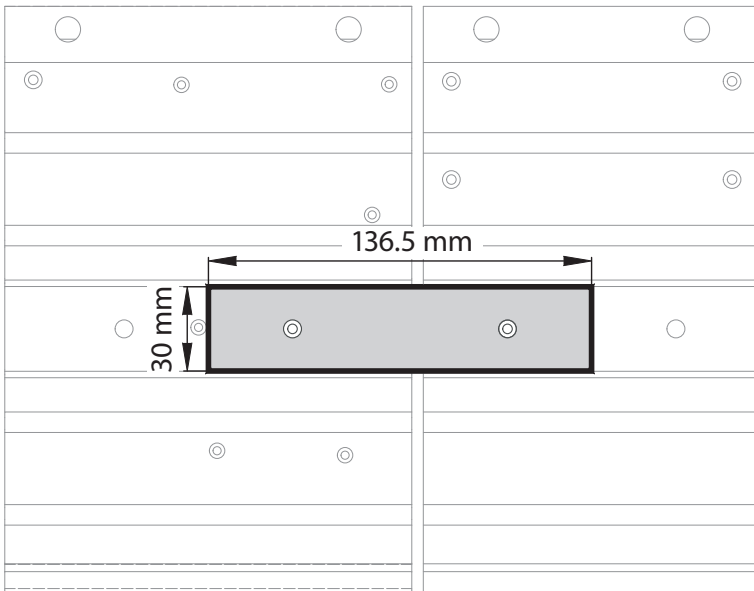

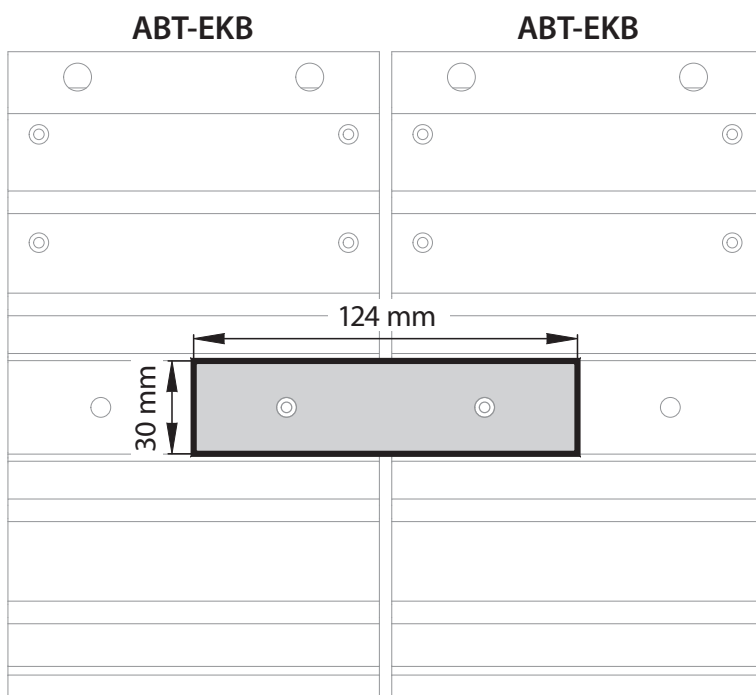

Drawing 68. Connection of microphone and extension using aluminium connectors

7.2.5 Noise sensing controller – ABT-NSC6

The background microphone controller is used to:

- » receive measured signals from 6 ABT-NSM microphones,
- » measure the background sound level and automatically adjust the emitted audio signal.



Drawing 69. ABT-NSC6 noise sensing controller

The ABT-NSC6 is a TCP / IP controller designed specifically for use with smartVES systems. The main role of the device is to collect audio data from 6 measurement microphones and automatically adjust the volume of background music and announcements in the assigned loudspeaker zones. The controller is suitable for use with ABT-NSM background microphones (in a loudspeaker enclosure).

Table 22. ABT-NSC6 technical data

Model	ABT-NSC6
Power supply	LAN PoE (RJ45) or via 2-pin 5.08 mm Phoenix connector
Number of audio inputs	6 differential channels, 3-pin connector type 15EDGVC-3.5
Power consumption (typical / maximum)	3.5 W / 6 W
Input voltage range	36 V – 57V
Sampling frequency	24 kHz
Frequency measurement band	200 Hz – 9 kHz @ 3 dB
Differential input impedance	6500 Ω @ 1 kHz
Range of measured values (for relevant input voltages)	57 dBs PL (250 μ V RMS) – 115 dB SPL (200 mV RMS)
Phantom power supply	30 VDC
Operating temperature range	-5°C to + 60°C
IP rating	54 // 66 - with additional sealing
Housing	Aluminium
Weight	1.2 kg

7.2.6 ABT-EOL end-of-line supervision module

ABT-EOL monitors the integrity of the loudspeaker line and all its branches. Monitoring of branch lines requires an EOL module for each branch. ABT-EOL provides a selective load for 20 kHz pilot tone only. The end-of-line module increases the reliability of the impedance-based loudspeaker supervision method. The module is connected in parallel to the last loudspeaker on the line. It has 4 different modes to be selected according to the results calculated by the EOL calculator.

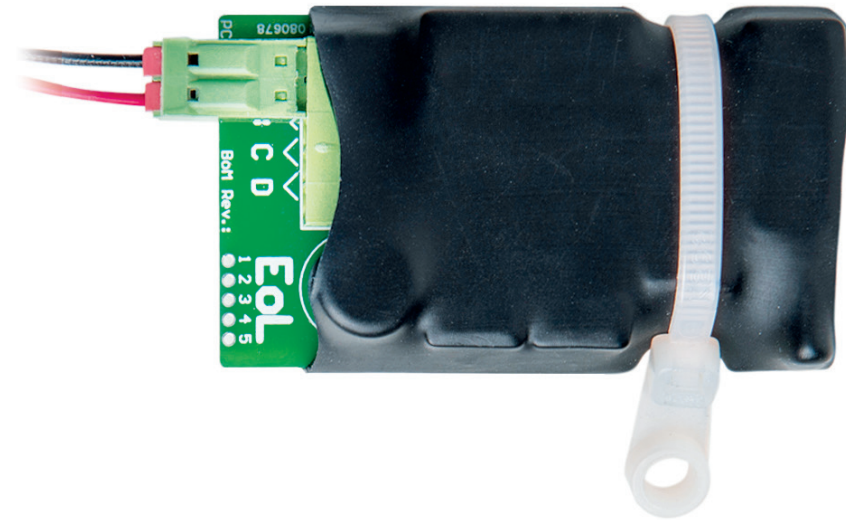

Drawing 70. ABT-EOL end-of-line supervision module

Table 23. ABT-EOL technical data

Model	ABT-EOL
Type	End-of-line module for loudspeaker lines
Connector	Phoenix 3.5 mm; 5 pins
Voltage	100 V loudspeaker line
Supported load	10 W – 480 W *
Operating temperature	-10°C to 55°C
Storage temperature	-40°C to 70°C
Relative humidity	< 95%
Dimensions	65 (L) × 16 (H) × 37 (W) mm
Installation	Inside the loudspeaker / optional installation box
Weight	approx. 46 g / set of 10 modules - 500 g

* Connection mode determined by the EOL calculator

8. System hardware installation

NOTE! The manufacturer reserves the right to make changes to specifications and operation without prior notice. Due to continuous modification and improvement, some of the functions described in this manual may differ slightly in reality.

Typically, the VAS unit is housed in a single cabinet or several connected cabinets, with up to 45U height for a maximum configuration. This depends on the size of the building and the complexity of the system. If several units are required to power a large number of loudspeakers serving a large multi-zone area, several subordinate units are required, another cabinet should be added. This will enable easier future expansion of the system.

The individual components must be tightened with sufficient force and care.

The arrangement of components in the cabinet depends on the complexity of the system. The following section of this manual contains requirements, guidelines and The following section of the manual contains requirements, guidelines and recommendations for the installation of the equipment. In the first stage, an empty space must be created for the batteries at the bottom of the enclosure.

This space should then be covered from the front with masking panels. The perforated panel is used to dissipate heat around the batteries.

Then insert the power supply manager and screw it firmly into the chassis frame. There should be a gap between the battery and the power manager, which will also be masked with a panel. This space is very important. The batteries will be inserted and connected as the last components of the VAS.

The next component to be inserted and bolted is the SMART-PF4 power supply frame, which holds up to four power supplies SMART-PS48800. Above the frame it is recommended to keep the space clear, minimum 1U, recommended is 2U.

The next components to be placed are the control units. Once they are seated in the cabinet, the following should be inserted: the function and control cards for the loudspeaker lines. This should be followed by a masking panel over the control unit, with a minimum height of 1U, the recommended value is 2U.

A later stage is the assembly of the amplifiers. Due to the significant weight of the amplifiers, structural components must be used in the rack to ensure adequate structural strength. As many as 3 amplifiers can be mounted on top of each other, after which a spacing of 2U must be maintained. Perforated panels are recommended to cover the free spaces. The amplifier with the spare channel should be seated uppermost. Above it, a space of at least 1U is required, the recommended value is 2U.

A ventilation panel is required, in the highest possible position of the rack, to ensure efficient heat dissipation.

8.1 Information on limiting damage consequences

To avoid problems with operating the Voice Alarm System Control Unit, it is recommended that you read the following written section of this manual before using the control unit.

The VAS control unit is equipped with a number of automatic functions to test the system's performance. It signals the detection of a malfunction with the Fault LED. You should react immediately to such a situation and, if necessary, consult the person responsible for the VAS performance.

8.2 General connection diagram

Network connection of remote central units and firefighter microphones via a fibre optic loop:

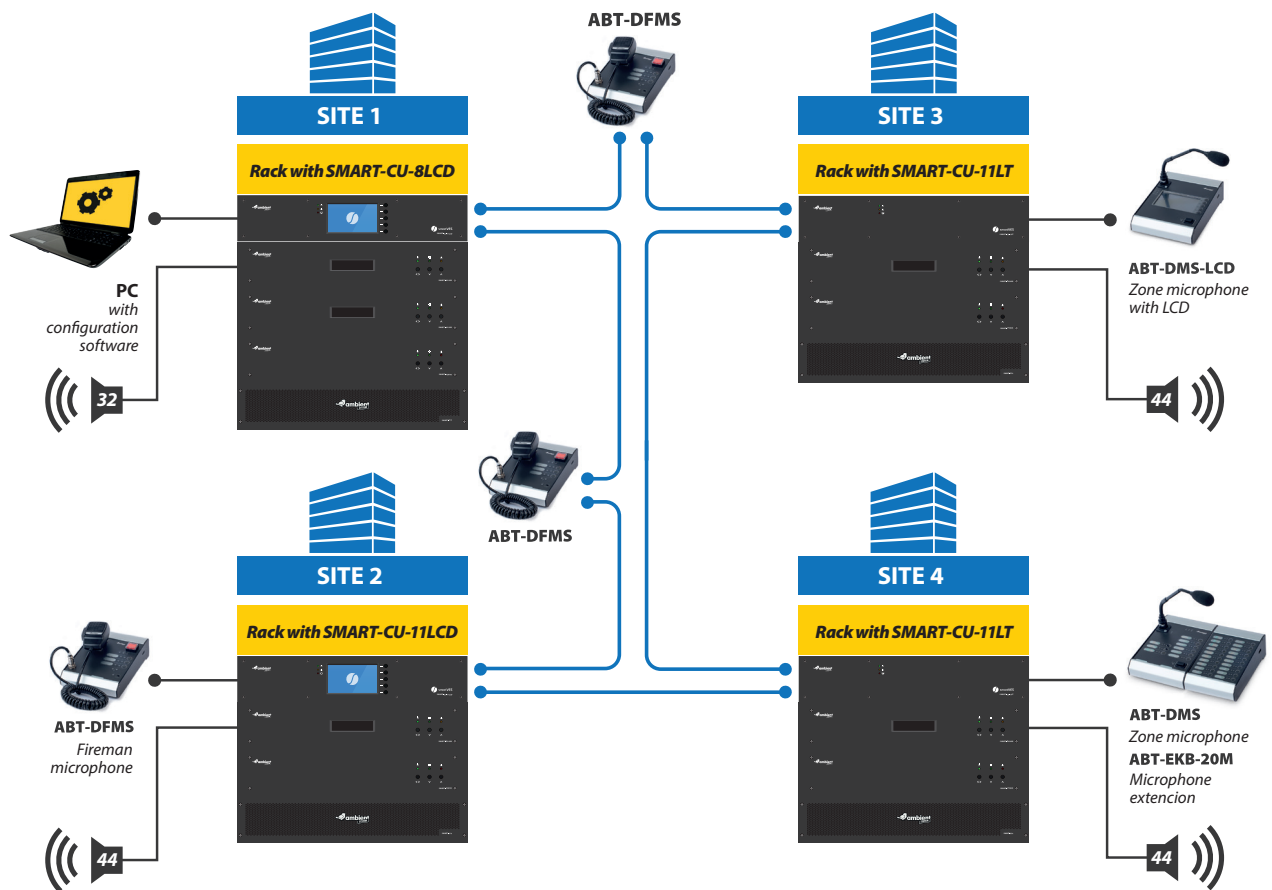

Drawing 71. General connection diagram

8.3 Connecting devices

The VAS control unit should be housed in an IP30-rated enclosure (according to EN 54-2) with supply ventilation.

In order to ensure the compliance of the DSO control unit with the standards, the connections:

- » with the fire alarm control panel (FACP),
- » power sources,
- » firefighter microphones,
- » network infrastructure,
- » other elements of the VAS control unit,

must be carried out by persons who are suitably trained and qualified in accordance with the provisions of the relevant directives for electrical equipment.

When installing the equipment in a RACK cabinet, the order (counting from the top) is recommended:

- » backup amplifiers,
- » amplifiers,
- » control units,
- » power supply units,
- » power supply manager,
- » batteries.

Once all the equipment is inside the rack, the next step to be taken is to connect the components with the power supply manager. This process is presented on page XXX.

⚠ NOTE: It is crucial to connect the batteries to the system before startup.

After connecting the power supply, connect the signal paths and audio paths. Then connect the speaker lines, logical inputs and outputs and network devices.

Once you have ensured that the required connections have been made correctly, you can proceed to switch on the power supply.

8.3.1 Diagram of smartVES devices

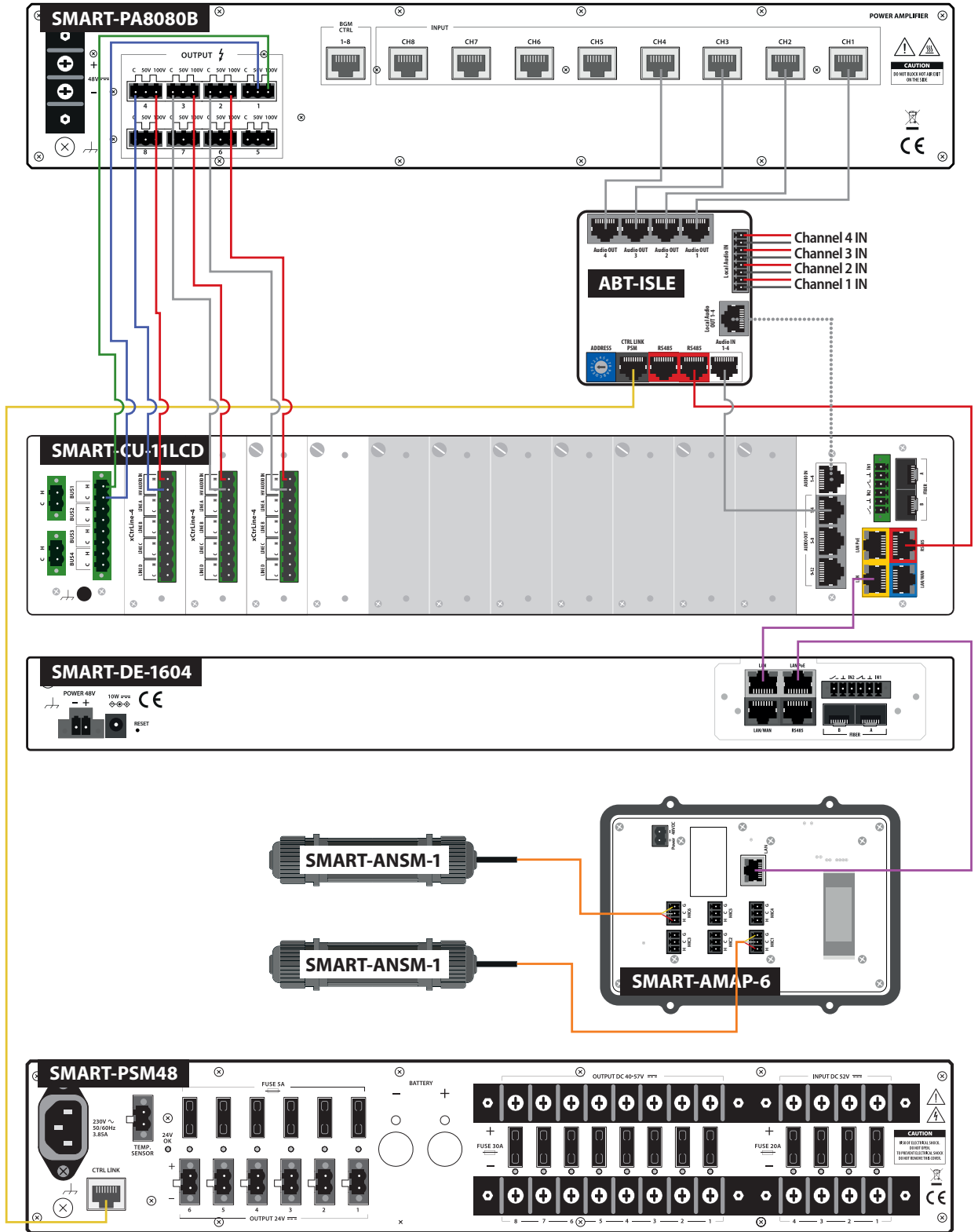

8.3.2 Control units

This section presents example wiring diagrams of control units.

8.3.2.1 Daisy chain Topology

In the daisy chain topology, the connection is not redundant. Connecting the units in this way does not guarantee correct operation of the system in the event of damage to the communication cable. According to the EN54-16 standard, the connections between the VAS control units in a distributed system must be redundant. Connections in the daisy chain topology are used the RACK cabinets, and in a system that is not designed for broadcasting evacuation messages.



Drawing 72. Example of connection of control units in daisy chain topology

8.3.2.2 Ring topology

In the Ring topology, the connection between system components is redundant. In the event of damage to the communication cable/fibre, the system remains functional using the remaining part of the ring.

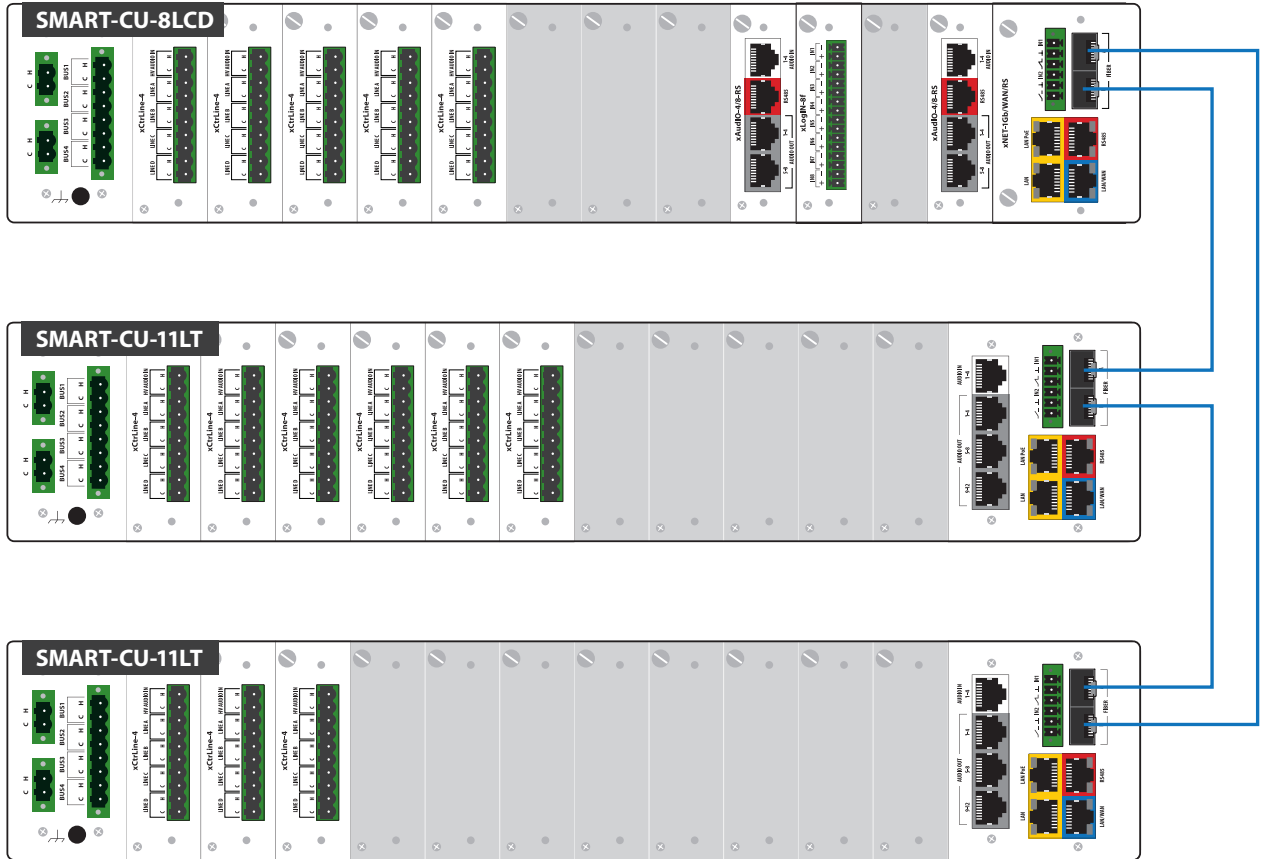

Drawing 73. Connection of control units in Ring topology (optical fibre)

8.3.3 Amplifiers

8.3.3.1 Individual connection without backup channel with SMART-CU-8LCD

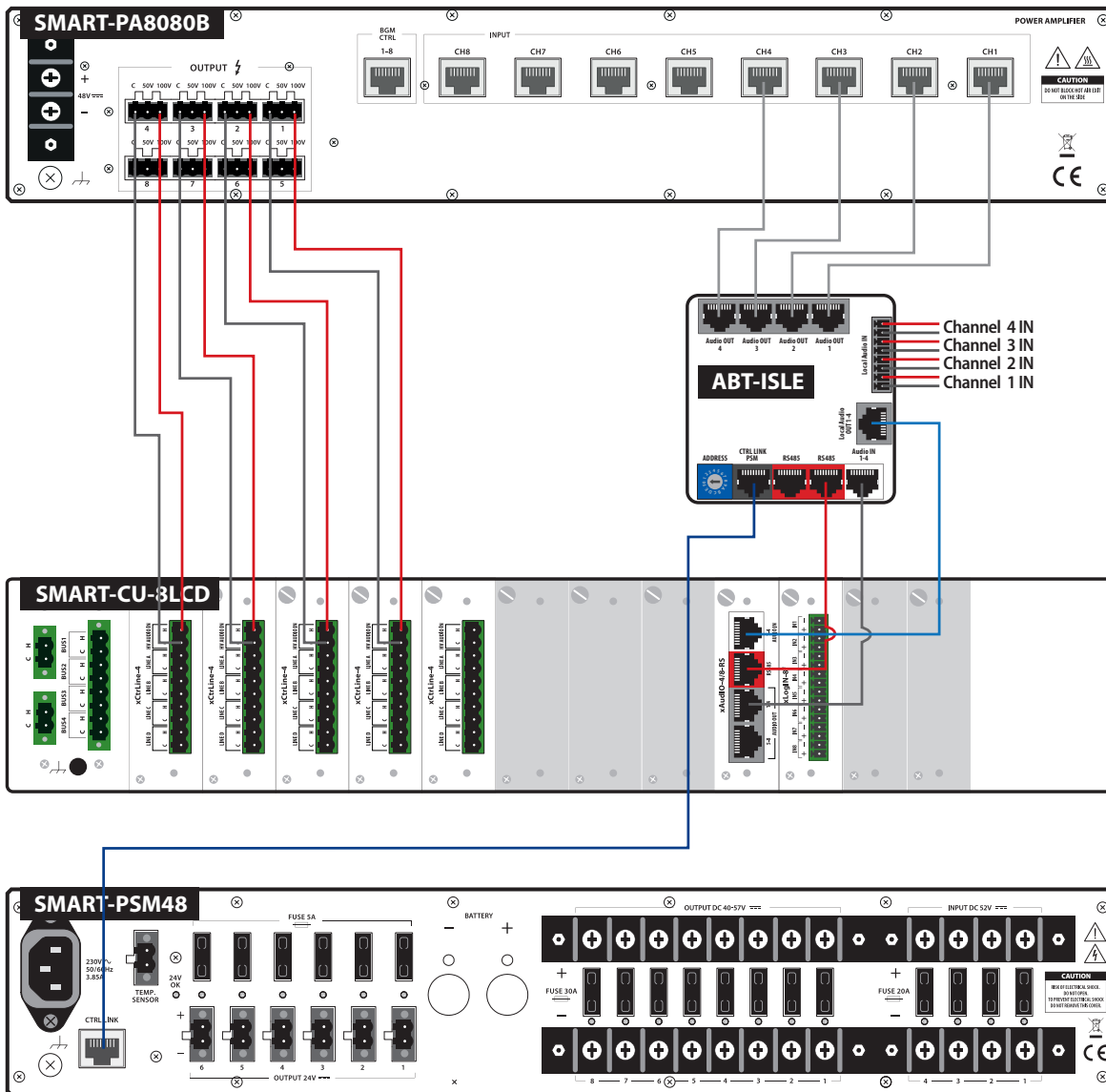

Drawing 74. Individual connection of amplifiers to the SMART-CU-8LCD unit

NOTE! All cables used to connect the RJ-45 connectors in ABT-ISLE must be of the T568B straight type standard. The use of cabling of a different standard (e.g. cross) may result in damage to system components.

8.3.3.2 Individual connection without backup channel with SMART-CU-11LT / SMART-CU-11LCD

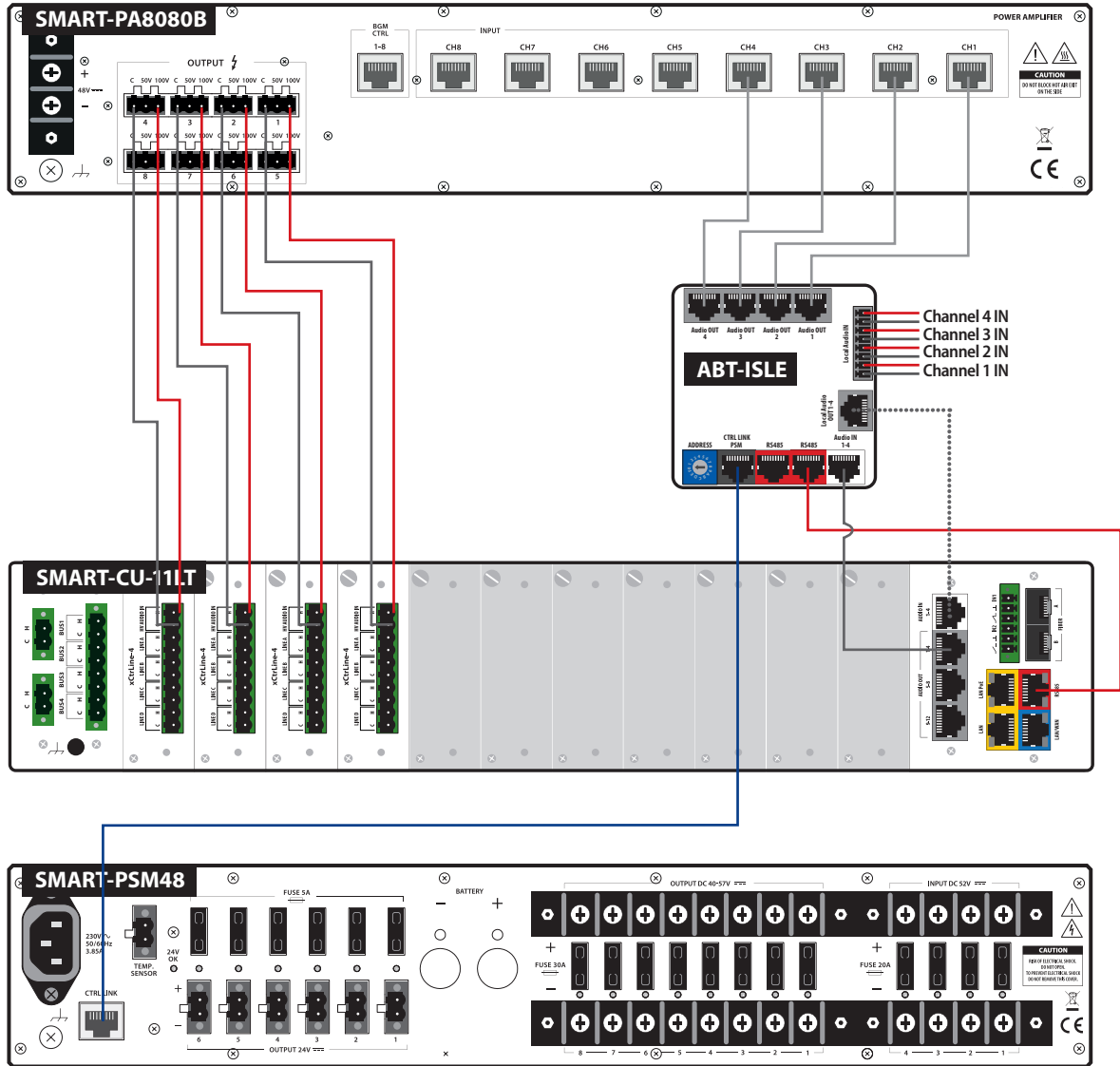

Drawing 75. Individual connection of amplifiers with SMART-11LT / SMART-11LCD unit

⚠ NOTE! All cables used to connect the RJ-45 connectors in ABT-ISLE must be of the T568B straight type standard. The use of cabling of a different standard (e.g. cross) may result in damage to system components.

8.3.3.3 Connection with 100 V internal buses for SMART-CU-8LCD

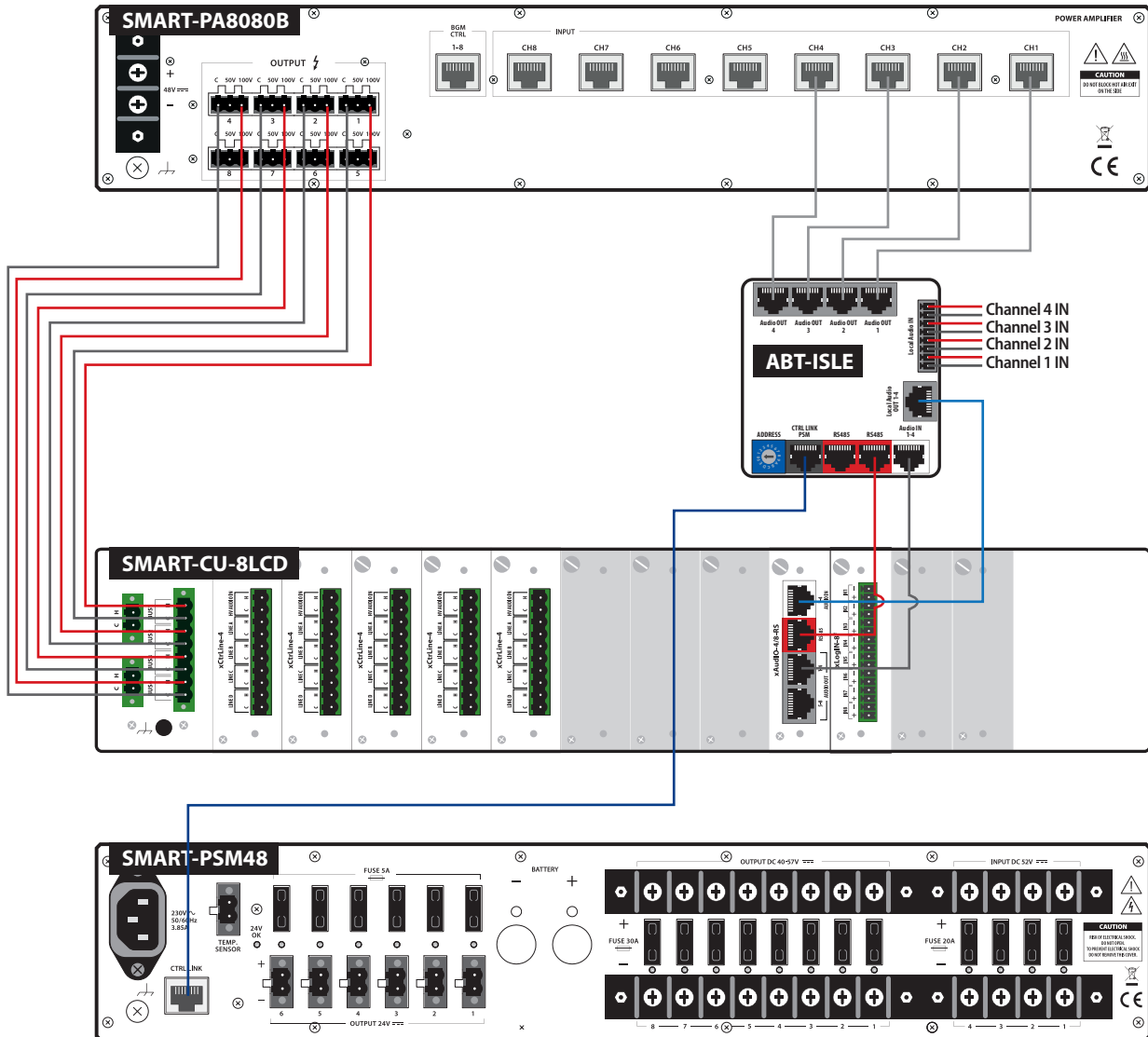

Drawing 76. Connection with redundant amplifier channels to the SMART-CU-8LCD unit

⚠ NOTE! All cables used to connect the RJ-45 connectors in ABT-ISLE must be of the T568B straight type standard. The use of cabling of a different standard (e.g. cross) may result in damage to system components.

8.3.3.4 Connection with 100 V internal buses for SMART-CU-11LCD / LT

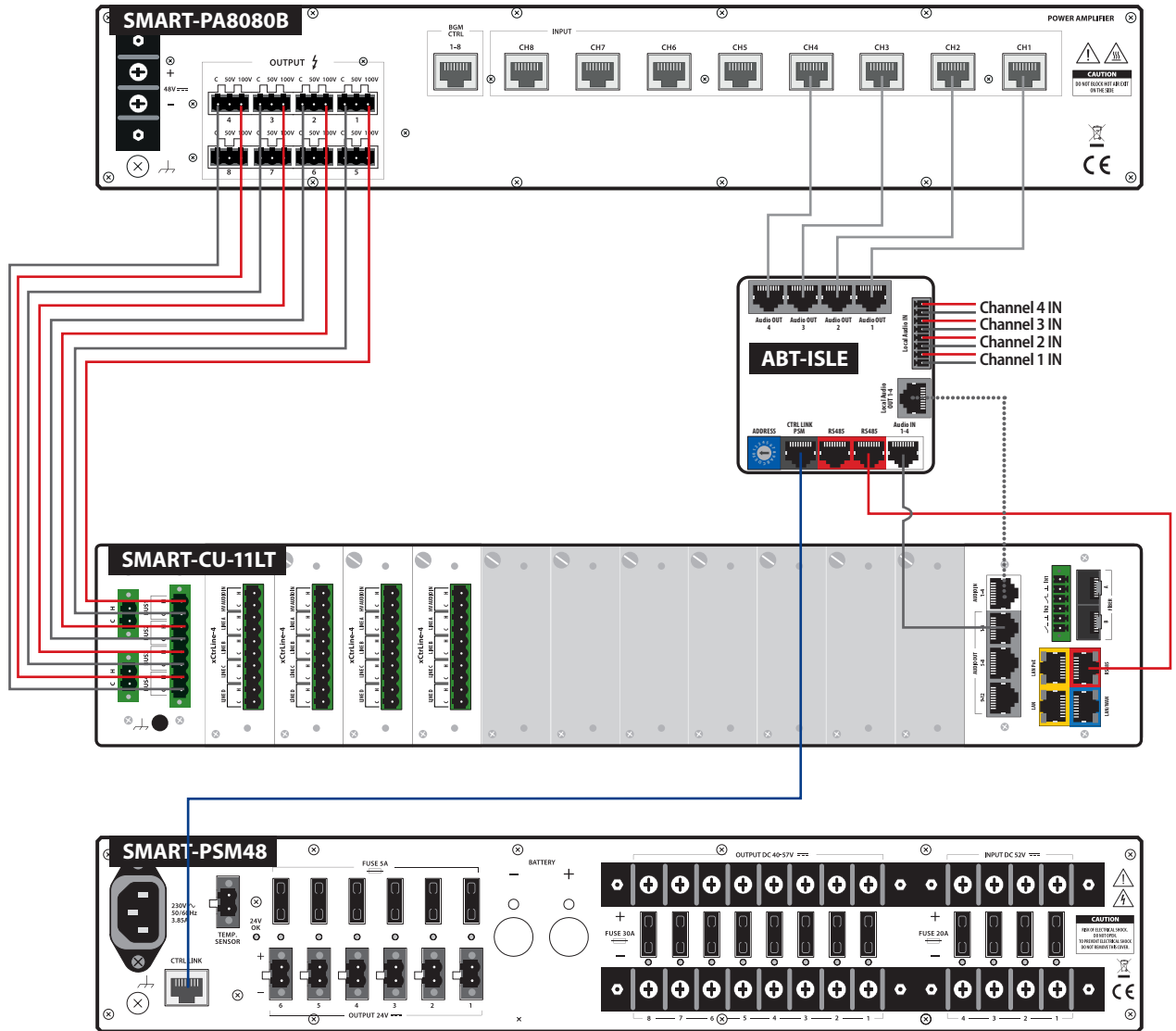

Drawing 77. Connection with redundant amplifier channels to the SMART-CU-11LT / SMART-CU-11LCD unit

⚠ NOTE! All cables used to connect the RJ-45 connectors in ABT-ISLE must be of the T568B straight type standard. The use of cabling of a different standard (e.g. cross) may result in damage to system components.

8.3.3.5 Individual connection with backup channel for SMART-CU-8LCD

Individual connection with back-up channel (1 to 4 back-up channels available).

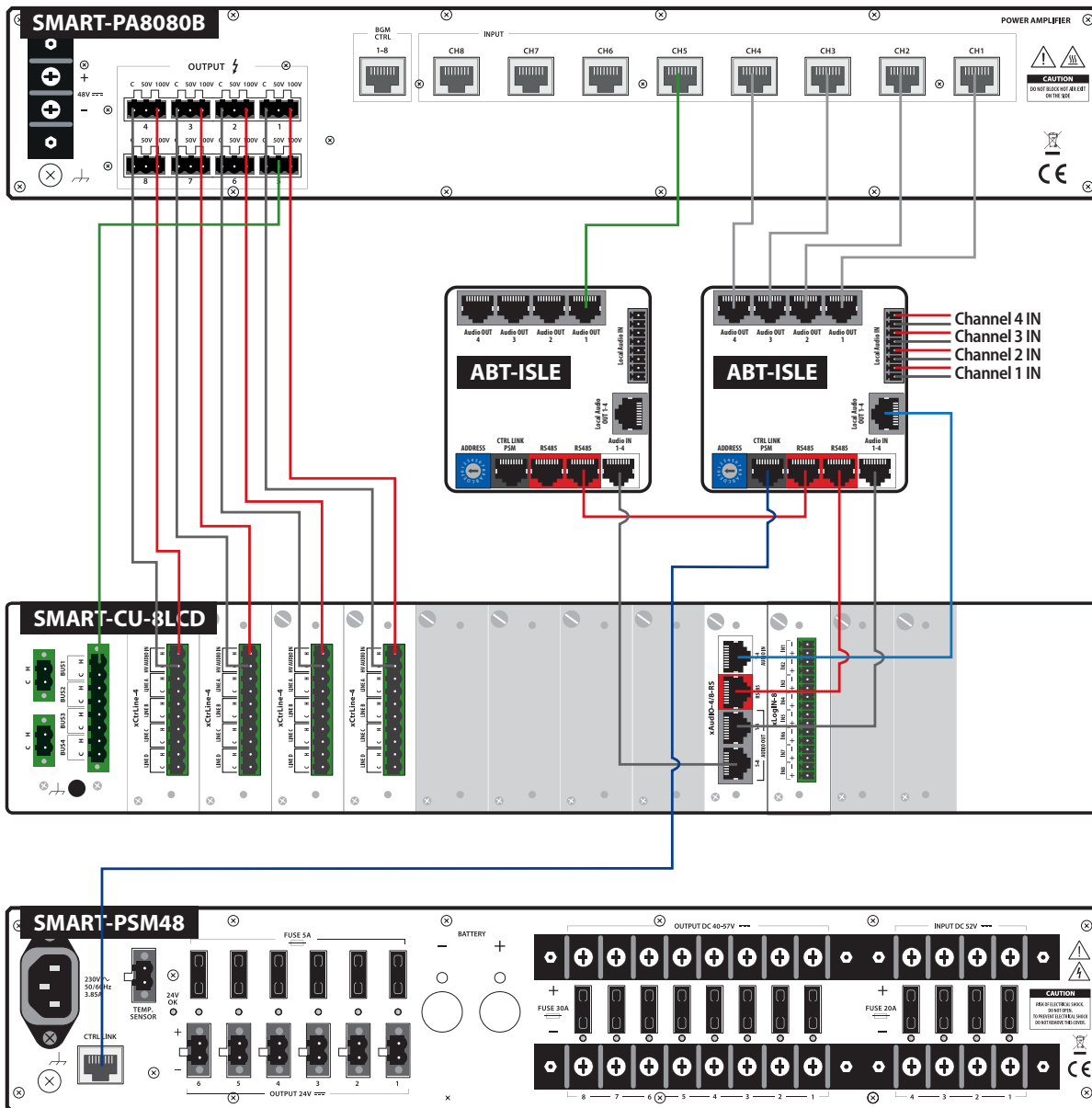

Drawing 78. Connecting a backup amplifier to the SMART-CU-8LCD unit

NOTE! All cables used to connect the RJ-45 connectors in ABT-ISLE must be of the T568B straight type standard. The use of cabling of a different standard (e.g. cross) may result in damage to system components.

8.3.3.6 Individual connection with backup channel for SMART-CU-11LT / SMART-CU-11LCD

Individual connection with back-up channel (1 to 4 back-up channels available).

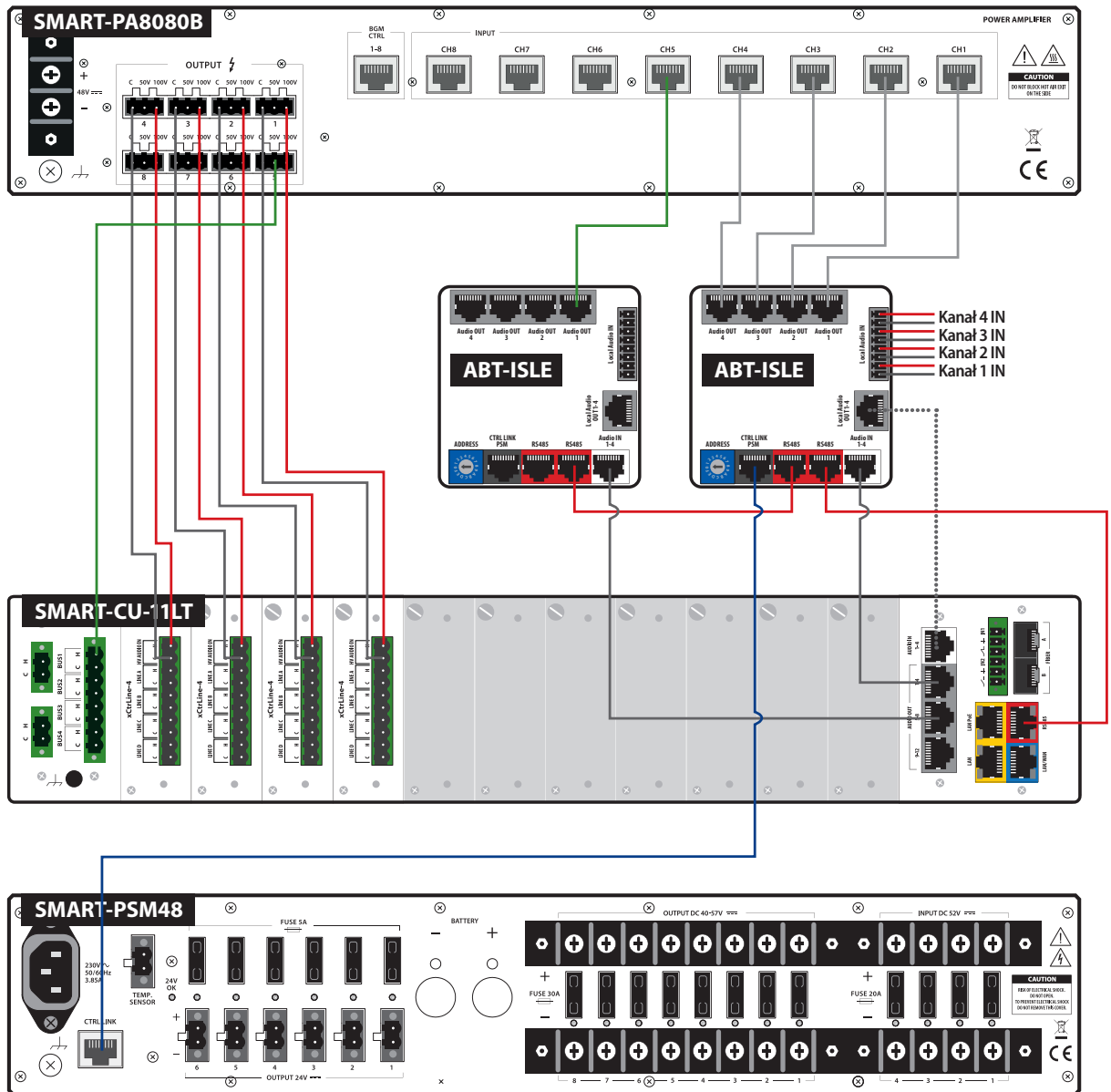

Drawing 79. Connection of a backup amplifier to the SMART-CU-11LT / SMART-CU-11LCD unit

⚠ NOTE! All cables used to connect the RJ-45 connectors in ABT-ISLE must be of the T568B straight type standard. The use of cabling of a different standard (e.g. cross) may result in damage to system components.

8.3.4 Power supply

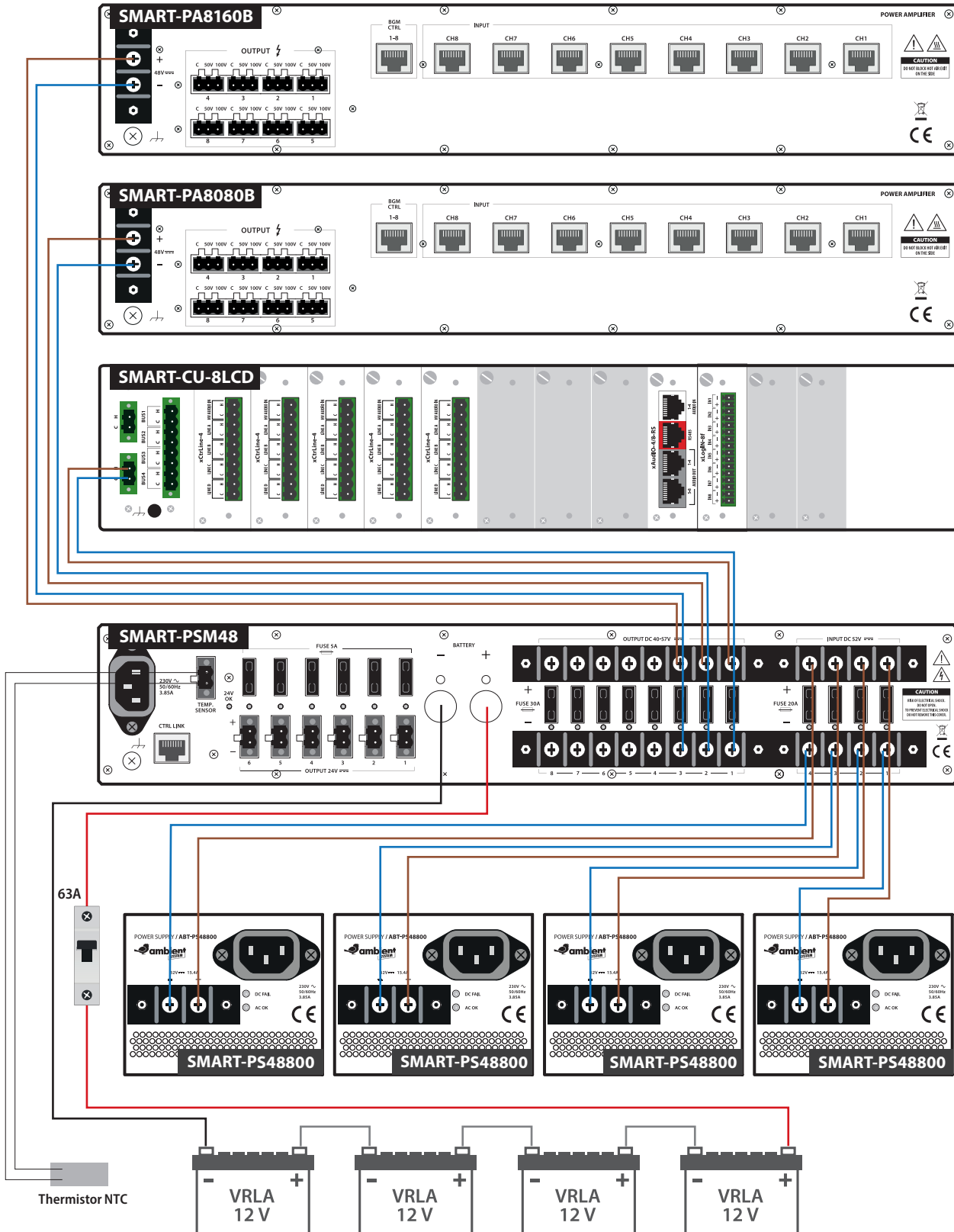

Drawing 80. Power supply diagram

8.3.4.1 Batteries

Special care must be taken to protect the batteries from short-circuiting when connecting the cables. The occurrence of a short circuit can lead to system failure. Follow these instructions to ensure safety when connecting.

Ensure that the power supply to the system is disconnected before connecting the batteries.

When you have finished connecting the batteries, make sure that the terminals of each battery are protected against the possibility of a short circuit.

Principles of battery selection:

When selecting batteries, check that they belong to the same product series and are from the same lot. This will prevent excessive ageing of the batteries.

The preferred type of battery is SLA (Sealed Lead-Acid).

In order for the system to operate correctly, four batteries must be connected, resulting in an output voltage of 48VDC.

Preparing the cable termination:

To ensure proper connections between the battery terminals and the cables, make sure you use a cable with the correct diameter and prepare its termination as below.

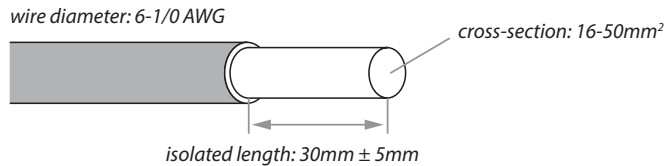

Drawing 81. Preparing the cable termination

Notes on connecting cables to battery terminals

- » Before connecting the cable to the battery terminal, ensure that it is fully open by removing the terminal screw.

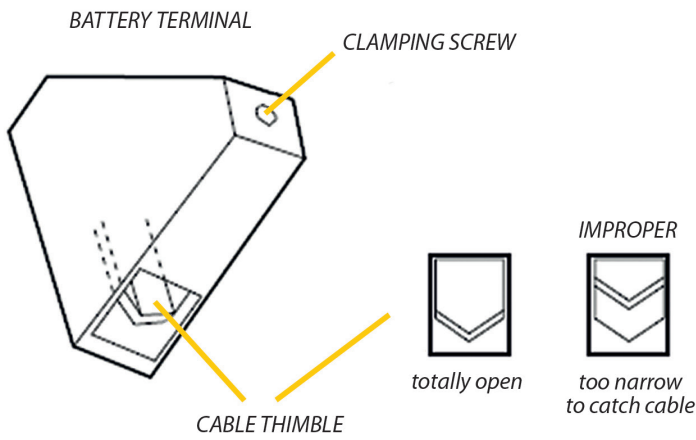

Drawing 82. Completely open terminal of the Power Supply Manager

- » Slide the battery cable into the correct position in the terminal, as shown in the following diagrams.

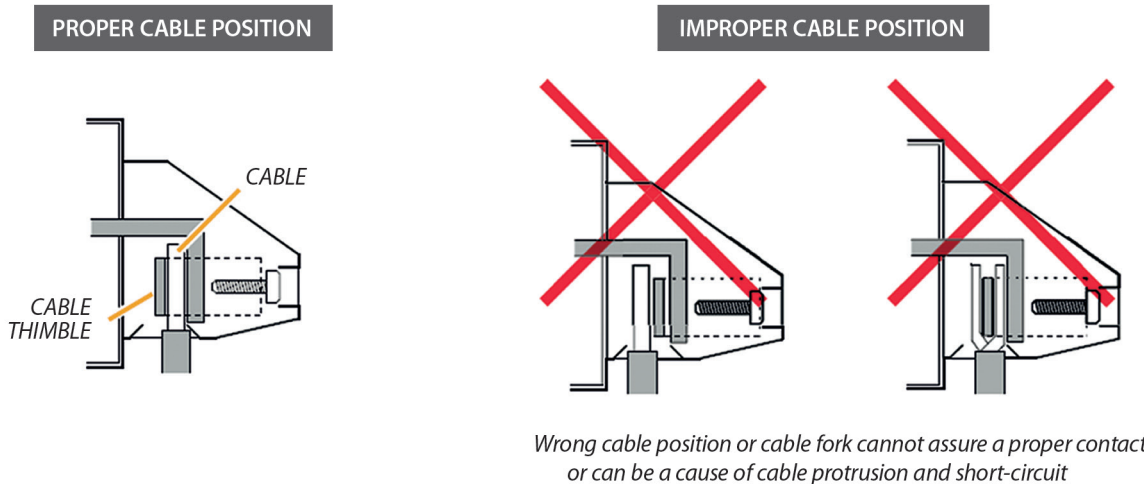

Drawing 83. Proper cable position

- » Strip a length of cable sufficient to ensure full contact. Otherwise, when leaving the insulation, the contact will be incomplete

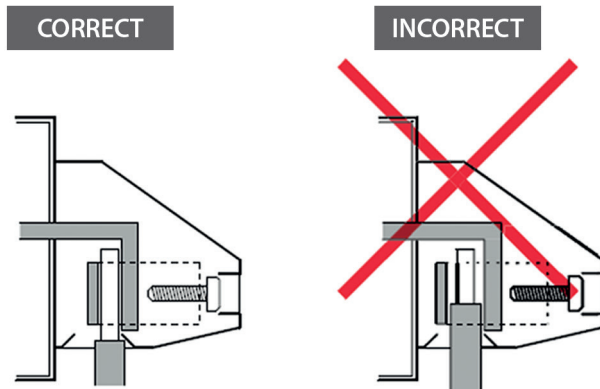

Drawing 84. Correct connection of storage battery cables

Connecting batteries

- » Wait more than 10 seconds after removing the power cable from the AC socket mounted on the rear panel of the SMART-PSM48.
- » Insert the cable into the battery terminal and secure it by tightening the screw with a flathead screwdriver. Never connect the negative cable first, so that in the event of a short circuit between the positive cable of the battery and the frame of any equipment or rack component, the equipment will not be damaged.
- » Connect the negative battery cable to the negative terminal.

Disconnecting batteries

- » Ensure that battery power is not in use by checking that the LED on the front panel of the SMART-PSM48 is not illuminated.
- » Unscrew the negative terminal of the SMART-PSM48 battery power input and remove the negative battery cable from the terminals. Never disconnect the positive lead first to avoid short-circuiting by touching the unit frame or rack component. Insulate the disconnected cable end with a suitable insulator, such as insulating tape, to prevent a short circuit.
- » Disconnect the positive battery cable. Insulate the disconnected cable end with a suitable insulator, e.g. insulating tape, to protect against a short circuit.

- ⚠ The total voltage of the batteries, connected to the device, for charging and monitoring, complying with EN 54-4, should be 48 V DC (40-56 V DC). In the final step, connect the four 12 V VRLA batteries to the pair of battery terminals located on the rear panel of the SMART-PSM48 manager, paying attention to the polarity of the wires. In addition, connect the thermistor temperature sensor by attaching its cable to the Temp Sensor connector and locating the sensor where the batteries are installed.

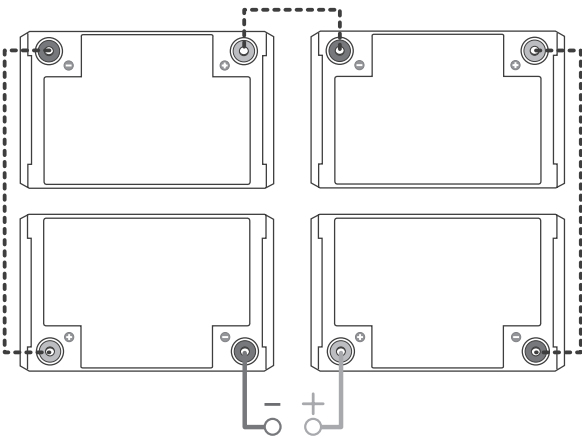

Drawing 85. Interconnection diagram for 4x12 V DC VRLA batteries

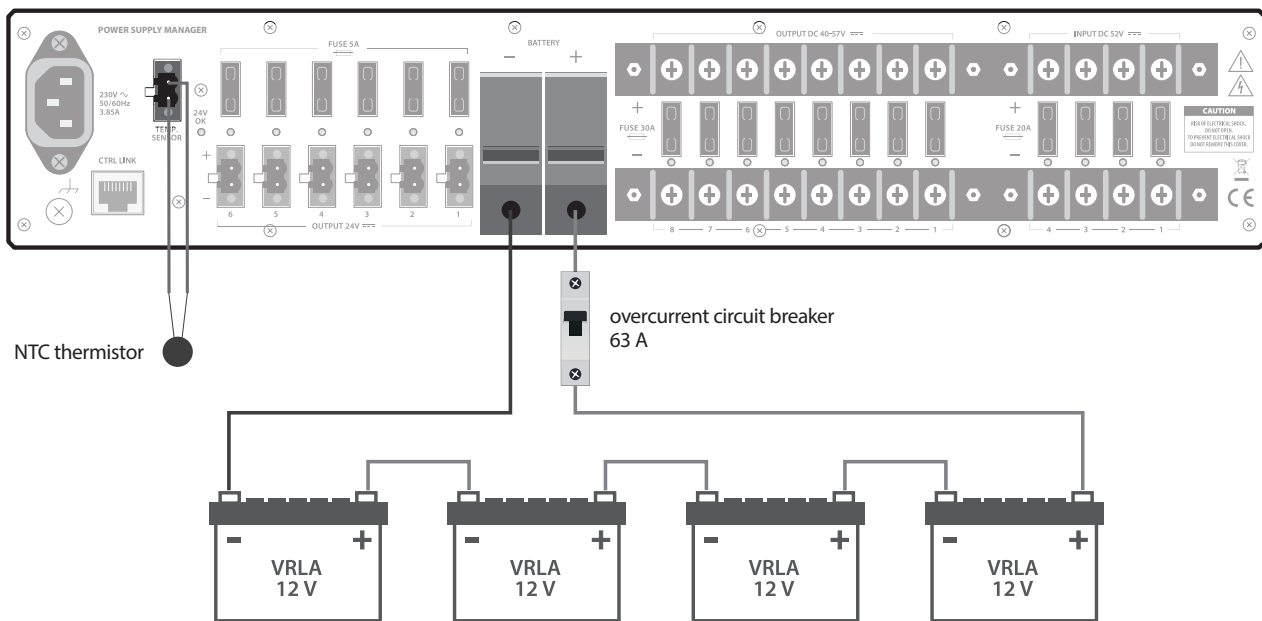

Drawing 86. Connecting the battery bank to the power manager

For the battery bank circuit, use: 2 × 63 A fuse, DIN rail ø15 mm, øA 15.9 mm L=36 mm (positive and negative cable).

Thermistor installation:

The SMART-PSM48 rear-panel-mounted thermistor is designed to compensate for temperature variations when charging the batteries. Place the thermistor between the two batteries.

▲ NOTE: the thermistor cable can be extended by several metres without causing problems.

The smartVES control unit is supplied in a 19" rack with IP30 protection. The cabinet has a control door on both sides with security lock for access levels 2, 3 and 4.

Before connecting the power supply to the smartVES control unit, perform the standard checks described in section: Maintenance and service on page 135.

8.3.5 Microphones

8.3.5.1 Ring-type optical fibre connection for firefighter's microphone

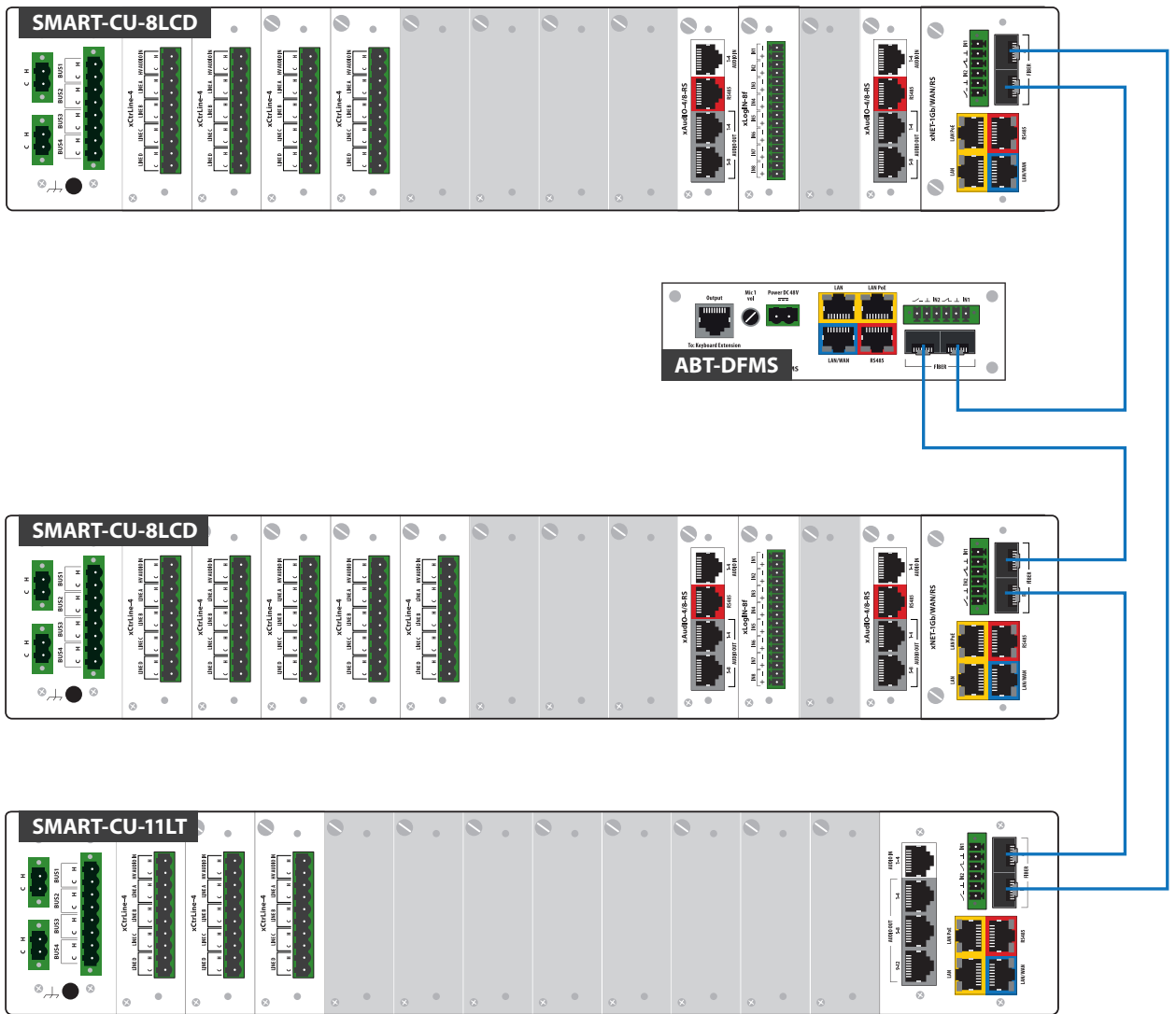

Drawing 87. Ring-type optical fibre connection for firefighter's microphone

8.3.5.2 Daisy chain cable connection for firefighter's microphone

In a daisy chain cable connection, the first firefighter microphone can be connected to the control unit via LAN PoE, while the subsequent microphones require an external power supply. The exception to this is a system where between the microphones there are PoE switches (the switches must be powered from the firefighter power supplies).

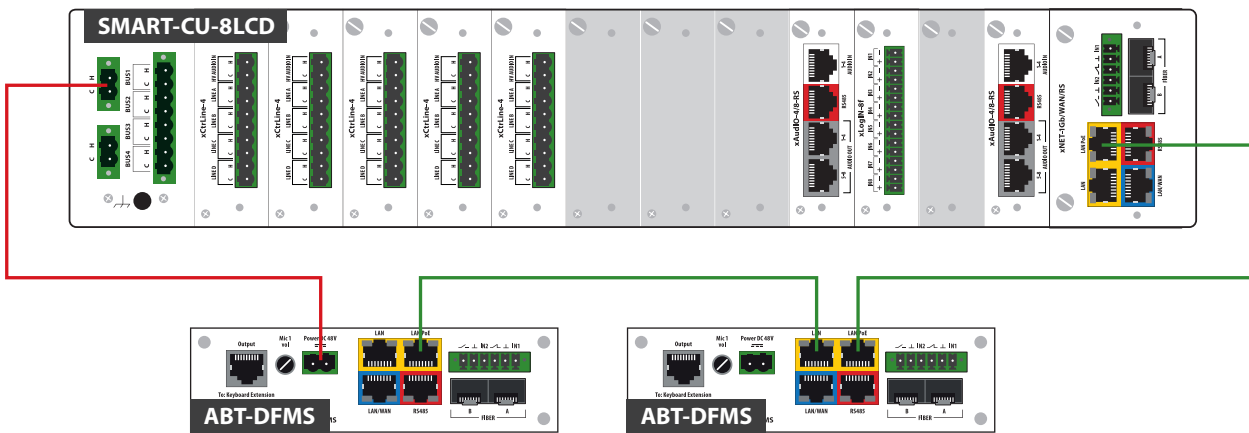

Drawing 88. Fireman's microphone cable connection - daisy chain topology

8.3.5.3 Fireman's and zone microphone cable connection using the LAN/WAN port on the front panel

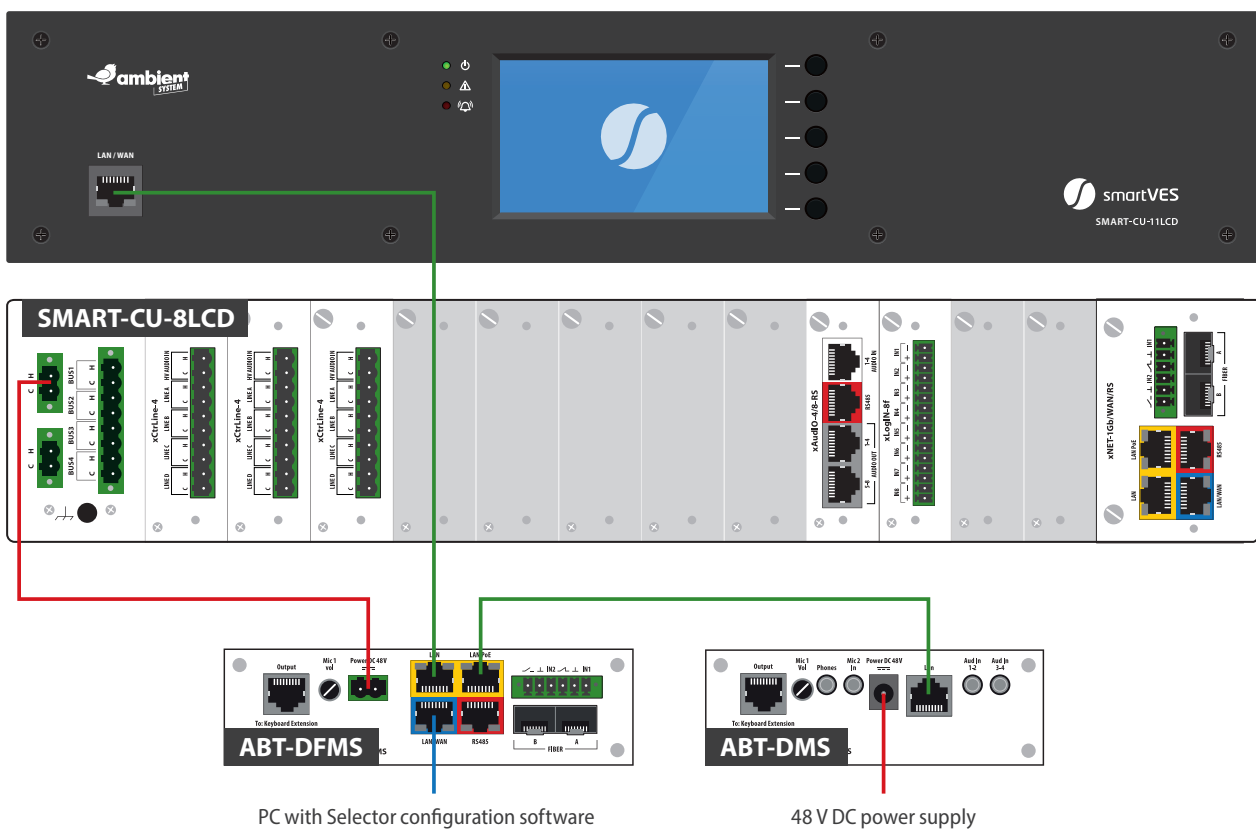

Drawing 89. Fireman's and zone microphone cable connection using the LAN/WAN port on the front panel

8.3.5.4 Power supply for the fireman's microphone

1. Using LAN PoE in SMART-CU-xx Control Units

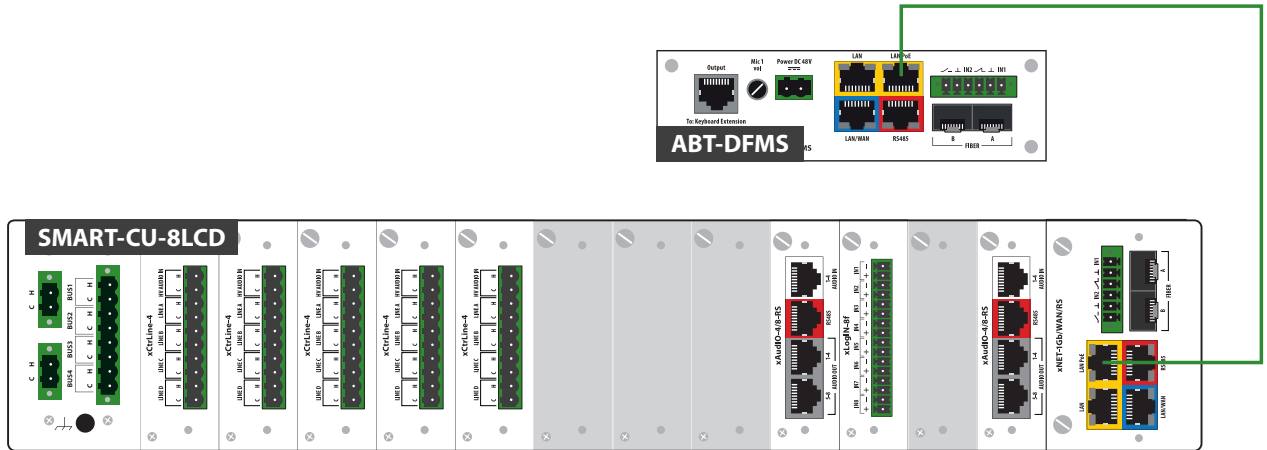

Drawing 90. Power supply for the fireman's microphone - LAN PoE

2. Using the power socket in the SMART-CU-xx Control Units, or in the SMART-PSM48 Power Manager

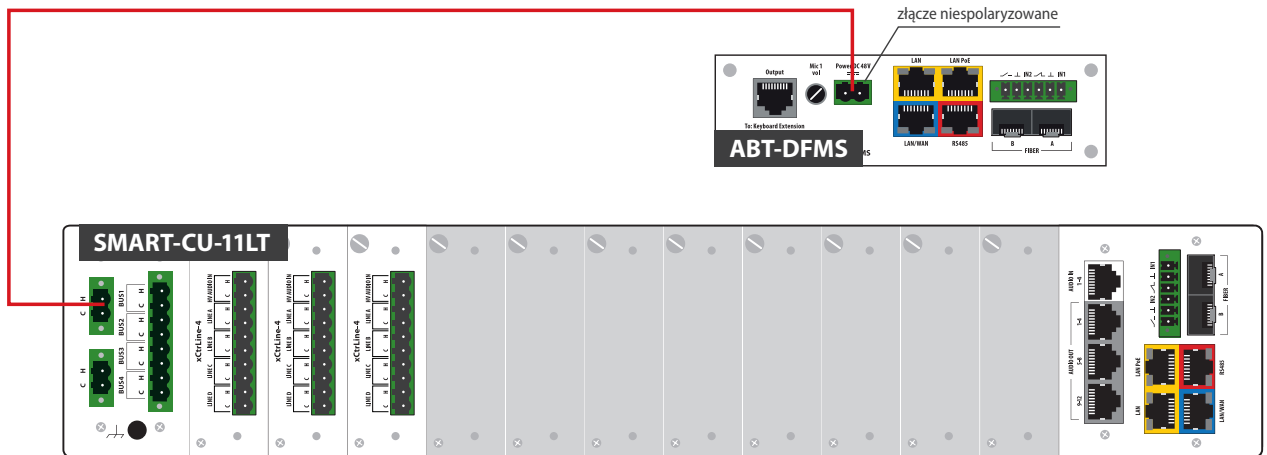

Drawing 91. Power supply for the fireman's microphone - power output

3. Using an external 48 V power supply unit

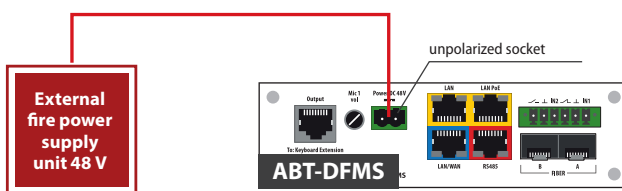

Drawing 92. Power supply for the firefighter's microphone - fire power supply unit

8.3.5.5 Zone microphones - connection types

The zone microphone can be connected directly to the VASCU via LAN, or to a fireman's microphone. More zone microphones can be connected to the VASCU using a certified switch. If the switch supports PoE, only one cable (UTP/STP cat. 5e) is required for the microphones to operate correctly.

1. **LAN PoE connection.** When connecting directly to the VASCU, no additional power supply is required, provided the unit has a LAN PoE port.

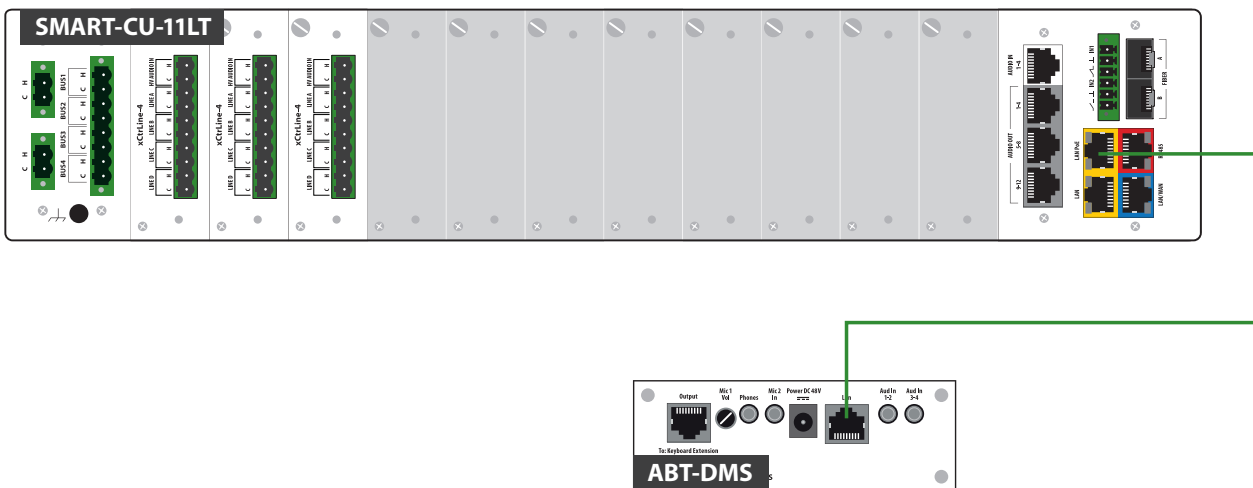

Drawing 93. Zone microphone connection

2. **Connection through the ABT-DFMS fireman's microphone.** In this case, additional power is required from an external power supply or from the SMART-PSM48 power manager.

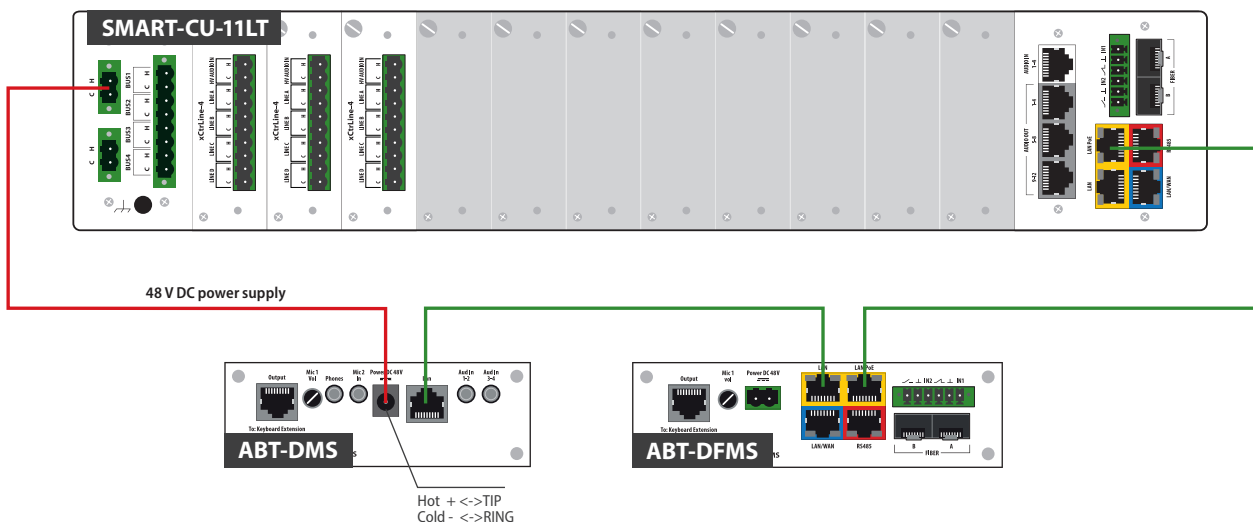

Drawing 94. Connection between zone microphone and fireman's microphone

3. **Connection using a certified network switch.** The following diagrams show connection of 4 zone microphones via a switch with LAN PoE.

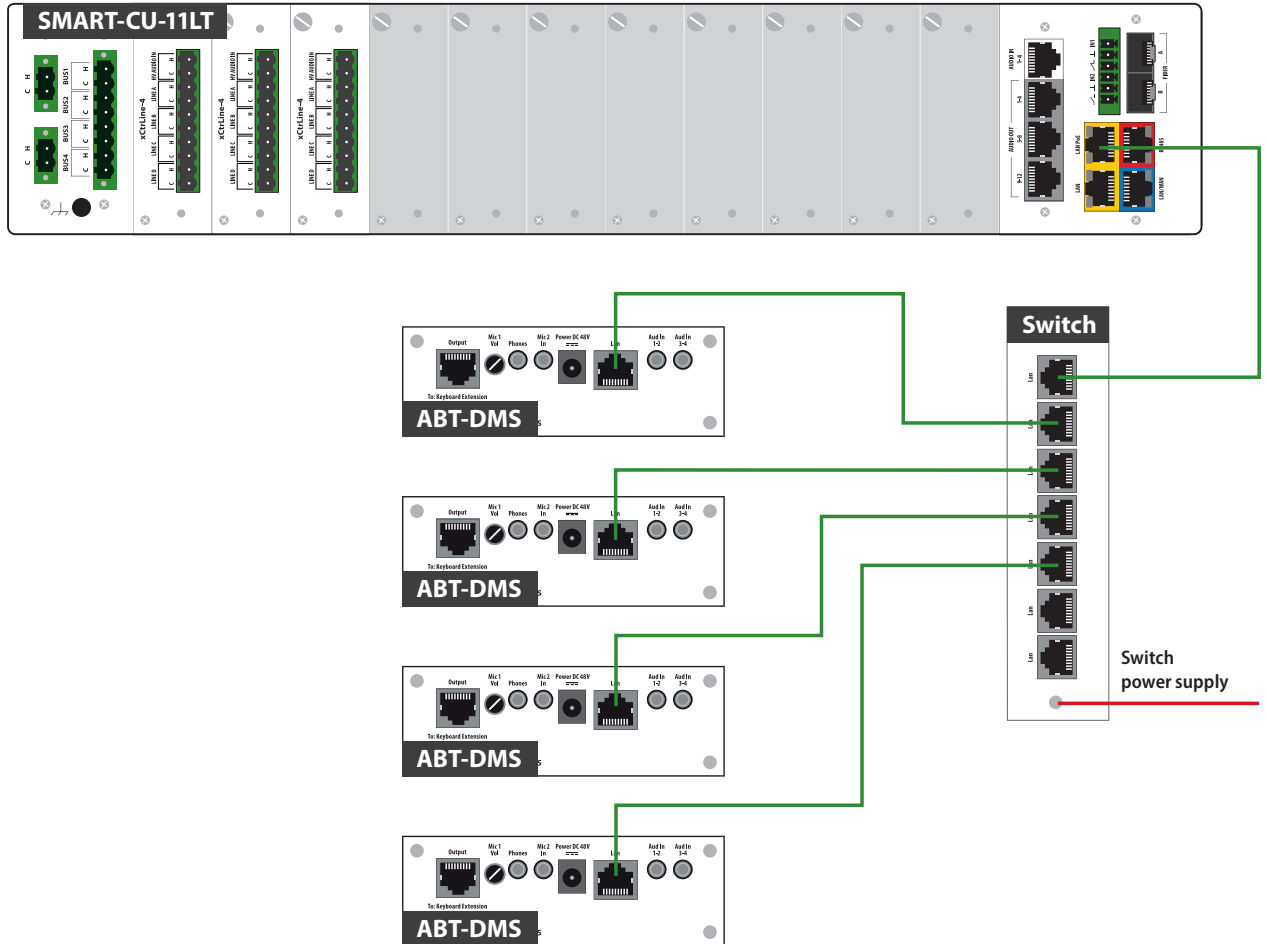

Drawing 95. Zone microphone - switch connection

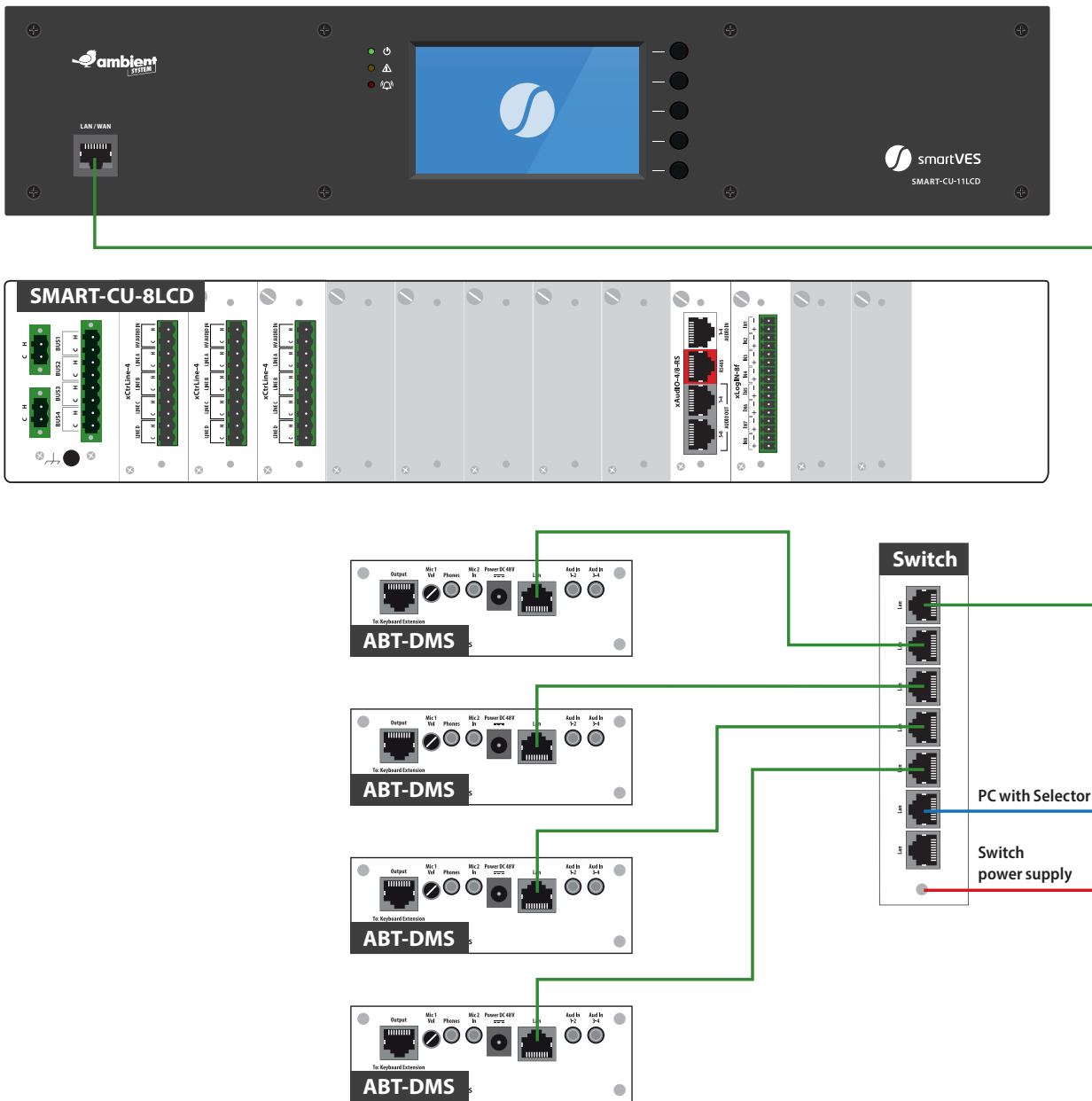

Drawing 96. Zone microphone connection - switch (connected to SMART-CU-8LCD front panel)

List of certified switches:

- » NETGEAR - Prosafe Gigabit Plus Series with PoE
- » CTC Union Technologies - IGS Gigabit Ethernet Managed Switch Series
- » CTC Union Technologies - IFS Fast Ethernet Managed Switch Series

8.3.5.6 Power supply for zone microphones

The power supply for the zone microphones is local (48 V) or from the VASCU using PoE.

Zone microphone power supply:

- Using LAN PoE (from VASCU or certified switch)

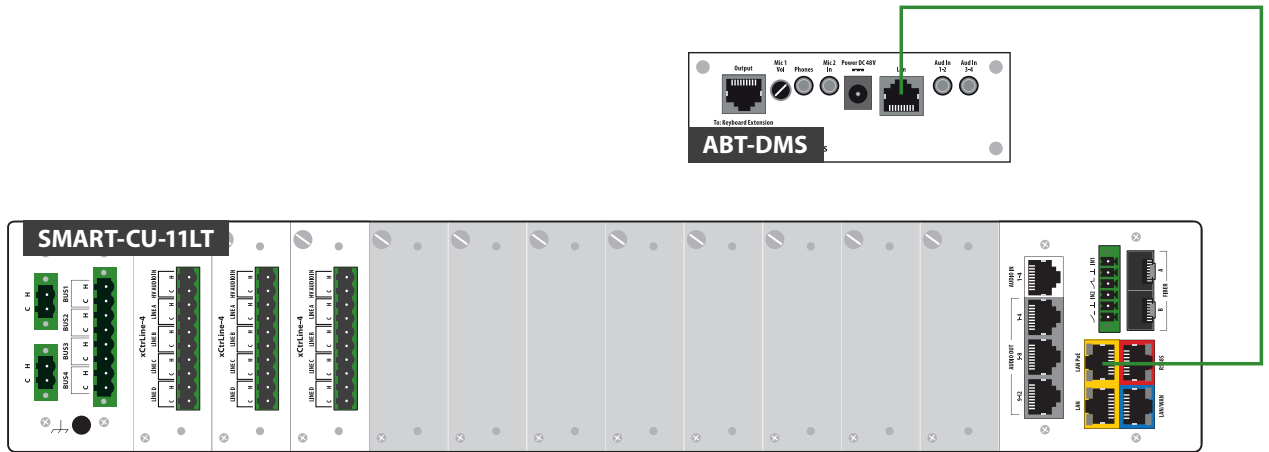

Drawing 97. Power supply for zone microphone - LAN PoE

- Using the power supply output of SMART-CU-XX Control Units

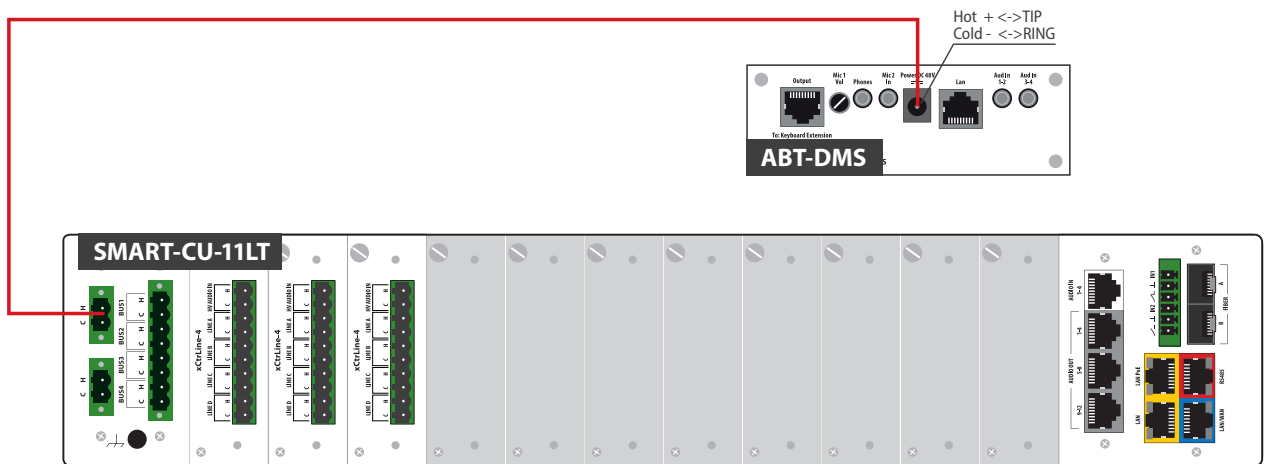

Drawing 98. Zone microphone power supply - power supply output of the control unit

3. Using the power output in the SMART-PSM48 Power Supply Manager

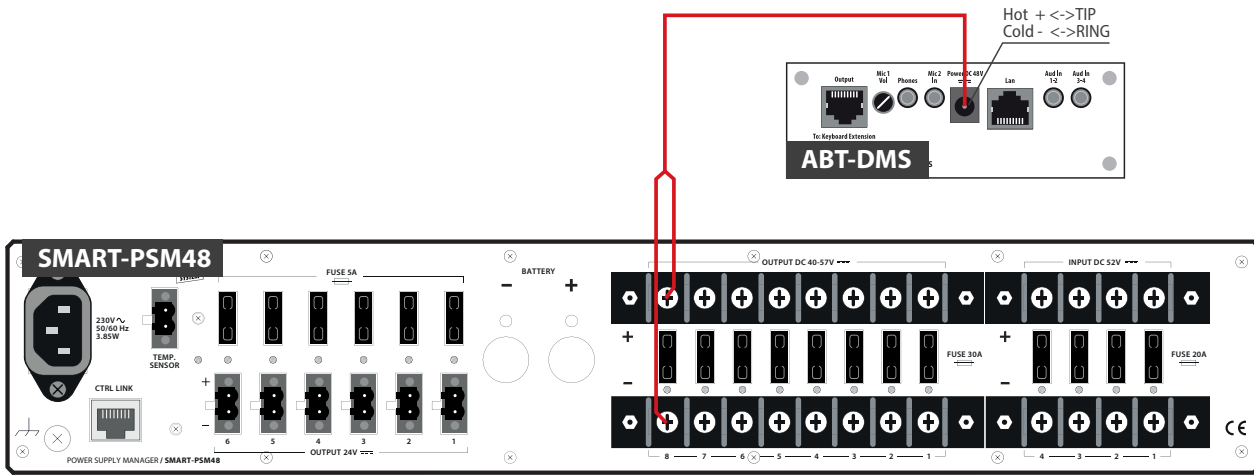

Drawing 99. Zone microphone power supply - power supply manager output

4. Using external 48V power supply

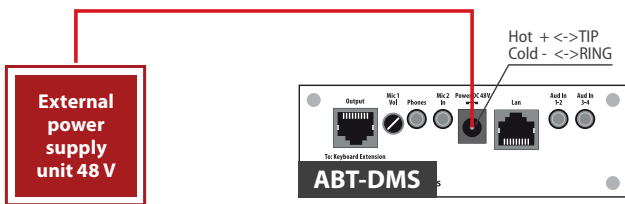

Drawing 100. Power supply for zone microphone - external power supply

8.4 Preparing the installation for VAS commissioning

Cabinet assembly

Loudspeaker line cables, control cables with FACIE and feeder cable – mark, take to target area of VAS sound system cabinet assembly with at least 3 meters of margin – counting from the floor. Anticipate empty service space behind the cabinet (at least 50 cm from the wall). Make sure there is a gap between the back of the cabinet and the wall.

Messages stored in the system memory

Specify the content, language and type of recorded messages. Alarm messages should be appropriate for the building and approved by the Fire Officer. For recorded messages, please consult with an employee of Ambient System Sp. z o.o. responsible for the implementation of the VAS start-up.

Emergency messages:

- » **EVACUATION** – potential life hazard requiring evacuation – message requires to leave the building immediately,
- » **WARNING** – situation in which danger is close and requires warning during evacuation,
- » **CANCELLATION** – information that the alarm has been cancelled and there is no danger on the site,
- » **NO HAZARDS** – operational messages, e.g. system testing,

Fire scenario and control between FACIE and VAS

Please prepare fire scenario which makes allowances for algorithm of cooperation between SAP and VAS systems. (This algorithm should be accepted by the Fire Marshal). Make sure that between the FACIE fire signaling central unit and VAS cabinet there are cable connections with regard to the number of controls allowing evacuation message and information on VSA system damage message. Control cables from FACIE central unit to VAS must be at least PH30. As for control algorithm, please consult Ambient System Sp. z o.o. employee responsible for VAS start-up.

Loudspeaker lines

Please check if loudspeaker lines have been made in accordance with the design (number of loudspeakers on line, speaker powers- if there are suitable taps on output transformers, if line descriptions are made properly – as required by the design). Use the meter (e.g. ohmmeter or multimeter) if there are any short-circuits between loudspeaker line and earthed element. Next, check for short-circuits or open-circuits between loudspeaker line wires.

⚠ While assembling loudspeakers, power taps must be properly positioned on transformers, as specified in the design. Unsuitable power setting can lead to amplifier tip overload. In the process of system startup, it causes unwanted time and energy loss.

Power supply

1-phase power supply 230 V. RACK cabinets with wires for VAS devices are prepared for connecting 1-phase power supply 230 V. A single cabinet is equipped with an overcurrent “S”-type single-phase switch. While supplying power, make sure each RACK cabinet is provided with a separate circuit, and choose a proper protection.

3x2,5 cable responsible for supplying the cabinet must be connected before the plant power supply main switch (to supply, use inflammable wire with PH90 coefficient). The power cord must be led to the target place where VAS cabinet is assembled. The cabinet power supply circuit must be protected with a residual current device.

System start-up by employees of Ambient System Sp. z o.o.

Start of the DSO system can be commissioned to employees of the Ambient System Sp. z o.o.

To do this, contact the Sales Representative who finalized the sale of the system and make trade arrangements or report to the technical support line number (+48 601 649 484).

Prepare the sound system in accordance with the guidelines above. Make sure assemblers have access to the room intended for VAS cabinets, reduce the number of third parties at the time when the system is installed. It is strictly forbidden to perform any works in the VAS assembly room by workers unauthorized to install VAS cabinet. Once the system has been started, conduct a training related to system operation for persons responsible for proper system use, and prepare relevant protocols.

Speech transmission index test

Pursuant to provisions of EN 60849 norm, each Voice Alarm System (VAS) installation must be followed by STI tests. These tests aim to confirm that the installed sound devices are able to produce a suitable acoustic power which allows obtaining a required sound pressure level (SPL), as well as a high degree of speech intelligibility – in accordance with assumptions in the specification. The tests must be performed when the system operates in the alarm mode and does not use dynamic range compressors.

The date of testing must be arranged with a person responsible for administration of the building and Ambient System Sp. z o.o. employee. Make sure to provide access to rooms in which tests are supposed to be carried out (as a rule – all rooms in the building). Please notify persons staying in the building (i.e. plant administrator) that tests will entail unpleasant and noisy signals emitted by loudspeakers.

9. Operation modes – LED colors

LED indicators located on microphones and control units can signal various statuses. The tables below present the indicators and their functions.

Table 24. Colors signaling on the system microphones depending on the function assigned





FUNCTION	GREEN		RGB			Blink	On
	Blink	On	R	G	B		
General	✓						
Stop Scenario	✓						
Skip Scenarios Delay	✓						
Audio Monitor	✓	✓					
Volume Change	✓						
Failure Accept	✓						
Failure Delete	✓						
Alarm Mode	✓	✓	●				
Display Text	✓						
Led Test							
Select Audio Source	✓	✓					
Mute Audio Source	✓	✓					
Select Zone	✓	✓					
Block Zone	✓	✓					
Zone(s) OFF	✓						
Group Zone	✓	✓					
Start/Stop Matricing	✓	✓					
Power Safe	✓	✓		●	●		
Scenario Delay	✓		●		●	✓	

FUNCTION	GREEN		RGB			Blink	On
	Blink	On	R	G	B		
Silence		✓	●				
Intercom					●	✓	
Record Message			●	●		✓	
Failure Delete	✓		●	●		✓	
Failure Accept	✓		●	●			
Standby	✓	✓		●	●	✓	

Table 25. LED colors of the button assigned to the function Select Zone

FUNCTION	R	G	B	Blink	On
Block Zone	●	●			✓
Zone failure <ul style="list-style-type: none"> › short-circuit / ground fault / opening › impedance failure › switch to B side of the loop 	●	●		✓	
.....					
Zone failure confirmed	●	●		✓	
Emergency message playback	●				✓
Warning message playback	●			✓	
Voice message from a fireman microphone		●		✓	
Voice message (from a zone microphone, BGM)		●			✓
Service message playback			●		✓
Zone mute		●	●		✓
Buffering messages when zone is busy			●	✓	
Standby		●	●	✓	

Table 26. Color of the LEDs on the front panel of the control unit

Graphic symbol	Color		Control Unit SMART-CU-8LCD / SMART-CU-11LT/LCD
		green	POWER
		yellow	FAILURE
		red	ALARM

9.1 Normal mode

Activeness indicators and power supply indicators emit green light. In normal mode (no failure and locks) no LED in VASCU system emits yellow or red light.

9.2 Alarm mode

In this mode, all devices which are unnecessary during alarm (e.g. zone microphones, other devices which use structural network) are automatically disconnected.

An LED marked as ALARM emits red light on the fireman microphone, zone microphone and on the front panel of the Control Unit. Fire scenario is carried out. Any activities are recorded in the event log.

9.3 Failure mode

In case of damage related to one of the system modules, the system enters failure mode, and information about failure is displayed in the Control Unit and microphones. FAILURE yellow LED lights up. If the microphone has a button programmed as "confirm failure" the built in speaker also signals the failure. When failure is signaled, press the button marked as "confirm failure" to mute the alarm, the system will detect that the failure has just been accepted/confirmed by the Operator (this event is recorded in the event log). The failure LED goes out when the system damage is eliminated and "Failure delete" button is pressed.

9.4 Lock mode

VASCU can lock and unlock sound system zones. In the locked zone, no messages are played back until unlocked.

When the zone is locked, the LED indicator emits yellow color on every microphone.

10. Instruction for performing tests and trials

In order to confirm that smartVES VASCU works properly, perform a series of basic efficiency tests in accordance with the program below. Indicators and manual control elements used to perform the tests have been described in previous chapters.

10.1 Instructions for performing basic functions

10.1.1 Alarm mode

Activating alarm mode

Lift red button flap (alarm button “activate Evacuation”) and press it. Green LED indicators will emit light in all sound system zones. The system enters alarm state and automatically activates all zones. In this mode, music background and zone microphones are disconnected. It is still possible to send automatic alarm messages or via fireman microphone. The system awaits messages to given zones. The alarm state applies until the button programmed as “cancel alarm” is pressed.

Cancelling alarm

During alarm state, press “Cancel Alarm” button. VASCU inactivate all alarm messages.

Sending evacuation messages

Activate alarm and select zones. A green LED next to the zone name means the zone is ready to transmit. Press “Evacuation” button. A constant red indicator next to green zone selection indicator means that evacuation message is being sent. The evacuation message will be played back in given zones in a continuous way, until the button “cancel alarm” is pressed.

Sending warning messages

Activate alarm and select zones. A green LED next to the zone name means the zone is ready to transmit. Press “Warning” button. A flashing red indicator next to green zone selection indicator means that the warning message is being sent. The warning message will be played back in given zones in a continuous way, until the button “cancel alarm” is pressed.

Sending verbal messages via microphone

Activate alarm and select zones in which you wish to speak in. A green LED next to the zone name means the zone is ready to transmit. Lift the microphone, press and hold PTT – Push to talk button and speak at the same time. Speak slowly, loud and clearly.

Message priorities

Activate alarm and select zones. Press “Warning” button – warning message will be played back in given zones. Next, press the “Evacuation” button – warning message will stop, and evacuation message will replace it because has a higher priority. Then, press PTT button – all automatic messages will stop and you will be able to transmit a live message via the fireman microphone.

Transmitting automatic messages and microphone messages in various zones

Activate alarm and select one zone. Activate evacuation message or warning message playback in the given zone. Unselect this zone (green indicator goes out, red one still emits a constant light or flashes). Select another zone. To send a verbal message, press and hold “Push to talk” button and speak to the microphone.

Transmitting verbal messages when the central processing unit is faulty – CPU OFF

Set the switch on the front panel in the CPU OFF position. The CPU OFF LED will light up with a steady green light. Press “Push to talk” button and speak to the microphone.

- ▲ NOTE!** When the switch is in the CPU OFF position, playback of the alarm messages recorded in the smartVES memory does not work. The processor is bypassed. A direct connection between devices is created: microphone → amplifiers → loudspeakers. Microphone input is broadcasted to the entire system. Amplifiers operate at maximum amplification level – be aware that this rises the SPL significantly.

10.1.2 Failure mode

A flashing yellow FAILURE LED means that one of VAS central unit elements or a loudspeaker line is damaged. On SMART-CU-8LCD, SMART-CU-11LCD and ABT-DFMS the system failure will be indicated by the acoustic signal. When the damage is signaled, press “confirm failure” button to mute the alarm sound, and the system will register that the failure was confirmed by the Operator (this event will be recorded in the event log). The failure LED goes out when the system failure is eliminated and “cancel failure” button is pressed.

- ▲ A system maintenance technician or technical service must be notified of any damage immediately.**

10.1.3 Controlling backup power batteries

The internal battery resistance can be measured at any moment manually by using internal battery resistance function in the Power Supply Manager menu.

10.2 Testing the system

Instructions for performing tests which will confirm proper efficiency of the VAS central unit.

1. Get familiar with the VAS service manual.
2. Check if VAS system stops performing any functions unrelated to warning while switching into alarm mode.
3. Check if VAS system disconnects secondary sound systems (e.g. local audio systems of room tenants, connected to VAS as sources of background music, adverts, etc.) while switching into alarm mode.
4. Check if the system is capable of sending messages within max. 3 seconds after the fire alarm system central unit sends a fire alarm signal.
5. Check if the system is capable of sending voice messages to one or several areas at a time, in accordance with established alarm schedule.
6. Check if the VAS alarm message control algorithm by FACIE is carried out in accordance with the established fire scenario for the building.
7. Check if transmitting various messages to sound system zones is properly indicated on fireman microphone.
8. Play back alarm messages recorded on a memory card in the given sound system zone in order to confirm quality and comprehensibility of the message (verify all messages recorded in the memory).
9. Check if the verbal message is actually sent to the zone defined on fireman microphone, if sound system zones are actually audible in given sound system zones (do a test for all zones).
10. Check if VAS failure information is sent to FACIE and if this connection is supervised by FACIE.
11. Check if deactivation of a single amplifier causes switching into back-up amplifier.
12. Check if the system detects and signals failure of loudspeaker lines properly (short-circuit, open-circuit, loudspeaker line earthing).
13. Check if the damage in the system is detected within max. 100 seconds.

14. Check if "CPU OFF" switch works properly on the fireman microphone – it is a switch responsible for bypassing the central processor unit.
15. Carry out storage battery batteries test. Press "battery test" button and check if the indicator shows the right battery series resistance.
16. Check failure indicator on SMART-PSM48.
17. Switch off AC power and check if the system works properly on the backup battery power supply:
 - › check if the system performs all functions related to transmitting alarm messages played back from the memory,
 - › check if it is possible to send voice messages to particular zones via the fireman microphone,
 - › check if the system has disconnected secondary sources of sound connected to VAS cabinet, which do not participate in alarming,
 - › check if the sound level while sending messages remains unchanged as a result of switching into backup power,
 - › check if the system signals AC power failure.

11. Operation instructions

11.1 Control Unit

It is possible to navigate in SMART-CU-8LCD and SMART-CU-11LCD device menu via a touch-screen LCD display and nearby control buttons. The display shows a current VASCU system status. The menu allows the following:

- » monitor VASCU system status,
- » trigger loudspeaker line impedance measurement,
- » check network settings,
- » check software and firmware versions.

In case of damage in at least one of the system modules, the LCD display will show information about the fault.

The paragraph below describes operation instructions with an example of microphone panel configuration. The microphones are configured on a case-by-case basis for a specific purpose. During the first training, the person responsible for starting the system provides microphone operation manual.

11.2 Fireman microphone

Actions described below can be executed by authorize personnel only.

Sending verbal messages to given fire zones (fireman microphone)

- » Open red "Evacuation" button flap and press it. At this moment VASCU will switch into alarm mode.
- » Press a button applying to a desired zone. You can choose more than one zone. Green LEDs will light up next to selected zones.
- » Press "Push to Talk" button, hold the button and speak to the microphone. To finish transmitting, release the button.
- » Once the verbal message transmission has finished, the microphone status LED will go out.
- » To return to normal mode, press "cancel alarm" button.

Sending verbal messages to all zones

- » Open red "Evacuation" button flap and press it. VASCU will switch into alarm mode.
- » Press "all zones" button. Diodes located on the microphone and next to zones will emit green light.
- » Press "Push to Talk" button. While holding the button, speak to the microphone. To finish transmitting, release the button.
- » Once the verbal message transmission is finished, the microphone status LED will go out.
- » To return to normal mode, press "cancel alarm" button.

Activating warning message in selected fire zones

- » Open red “Evacuation” button flap and press it. At this moment VASCU will switch into alarm mode. Next, choose zones you wish to send the message to.
- » Green LEDs corresponding with selected zones will light up on the microphone.
- » Press “Warning” button. To deactivate the message, press “Clear” button.
- » To return to normal mode, press “cancel alarm” button.

Activating warning message in all zones

- » Open red “Evacuation” button flap and press it. At this moment VASCU will switch into alarm mode. Next, press the “all zones” button.
- » Green LEDs corresponding with all of the zones will light up together with the LED next to the “all zones” button on the microphone.
- » Press “warning” button. To deactivate the message, press “clear” button.
- » To return to normal mode, press “cancel alarm” button.

Activating evacuation message in selected fire zones

- » Open red “Evacuation” button flap and press it. At this moment VASCU will switch into alarm mode.
- » Press selected zones buttons. You can choose more than one zone. Green LEDs corresponding with selected zones will light up.
- » Press “Evacuation” button. To deactivate the message, press “clear” button.
- » To return to normal mode, press “cancel alarm” button.

Activating evacuation message in all zones

- » Open red “Evacuation” button flap and press it. At this moment VASCU will switch into alarm mode. Next, press the “all zones” button.
- » Green LEDs corresponding with all of the zones will light up together with the LED next to the “all zones” button on the microphone.
- » Press “Evacuation” button. To deactivate the message, press “clear” button.
- » To return to normal mode, press “cancel alarm” button.

Mute

- » In alarm mode it is possible to mute warning and/or evacuation messages. To do so, choose zone and press “mute” button. The messages will not be audible in this location.
- » You can choose all zones and press “mute”. Then, messages for the entire system will be muted.
- » Remember that alarm mode is active all the time – (the LED next to the ALARM symbol on the microphone chassis is on), contacts, controls and settings assigned to the alarm scenario are maintained. Muting operation is recorded in the event log.
- » Choose zone and activate warning or evacuation action to send messages again.
- » To return to normal mode, press “cancel alarm” button.

11.3 Zone microphone

Sending voice messages to a selected zones

- » Press chosen zone button. You can choose more than one zone. Green LEDs corresponding with the selected zones will light up.
- » Press “push to talk” button. Speak to the microphone while holding the button.
Note: Depending on the settings of the “push to talk” button, the button may work in the following way: first press activates the microphone, second press – deactivates.
- » The system can generate a gong (sound preceding the message). Once the gong has ended the “microphone active” LED will come back on.
Note: While sending messages from the fireman microphone, the gong is not emitted.
- » The verbal message can be sent via the microphone when the “microphone active” LED is on again. To finish transmitting messages, release the PTT button.
- » Once the verbal message has finished, LEDs corresponding with the selected zones will go out. The microphone active LED will also deactivate.

Sending verbal messages to all zones

- » Press “all zones” button.
- » Green LEDs corresponding with all of the zones will light up together with the LED next to the “all zones” button on the microphone.
- » Press “Push to Talk” button, hold it and speak to the microphone.
Note: Depending on the settings of the “Push to Talk” button, the button may work in the following way: first press activates the microphone, second press – deactivates.
- » The system can generate a gong (sound preceding the message). Once the gong has ended the “microphone active” LED will come back on.
Note: While sending messages from the fireman microphone, the gong is not emitted.
- » The verbal message can be sent via the microphone when the “microphone active” LED is on again. To finish transmitting messages, release the button.
- » Once the verbal message has finished, LEDs corresponding with the selected zones will go out. The microphone active LED will also deactivate.

Select sound source – dynamic assignment

- » Choose zones you wish to assign source of sound to. You can choose more than one zone.
- » Choose button defined as source of sound you wish to use.

11.4 Power supply manager

Buttons of the front panel are used to control the device via menu.

Menu allows the following:

- » Monitoring power supply unit, charger and batteries condition,
- » Measuring connection, fuse and storage battery series resistance,
- » Checking battery temperature and reviewing the list of failures.

It is also possible to activate service mode in which you can choose a number of power supply units, activate storage battery protection system, set battery capacity and check power supply manager software version.

Please see section: 7.1.8.5 – SMART-PSM48 Front panel operation – Enter Service Mode

12. Maintenance and service

12.1 Preparations before VAS system maintenance works

12.1.1 Initial procedures for system testing

Schedule the time of VAS system maintenance works with the building administration, inform the site administrator about activities and range of performed works, as well as about potential inconveniences during VAS inspection.

12.1.2 System testing

Inform the building administrator that VAS system is about to be tested.

Inform the building administrator and staff (e.g. guards) that it is likely that they will experience alarm and warning messages, together with inconveniences arising from system testing procedures.

Inform FACIE monitoring center possible triggering of the remote alarm or damage signal.

Considering hazardous voltage inside the operating devices, maintenance works can be performed only if the source of power has been switched off.

All repairs must be carried out by qualified technicians or engineers. To send a service request, contact your nearest Ambient System representative.

The manufacturer shall not be held responsible for any damage caused by unauthorized modification or repair.

VAS central unit safety check and electrical inspection:

- » Check if the external side of the cabinet complies with IP30 norm.
- » Check conformity notification with EN 54-16 in the front of the cabinet.
- » Check conformity with EN 54-4 on the charging device.
- » Check conformity with EN 54-24 for loudspeakers.
- » Check if front and rear doors are closed.
- » Check if indicators visibility of VASCU is GOOD.
- » Check and measure VASU cabinet earthing connection.
- » Check log history – VASU event log.
- » Check fire signaling central unit interface together with customer's engineer.
- » Check all of the sound correction parameters. Save and compare settings of control elements with previously recorded data. Note and investigate all deviations.
- » While evacuation message playback (use external load if the use of main speaker lines is not possible), check output level of the smartVES device. Save and compare with previous data.
- » Check automatic system defect monitoring and test by causing a fault.

Loudspeakers:

- » Measure total speaker load for each circuit, save and compare with previous results. Inspect all unexpected changes.
- » Perform subjective sound quality assesment and audibility tests in all areas with restricted access. Save sound pressure levels (SPL).

Microphone control devices:

- » Control condition and proper operation of switches/touch-fields.
- » Check microphone overall physical condition.
- » Transmit a test message, use a monitoring speaker whenever the use of main speaker lines is not possible.

System condition:

- » In case of inside the central unit chassis, it is recommended to clean it with a vacuum cleaner or use compressed air. The Central Unit must remain dry at all times, do not use water to clean it.

On-site changes:

- » Survey all areas which were subject to changes (specified by the Customer) and determine if the loudspeaker range is suitable.

Maintenance log:

- » After you finish all operations, enter maintenance results to the maintenance log.

Checklist:

- » Upon finishing maintenance, get a relevant person to sign your checklist, confirming that the system has been left in a fully operational condition. Documentation should also include your recommendations and remarks.

12.2 System maintenance

12.2.1 Daily review

All abnormalities are usually identified by the staff operating the system. VAS system operators should notify a “responsible person” of any identified problems related to the system. Any remarks should be entered into the maintenance log on a regular basis.

12.2.2 Inspection every 6 months

- ✓ Ask VAS system users about any remarks concerning system operation.
- ✓ Check maintenance log records related to inspections, repairs and controls.
- ✓ Review and read VAS system documentation.
- ✓ Review RACK system cabinet elements condition (pay attention to temperature, corrosion, humidity, cleanliness, etc.).
- ✓ Check connections, clamps and cables between particular VAS devices.
- ✓ Check for any device damage in RACK cabinet.
- ✓ Check if all lights, LEDs and indicators work properly.
- ✓ Check network and battery fuses condition.
- ✓ Check connectors and earthing connections condition.
- ✓ Check batteries in terms of corrosion and ventilation.
- ✓ Check if the battery charger works properly.
- ✓ Switch off AC power and check battery power system operation:
 - › check if the system performs all functions related to transmitting alarm messages recorded in memory,
 - › check if fireman microphone can transmit voice messages to particular zones,
 - › check if the system deactivated other PA sources connected to VAS cabinet – which do not participate directly in alarming,
 - › check if the system signals AC power failure.
- ✓ Check if information about VAS failure is sent to FACIE central unit and if this connection is monitored by FACIE central unit.
- ✓ Check if VAS alarm message control algorithm by FACIE central unit is carried out in accordance with the established fire scenario for the building.
- ✓ Check if the verbal message transmitted to the sound system zone declared on fireman microphone is actually audible in the given sound system zone (do tests for all sound system zones).
- ✓ Check if “CPU OFF” switch works properly on the fireman microphone – activating the central processing unit bypass.
- ✓ Play back alarm messages recorded on the memory card in the given sounds system zone in order to confirm the quality and comprehensibility of the message (check all messages recorded in the memory).
- ✓ Check if connections between SAP and VAS are monitored.
- ✓ Check if VAS system stops performing any functions unrelated to warning when the alarm is triggered.
- ✓ Check if VAS system disconnects all secondary systems when the alarm is triggered.

-
- ✓ Check if the system is capable of sending warning signals and verbal messages to one or several zones at a time, in accordance with the established fire procedure.
 - ✓ Check if the system identifies and signals speaker line failure properly (short-circuit, open-circuit, earthing of loudspeaker line).
 - ✓ Check if it takes the system no longer than 100 seconds to detect and signal the fault.
 - ✓ Once per 6 months it is necessary to check and confirm proper performance of loudspeakers in 50% of the area of the building (100% of the area must be inspected within a year). The test must be performed by forcing loudspeaker lines to emit any signal (e.g. CD music, via microphone or previously recorded message or test sound) and by checking if all loudspeakers on the given line emit the test signal properly. While carrying out the aforesaid test, you need to check for any changes in the interior requiring relocation of loudspeakers or change of their number. Also inspect if the speaker system has been maintained properly, check for dirt, paint and mechanical damage.
 - ✓ Check if transmitting messages to various zones is properly indicated on the fireman microphone.
 - ✓ Check cooling fan condition.
 - ✓ Disconnect the backup power batteries. Measure voltage on the charger output and on the battery terminals.
 - ✓ Use software to check event log and system time clock settings.
 - ✓ Use diagnostic software to check the following:
 - › microphones,
 - › power supply system,
 - › power supply manager,
 - › amplifiers,
 - › extension cards.

12.2.3 Annual inspection

All maintenance works included in the 6-month inspection apply here, yet additionally:

- ✓ Perform sound pressure level tests in randomly selected areas of the building in order to verify if there are no changes causing a decrease of parameters below the required values by EN 60849 norm.
- ✓ Check if impedance of particular loudspeaker lines is in compliant with the blueprint.
- ✓ Check alarm message scenarios sent by FAS
- ✓ Measure battery capacity – if the capacity dropped below 80% of the design capacity, batteries must be replaced.
- ✓ Safety inspection must be carried out frequently, at least every 12 months; the manufacturer recommends to take maintenance actions every 6 months.

12.2.4 Manufactures remarks

Please note that Ambient System is not responsible for results of unauthorized repairs.

Any repairs of the equipment should be carried out by the Ambient System or a service centre authorized by Ambient System.

In any unresolved issues, please contact Ambient System's trained personnel. Content contained herein is subject to change without notice. Ambient System reserves the right to change or modify the product and conditions applicable to the use of this product at any time.

13. smartVES Configuration Software

13.1 Welcome screen

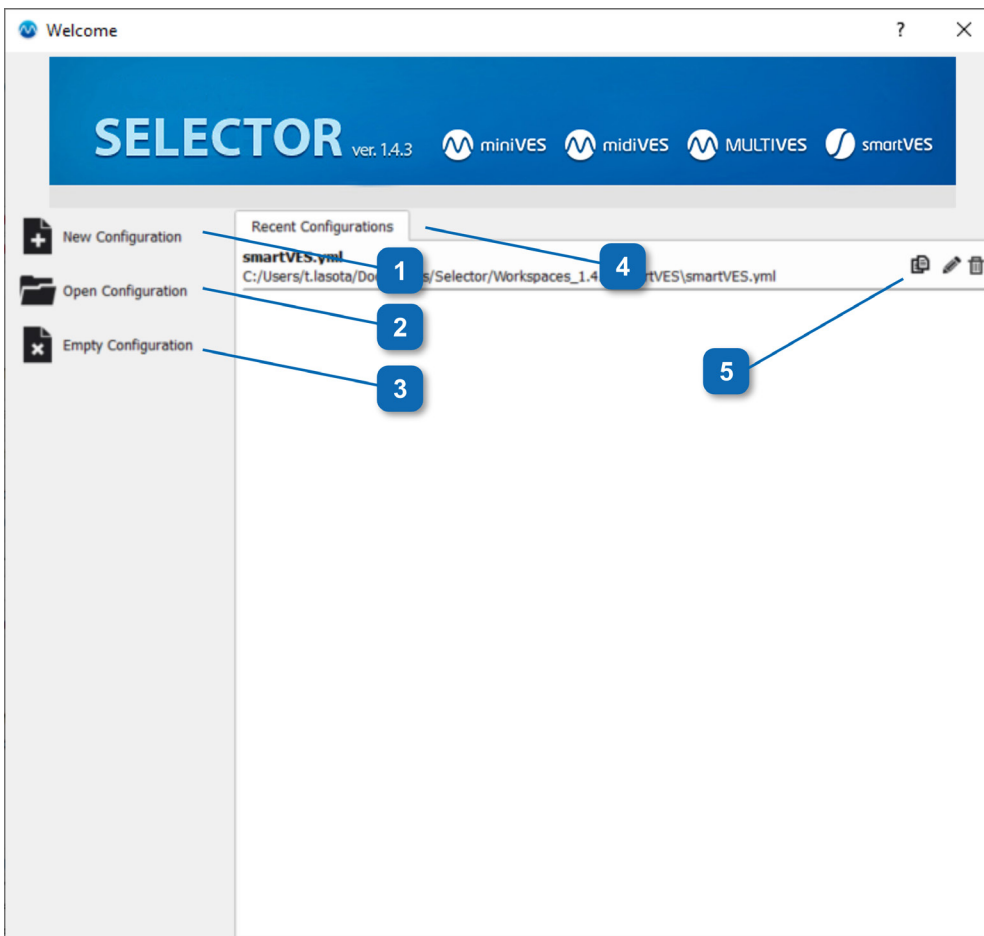

1 New configuration file localization

In order to start a project a dedicated folder for the configuration file needs to be created.

Caution: Do not select an existing folder with data, as these will be deleted!

2 Selection of configuration file from a chosen location

3 Creating a new project without saving

4 Recent and template configuration file window

5 Project cloning, changing and deleting project name

13.2 Basic Configuration

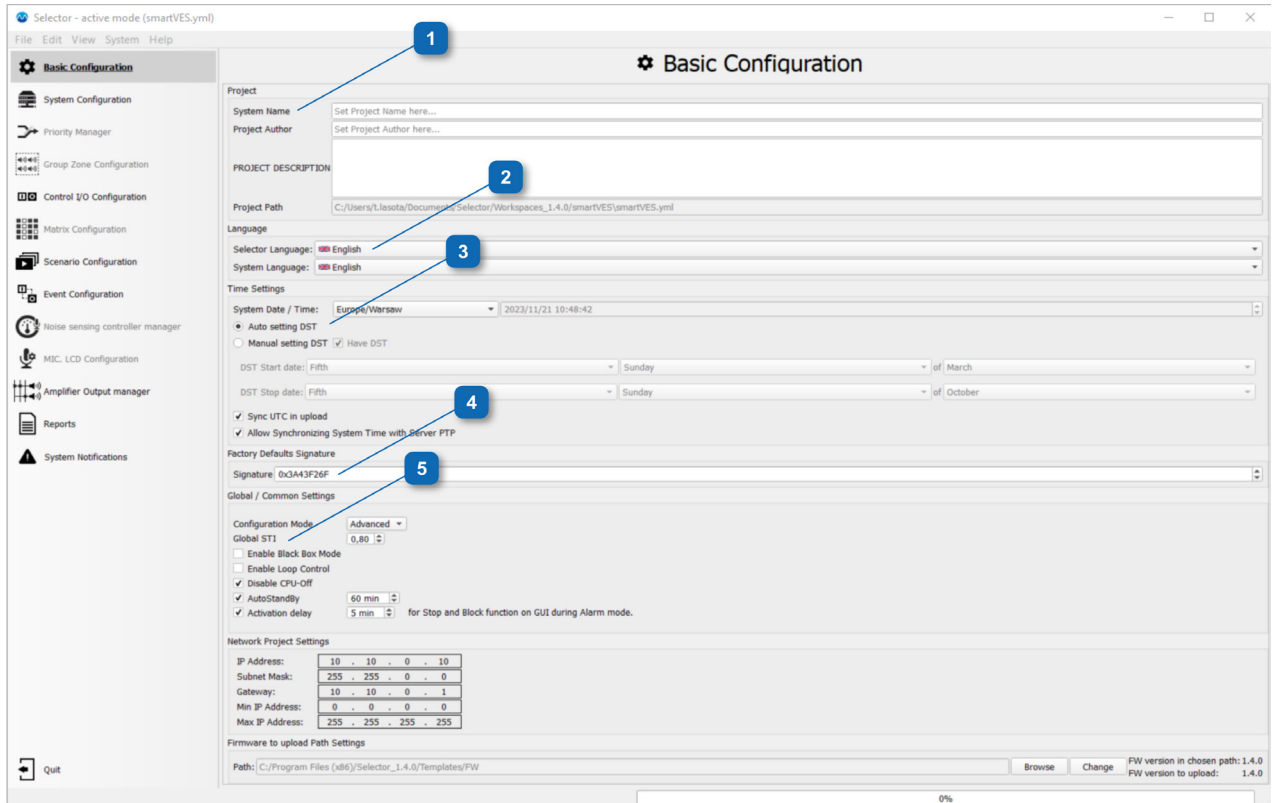

1 Project name and author window, with designer's note

The **Project** field contains basic information on configuration of the smartVES system. The name of the project and its author should be supplemented here, as well as a description which should include as many detailed data as possible, such as the place and date launched, specific features of the system, customized functions. The more detailed the project description the easier servicing and making changes in the system at a later date.

2 Language selection

The **Language** field defines the current language of the software used to configure the smartVES system – **Selector Language**. **System Language** defines current the language of all available GUI touch screens in the system.

3 System real-time clock setting

Setting the system valid time. The configurator downloads the UTC from the operating system on which the configurator is installed. In order to load time together with configuration, accept the **Sync UTC** in upload window and select the appropriate time zone in which the system will be installed. It's possible to turn daylight savings time on and off in this section. Choose **Auto setting DST** for the time to be advanced by 1 hour on the last Sunday of March at 1:00 universal time and retarded accordingly on the last Sunday of October. This applies to countries within the EU among others (UE 2000/84/EC directive). In this mode if the computer running the software is in a daylight savings zone the Selector software will act accordingly and display **DST start** and **stop dates**. It's possible to manually override the transition dates by using the next option **Manual setting DST** along with **use DST** (without the latter daylight savings time will be disabled). Additionally time can be updated automatically by a PTP server connected either to the LAN port of the central unit or the LAN/WAN port.

4 Signature

Every project is assigned with a unique signature number. If the signatures between the project uploaded to the system and the one on the project in the computer software differ, the system will not allow returning to factory settings.

5 Configurator work mode

In the [Global Settings](#) you can choose one of the configurator work modes. In the [Advanced](#) mode you have access to creating speaker zone groups, creating logic input groups, timers and scenarios, all of which are unavailable in [Simple](#) mode. Additionally you can set individual zone microphone LED behaviour in the output configuration section. [Enable Black Box](#) – this function activates audio recording on the fireman microphone when the system enters alarm mode. [Enable Loop Control](#) – activating this function enables error reporting in the fiber optic network connection.

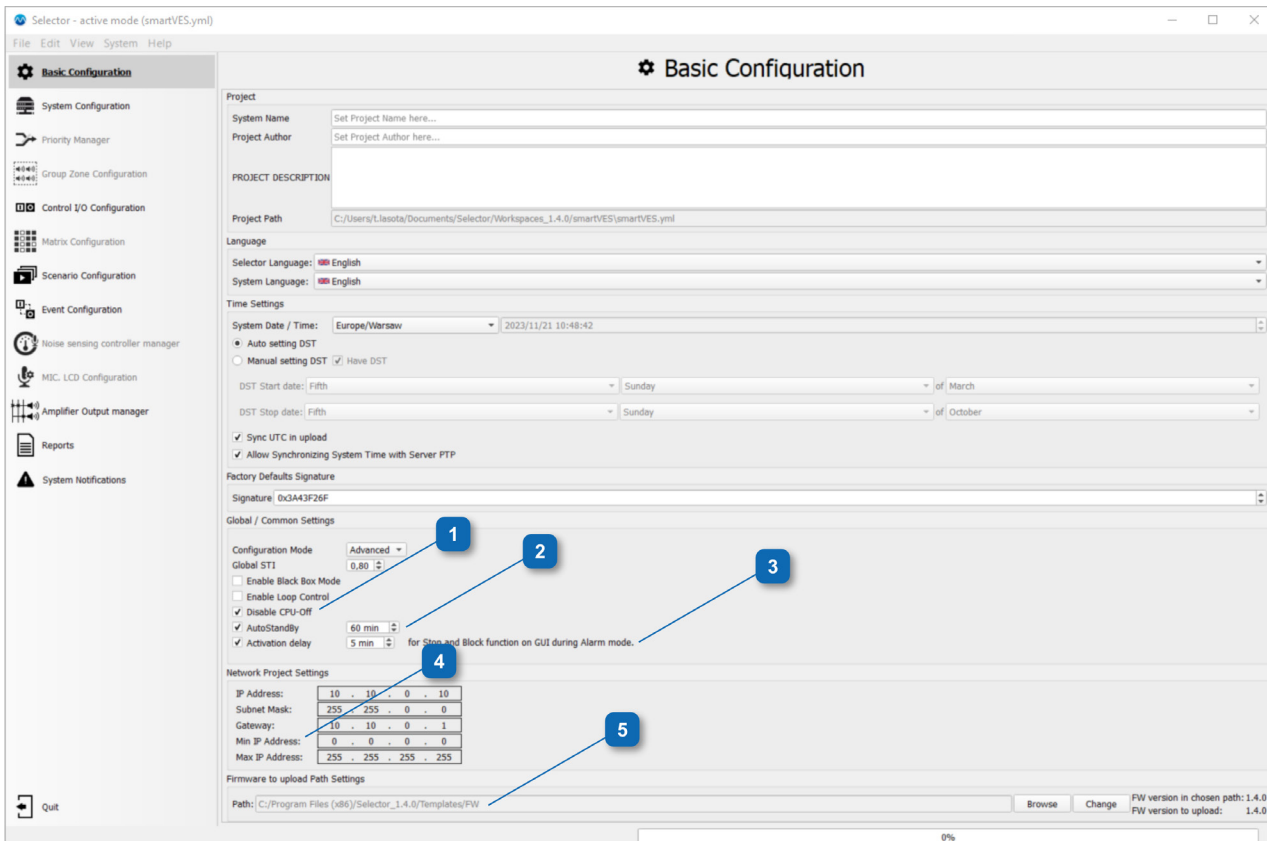

1 Disable CPU-OFF

This option in its default setting (on) disables the central processing unit bypass mode. In order to activate the CPU-Off function accessible from the ABT-DFMS and smartVES front panel by a dedicated switch, uncheck this box.

2 AutoStandBy

Enabling this mode in the smartVES system results in:

- › limiting current draw from the batteries when in emergency power mode
- › limiting heat generated by the amplifier modules during standard operation mode

The system enters [Standby](#) mode when no audio has been transmitted through the system for the time set in the software. The time is set in minutes in the 15 to 300 bracket. The default state of this option is active with the default time set to 60 minutes. For more details see the appendix section.

3 Defining IP address pool to assign system devices

This window shows the range the configurator uses to assign IP addresses to all programmable elements of the smartVES system in the internal system network. It is possible to change the settings of the assigned pool, however it is not recommended by the manufacturer. The settings should be changed prior to adding the first device to the workspace.

4 System firmware update field

Every software version has a corresponding firmware that is uploaded to the Central Units, fireman microphones and zone microphones. Every time a new configuration is uploaded to the system, the configurator software compares firmware versions. If a different firmware version than the one in the configurator is detected, it will be overwritten. It's possible to load

a different (newer) firmware version than the one supplied with the software. In order to do so you must manually set the new firmware path by clicking [browse](#). The new firmware path will appear in the [path](#) window. In order to upload the new firmware to the system, click [change](#) – this will display the new firmware version in the [FW version to upload](#) field. For more details see the [Appendix](#) section.

13.3 System Configuration

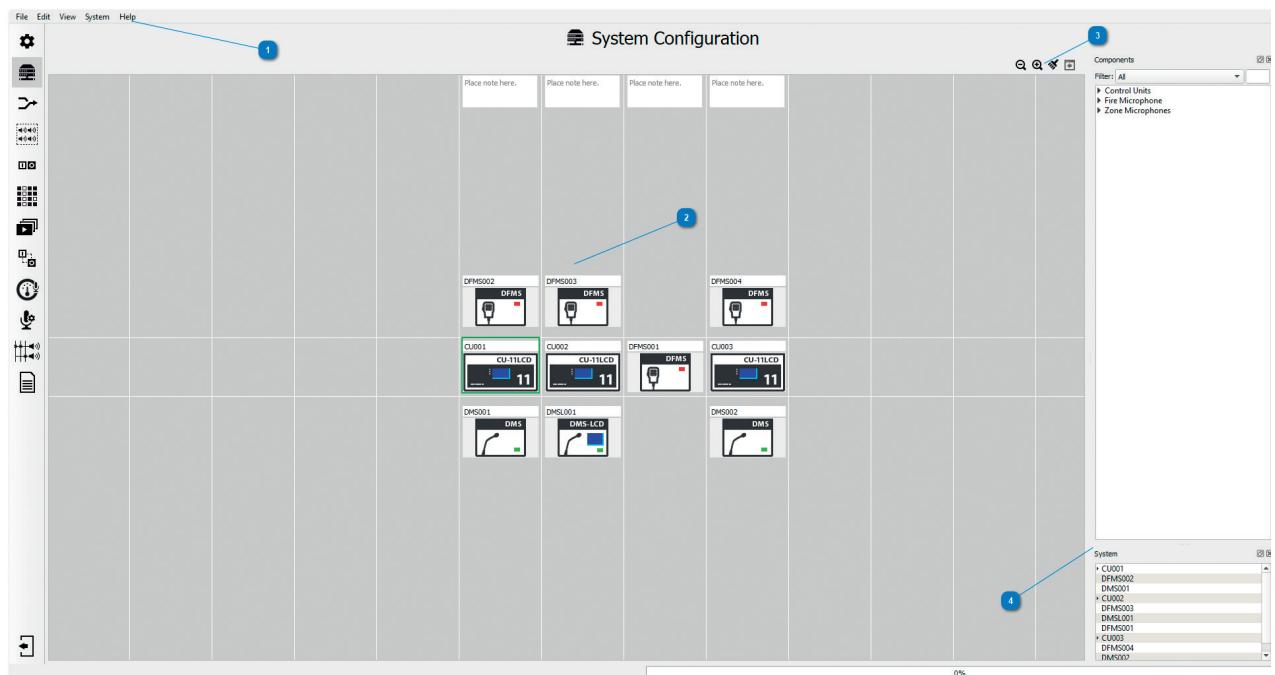

1 Main Menu bar

[File](#), [Edit](#), [View](#), [System](#), [Help](#)

2 Workspace

The [System Configuration](#) tab is one of the most important items in the smartVES system configuration software. The main window, called [Workspace](#), represents system connections by means of vertical and horizontal lines. Placing devices along a vertical line represents a copper wire connection within a single location. The horizontal space between the two lines in the center of the workspace represents a fiber optic connection. Devices placed next to each other within this space are connected by a fiber optic link and are often separated by a greater distance. Additionally, all of the connections upwards from the central fiber connection part of the workspace are monitored – the system checks for device and link fault. The system elements placed below the central field (zone microphones) will not be monitored.

3 Components

In the top right part of the work field there is the tab with all available elements of the smartVES system – the [Components](#) tab. In order to find it press the arrow next to [Control Units](#) in the components tab and a list of available units will drop down, next simply use the drag&drop method. The software suggests, with a grey rectangle, where a given element can be placed only if the cursor with the element being drawn is located within the work field. Repeat the procedure for [Fireman Microphones](#) and [Zone Microphones](#) tabs.

4 System

In the bottom right part of the work field there is the tab [System](#). This tab is used for detailed configuration of the devices and shows allocation of cards in individual control unit slots. Having added a control unit to the work field, the name of the unit will appear in the system tab as well as a triangle icon meaning a drop-down list. Right-clicking on the name displays

the option [Go to configuration](#). When the list drops down, a list of available slots will be displayed. Right-clicking on a slot displays additional option of [Go to configuration](#) (card detailed editing), [Add Control/Function Card](#) – adding a card to an empty slot or changing allocation of the card in the slot, [Remove Card](#) – removal of a card which was assigned to a slot before. In addition, detailed editing of elements from the work field may be triggered by double-clicking of the left mouse button on each of the devices in the work field. If the device contains more elements to be configured, as in the case of control units, then the first double click of the left mouse button results in moving to the next level of editing where we can see all defined cards in a unit. A next double click on any available element means moving to the detailed parameter card of a given element. *A detailed description of the editing window for individual elements of the smartVES system is available in the following tabs: [DFMS](#), [DMS](#), [xCtrlLine-2/4](#), [xLogIN-8c/f](#), [xLogOUT-8c/f](#), [Audio-4/12](#).*

13.3.1 File

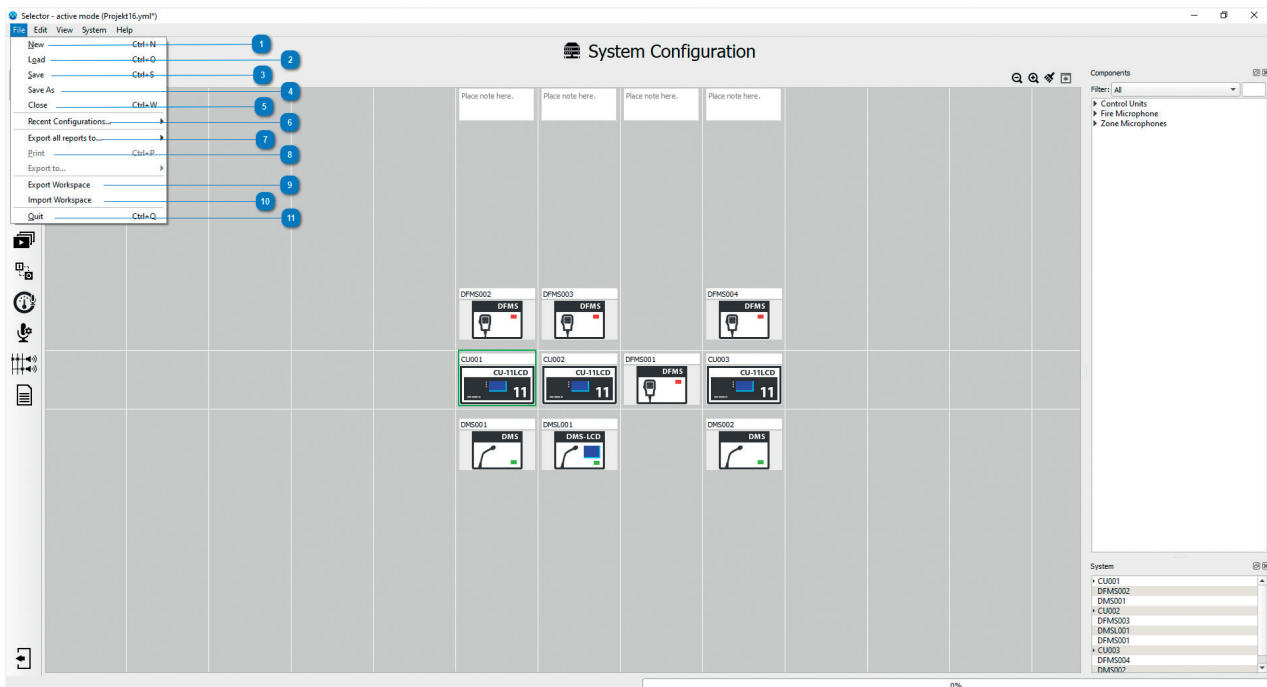

- 1 New**

This option creates a new folder in which all configuration data for a given project will be saved. In order to create a folder, click the "folder with a plus sign" icon. Creating a new or selecting an existing folder is the first thing to do to be able to go on with the configuration of the system. **Caution:** Selecting a folder with an earlier created configuration results in having the data in this folder completely deleted for the purposes of a new project.
- 2 Load**

This loads a system configuration created earlier. The configuration file has the extension *.af.
- 3 Save**

This saves a configuration in the created Workspace folder.
- 4 Save as**

This saves a configuration in the created Workspace folder enabling a change of the *.af configuration file name.
- 5 Close**

This closes the current configuration file.

6 Recent Configurations

The configuration software stores up to 10 recently used system configurations, you can load them using this list.

7 Export all reports

This generates tables from the [Reports](#) tab in one of the following formats: HTML, PDF, XML, ODF.

8 Print

Prints all available reports generated by the configurator.

9 Export Workspace

All configuration files, together with messages, are compressed into a file with the extension *.afz. This is a complete record of the configuration, unlike files with the extension *.af which do not contain messages.

10 Import Workspace

Automatic decompression of a *.afz file and loading the complete configuration of the system.
 See [FAQ 3: cannot open downloaded system configuration](#).

11 Quit

Closing the smartVES system configuration software.

13.3.2 Preferences

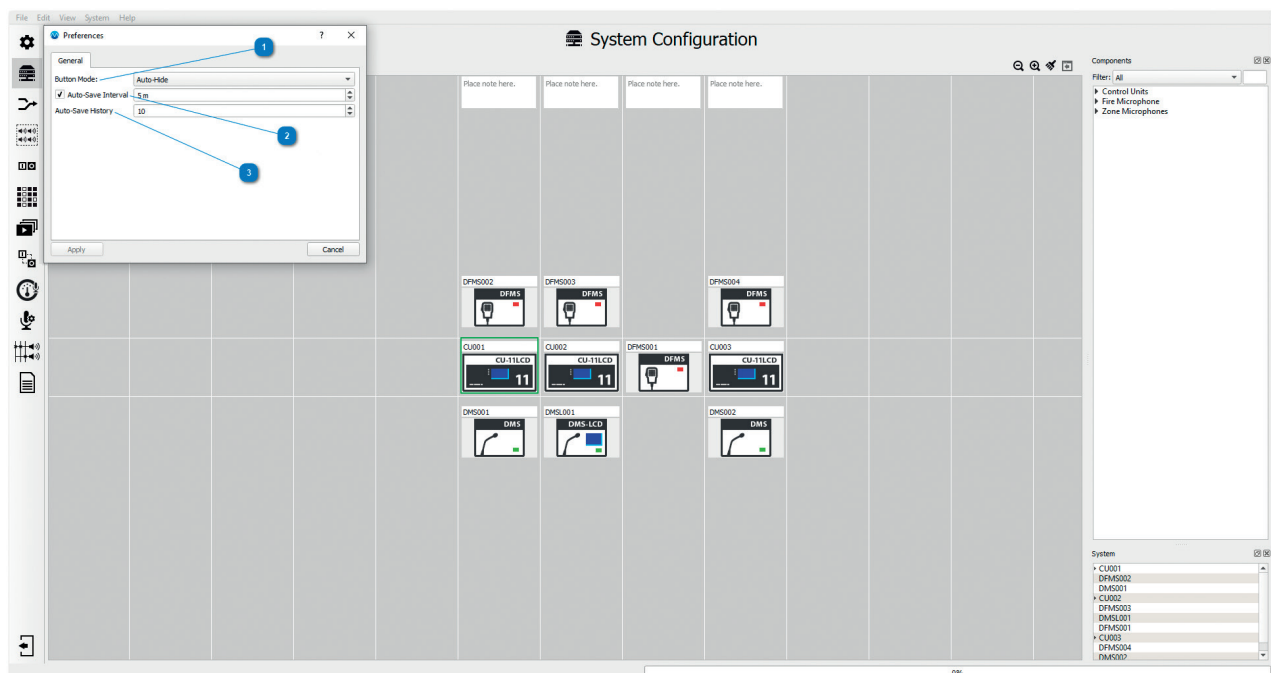

1 Button Mode:

This enables personalization of the view of the configuration software. In the [Auto-Hide](#) mode, the main icons, such as [Basic configuration](#), [System configuration](#), [Priority Manager](#), [Group Zone Configuration](#), [Matrix](#), [Scenario](#) and [Event Configuration](#) have no subtitles and moving the mouse cursor over an icon results in all icon names being displayed:

Text and Icon – icons and names are always visible

Icon only – only icons are always visible

Text only – only names are visible

2 Auto-Save Interval

This option, when activated, results in having the current configuration saved into the configuration file at predefined intervals expressed in minutes.

3 Auto-Save History

In this section you declare the number of autosave configurations you wish to be stored in the software. It is closely linked to the autosave interval, if the interval is set to 1 minute and the value of the autosave readout is 10, then the configurator will allow to load the maximum of 10 minutes back. Of course, both the save interval and the number of files to read may assume a value from 1 to 99.

13.3.3 System

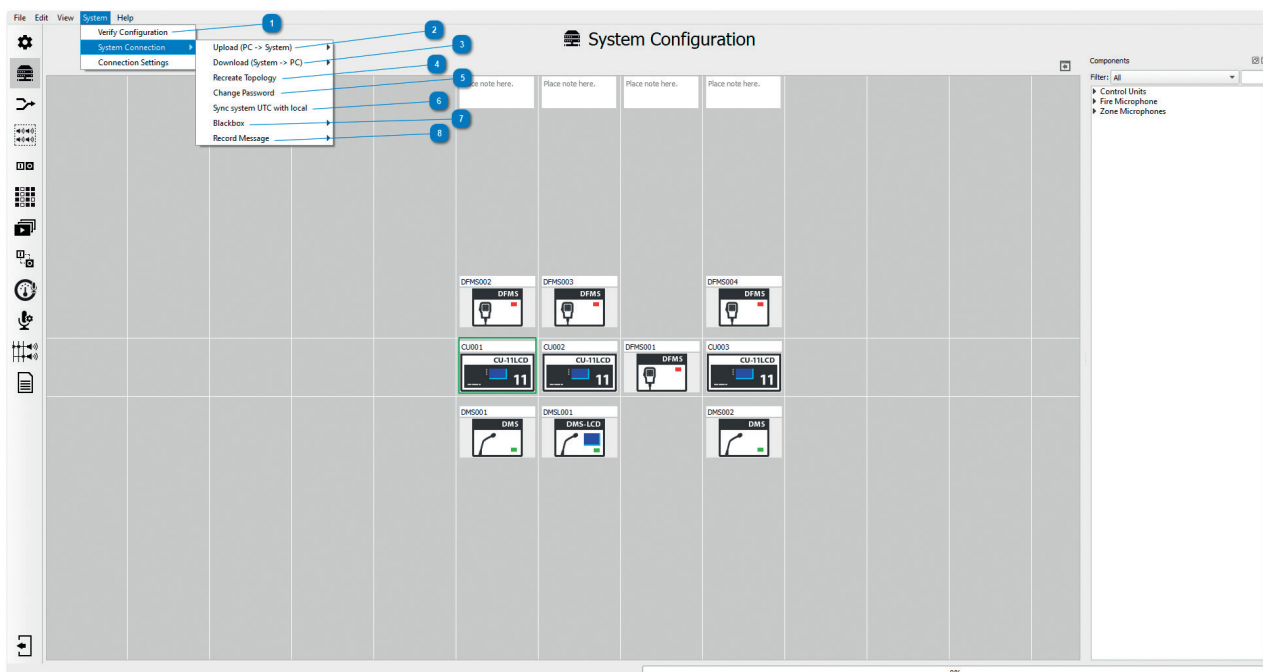

1 Verify Configuration

The configurator checks created configuration for its integrity. It classifies verified elements into 3 groups – **Errors**, **Warnings** and **Info**. If the software detects configuration errors, it will not allow it to be loaded into the system. By selecting [Show details](#), we gain access into the details of the problems which have occurred.

2 System Connection / Upload (PC -> System)

This allows to send a configuration, created on a PC running the configurator software to the smartVES system connected to that PC. Prior to sending the configuration to the system, the software verifies the configuration file. [Upload full configuration](#) – sends the entire configuration from the PC to the system, including audio files in the PCM format. Loading of a full configuration must be executed for the first time an empty system is being programmed, every successive configuration change which does not require changes in audio files may be loaded into the system via [Upload configuration without audio](#) which makes programming of the system much faster.

3 System Connection / Download (System -> PC)

This allows to download the current full system configuration or the configuration prior to the current one from system into a PC.

4 System Connection / Recreate Topology

This function reads the system architecture. The system is able to identify cards located on a particular slot of the control unit, it detects all zone and fireman microphones connected and the method and place of connection of the units and microphones (optical fibre, cat5). **Caution:** the only element which is not detected by the system recreating topology are microphone extensions.

5 [System Connection / Change password](#)

Allows to change the previously set password needed to upload the configuration to the system. The change is authorized either by entering the previous password or by generating a token. The token is created by Ambient System after received a five digit code generated by the Control Unit GUI (applies only to units equipped with LCD screens).

6 [System connection / Sync system UTC with local](#)

This option synchronizes the system's internal clock with the time on the computer running the configurator software.

7 [System Connection / Blackbox](#)

The [Blackbox](#) function records audio from all connected DFMS fireman microphones while the alarm mode is active. [Download blackbox buffer](#) retrieves the data stored in the microphones. [Clear blackbox buffer](#) - erases all the messages recorded during alarm mode.

8 [System Connection / Record message](#)

If this function has been enabled in the system you can download the messages recorded by DFMS, DMS or DMS-LCD microphones by clicking [Download record message buffer](#). [Clear record message buffer](#) deletes all the messages.

13.3.4 System Connection Settings

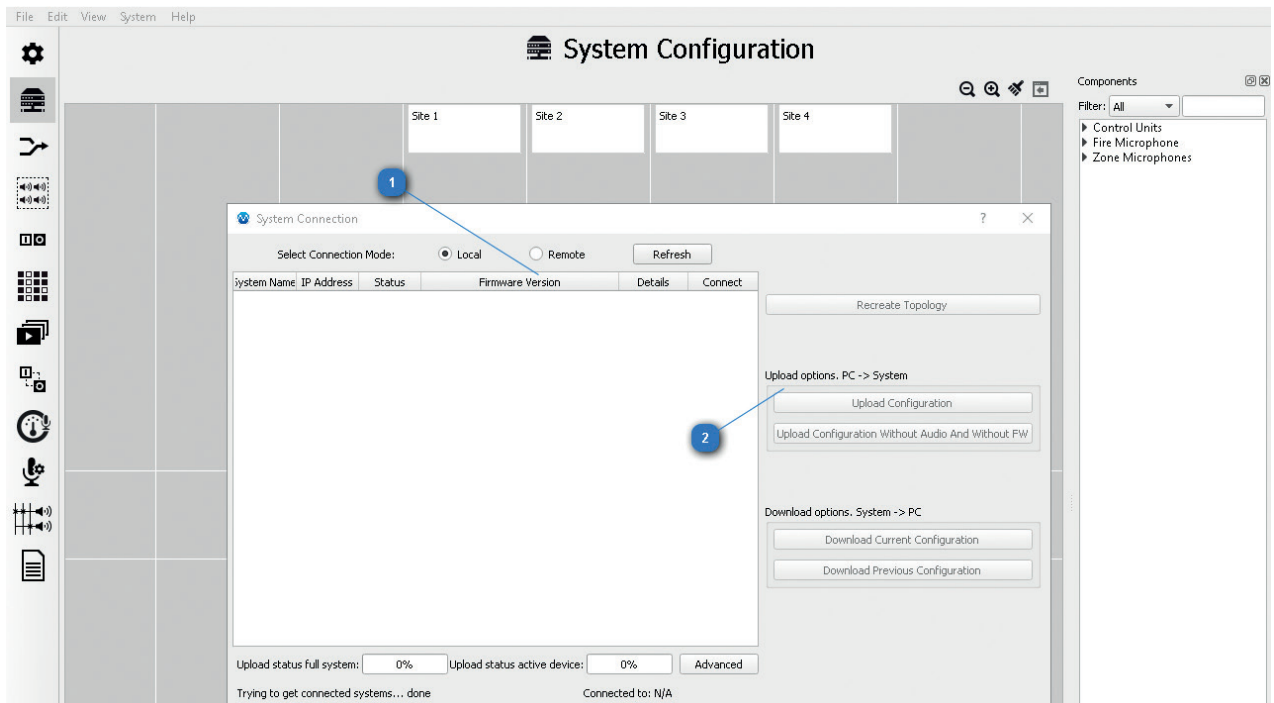

1 [Connection Settings](#)

This window allows the system to connect with a PC. Network card of the PC with smartVES Selector should be configured in such a way that the Internet Protocol Version 4 (TCP / IPv4) should be set to obtain an IP address automatically. The connection between the PC and the control unit or DFMS should be achieved through the LAN / WAN connection.

If the connection is properly configured server called the same as a project that is uploaded to the system should appear in the [Connection Settings](#). In the case of connecting to a clean unconfigured system, the server will be named [NewSystem](#). smartVES system is using the AutoIP protocol to assign an address from the special address pool 169.254.x.x to the communications card of the control unit and the network card of the PC. If a connected server does not appear in the window – see [FAQ 1 Server not visible in the connection window](#). In the case of an external active DHCP server in the network (e.g. a switch) the IP addresses are assigned to both the PC and the smartVES system. The [Remote](#) option – this allows the configurator to connect to the smartVES global server. All units worldwide with an internet connection and the owners consent to do so connect to the global server. Through the smartVES global server, the Ambient System support team may upgrade the software, create configurations and detect system errors.

This window also displays progress while loading a new configuration into the system. Having the configuration loaded, the [Connection](#) window will have a message displayed [Uploaded, the same configuration](#) which results in having two identical configurations existing on the PC and the smartVES system.

2 [Connection Settings options](#)

[Recreate Topology](#) – this function reads the system architecture. The system is able to identify cards located in a particular slot of the control unit, it detects all zone and fireman microphones connected and the method and place of connection of the units and microphones (optical fibre, cat5). **Caution:** the only element which is not detected by the system recreating topology are microphone extensions.

[Upload options. PC -> System](#) – this allows to send a configuration, created on a PC running the configurator software to the smartVES system connected to that PC. Prior to sending the configuration to the system, the software verifies the configuration file. [Upload full configuration](#) – sends the entire configuration from the PC to the system, including audio files in the PCM format. Loading of a full configuration must be executed the first time an empty system is being programmed, every successive configuration change which does not require changes in audio files may be loaded into the system via [Upload configuration without audio](#) which makes programming of the system much faster.

[Download options. System -> PC](#) – this allows to download the current full system configuration or the configuration prior to current one from the central unit. For this purpose, the file “config.afz” is downloaded to the folder “downloadedconfiguration” of the project. Launching the downloaded configuration is done through the [Import Workspace](#).

13.3.5 Workspace

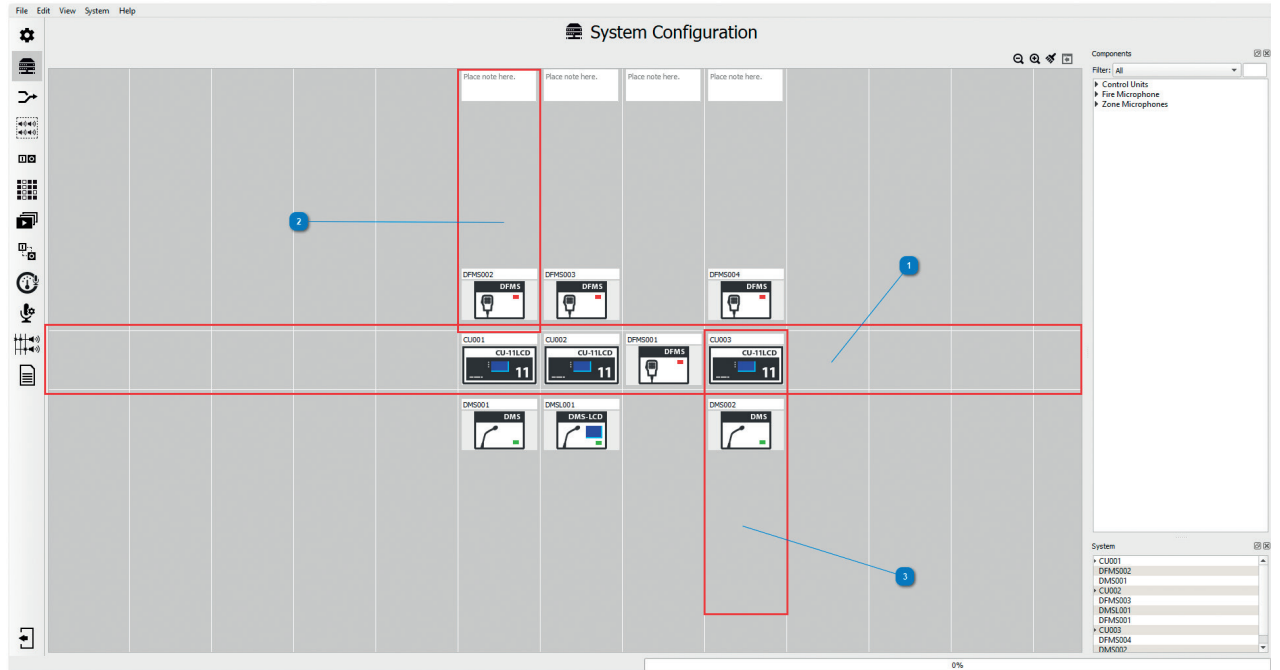

1 Fibre-optic link horizontal line

System elements arranged along this line are connected to each other by means of an optical fibre. The fibre-optic link makes the main communication loop of the system. The types of the connectors are specified in the technical documentation.

2 Vertical line of system component connection by means of Cat5 UTP cable – monitored

System elements are arranged along a vertical line. Within one column, they are connected to each other by means of a Cat5 UTP cable. This is a local connection, monitored within one location, intended only to connect control units and fireman microphones.

3 Vertical line of system component connection by means of Cat5 UTP cable – unmonitored

System elements are arranged along a vertical line. Within one column, they are connected to each other by means of a Cat5 UTP cable. This is a local connection, unmonitored, intended only for zone microphones.

13.3.6 System Configuration

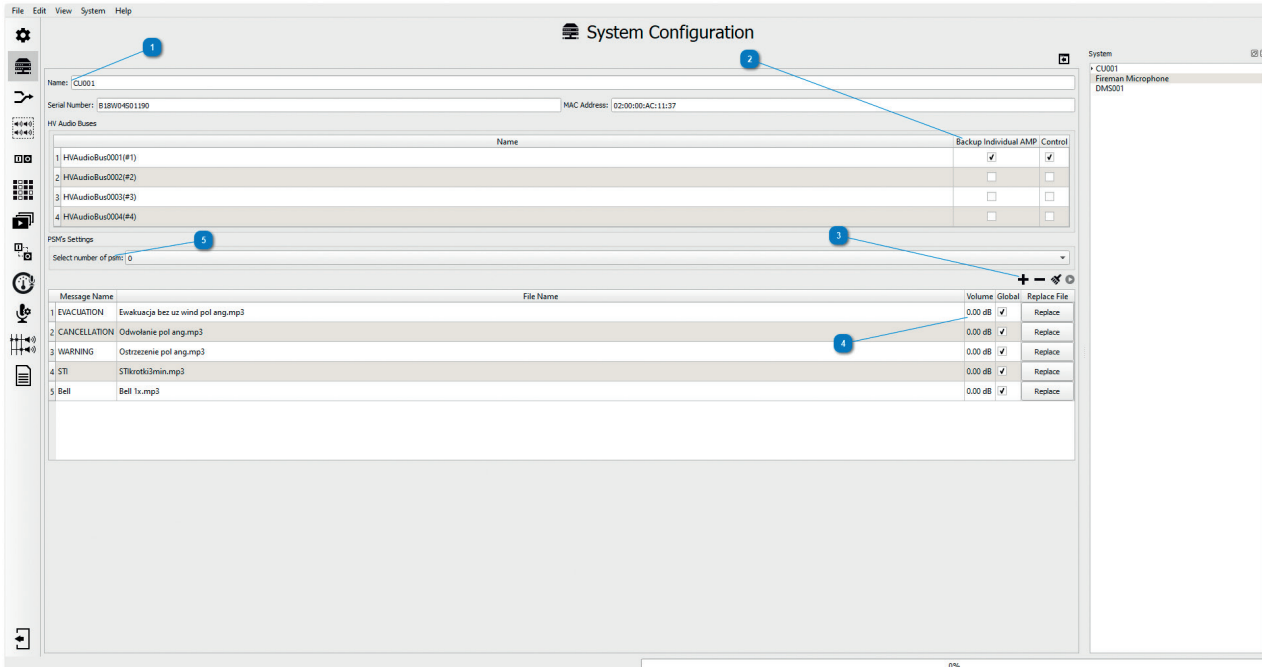

1 Change of unit name

2 Editing HVAudioBus 1-4

We can mark if the system is to supervise the presence of an amplifier on a given bus – [Control](#). [Backup](#) is used to declare a backup amplifier in case of a failure of one of the amplifiers supplying the control card via an individual input – [HVAudioInput](#). In case a failure occurs of an amplifier supplying only one control card, the system will switch this card over to be supplied by an amplifier attached to a selected [HVAudioBus](#) with the options [Backup](#) and [Control](#) selected. *See the description for assignment of backup amplifiers.*

3 Adding messages to system

Selecting the icon **+** we add a sound file. The configuration software accepts formats audio MP3 and wav and converts them to the PCM 48 kHz 16 bit format which is used by the smartVES system. In addition, we can attribute an individual name to the added audio file ([Message Name](#)), which will enable its identification within the system. The [Global](#) option – means that a message will be saved on the memory cards of all available units in the system. The [Local Copy](#) option – clicking [Copy](#) will result in saving the original audio file (prior to its conversion into PCM) in the Workspace folder. [Replace File](#) – this is used to replace a selected audio file with another one.

The  serves to delete all messages held on the list.

The  is used to hear audio files on a computer on which the configuration software is installed, before these are loaded into the system.

4 Volume

Adjusting the playing volume of audio messages. Selector before converting audio file to the pcm format changes the volume by defined value. Any changes in level cause that the file must be re-sent to the system.

5 PSM's settings

[PSM's settings](#) is a field that must be filled carefully. Enter the number of Power supply managers directly connected via RS485 to the control unit by ABT-ISLE module. The declaration of the amount of PSMs connected to the control unit is required for correct reporting of the errors from managers and power supplies, which are supervised by the them.

13.3.7 SMART-AMAP-6 concentrator and SMART-DU-1604 processor

Recreate topology

When the topology is read, in addition to the typical system components visible, the following must necessarily be included: the SMART-DU-1604 processor and AMAP-6 concentrator(s).

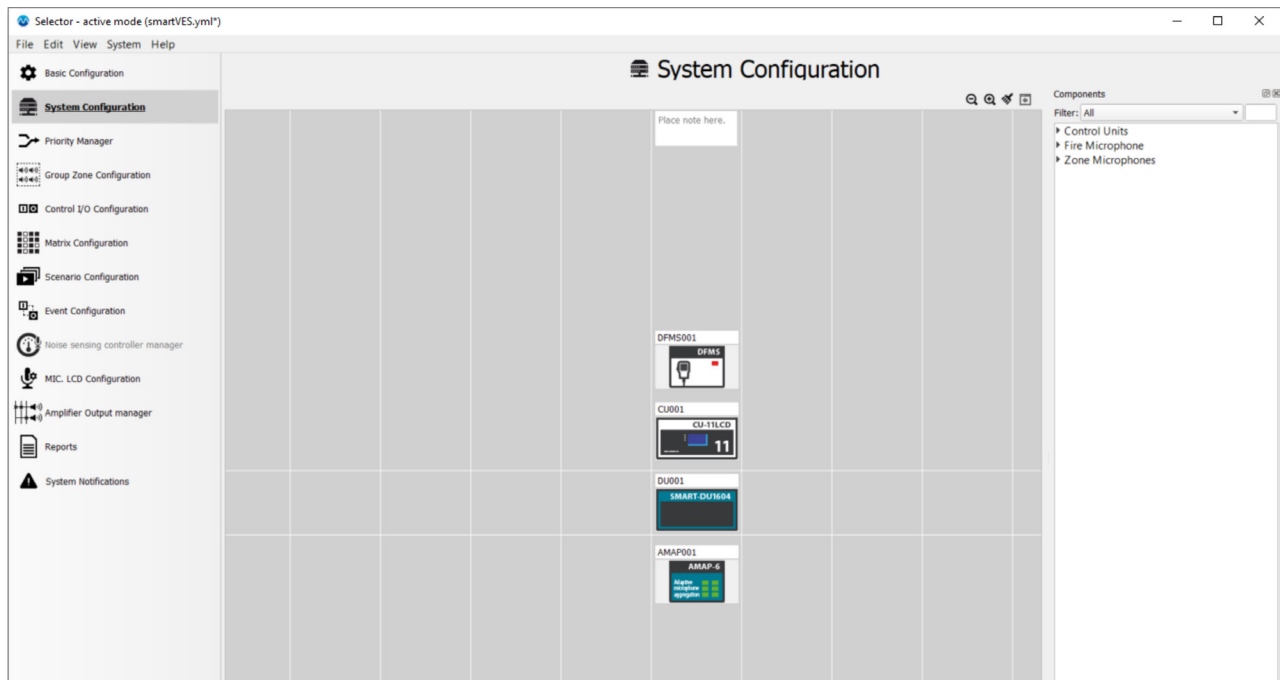

Configuration of the AMAP-6 concentrator

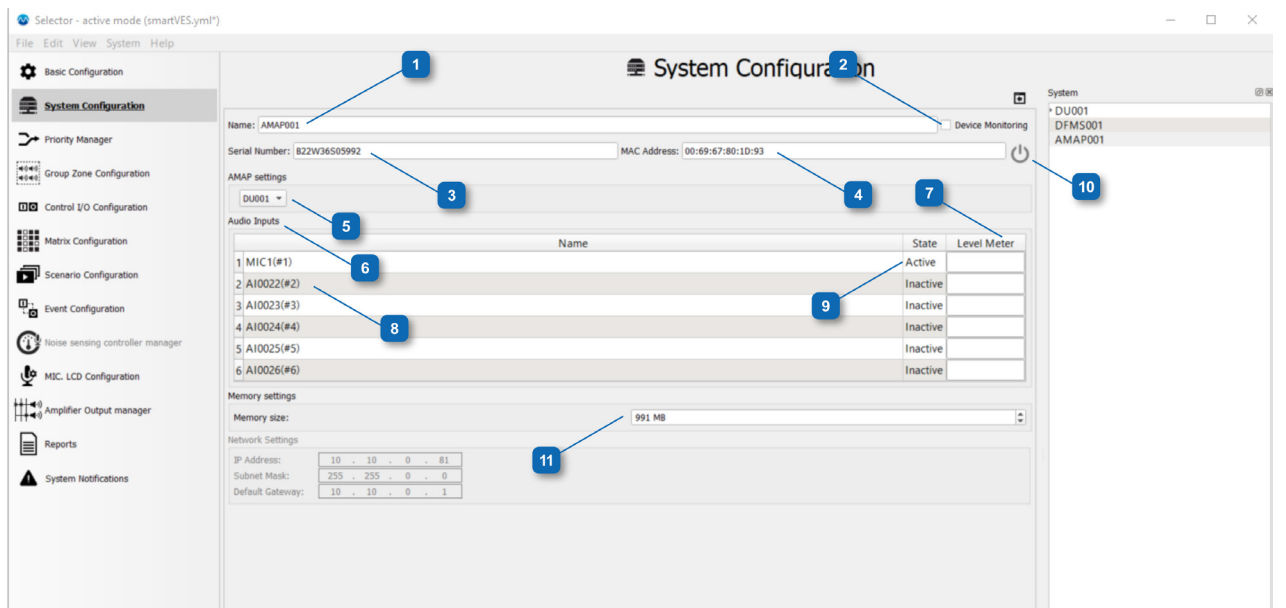

After double-clicking on the AMAP-6 hub icon, the following settings are available:

- 1 Name**
A field in which the name of the concentrator is generically assigned.
- 2 Device monitoring**
A function that allows the monitoring of the connection to the AMAP-6 concentrator (when the checkbox is selected, in the event of no communication with AMAP-06, the system will report this as a fault).
- 3 Serial number**
Field with the serial number of the AMAP-6 concentrator, which is visible after reading the topology of the devices.
- 4 MAC address**
Field with the MAC address of the AMAP-6 concentrator, which is visible after reading the topology of the devices.
- 5 AMAP settings**
Assignment of the AMAP-06 concentrator to a specific SMART-DU-1604 processor.
- 6 Audio inputs**
We name **8** each ANSM-01 microphone connected to the concentrator and set the status **9** to *Active*.
- 7 Level meter**
Graphical visualisation of the audio signal level. Once the configuration has been sent to the system, it is possible to activate the *online mode* **10** and monitor the audio level received by the ANSM-01 microphones.
- 8 Audio input / Name edit box**
Possibility to change the generically assigned name of the ANSM-01 microphone.
- 9 Status**
Activation/deactivation box for the ANSM-01 microphone.
- 10 Online mode**
Online mode for viewing the audio signal received by each connected microphone (active after system programming).
- 11 Memory size**
Field indicating the size of the memory card installed in the module. This value is automatically taken after reading the system topology.

SMART-DU-1604 processor configuration

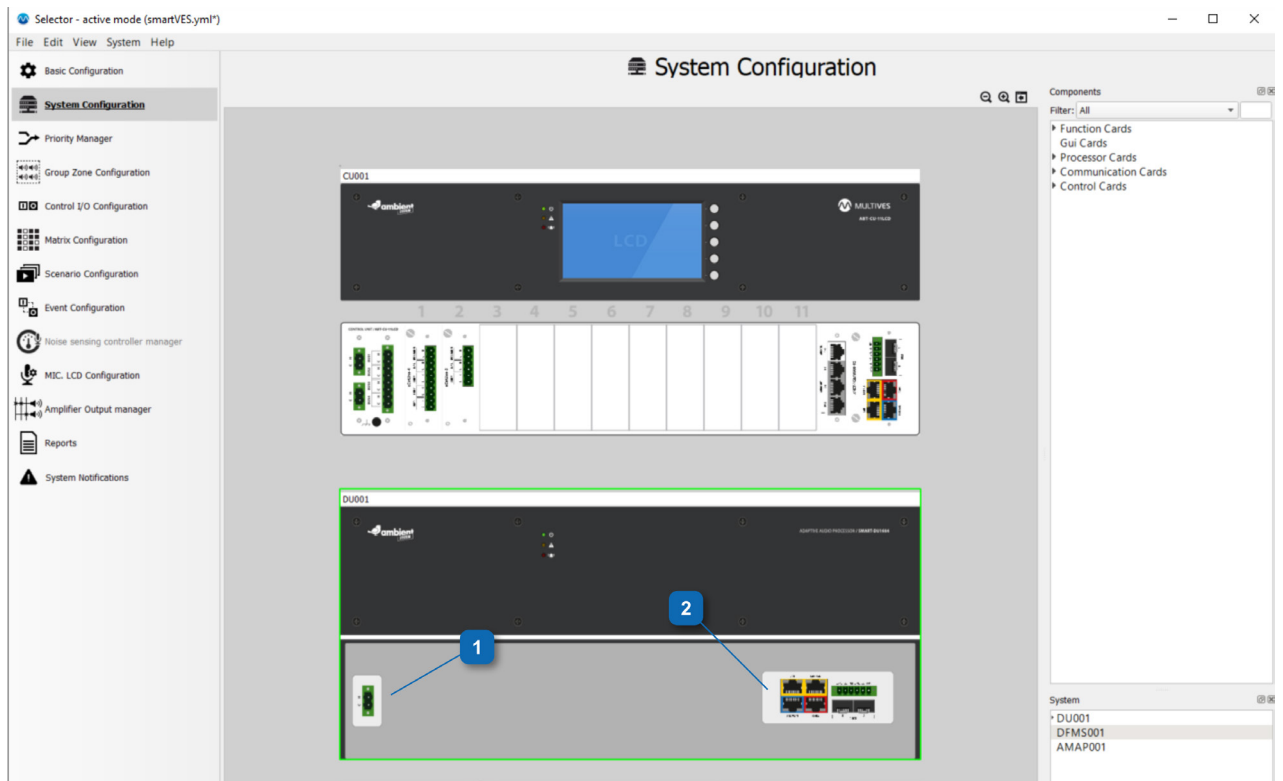

The SMART-DU-1604 processor configuration card is activated by double-clicking in the power connector field **1**.

Name: DU001

Serial Number: B23W23502714 MAC Address: 00:69:67:80:23:D7

DSP unit settings

SPL: 75 dB SNR: 12 dB Adaptation Time: 1,50 s

Audio Inputs

Pairing Calibrate All Zones

	Name	State	Bypass	Zones	Define AMAP	Verify	Calibrate	STI / SPL CAL	Fail Safe	SPL Meter
1	DU_IN_1(#1)	Active	Bypass	Assigned	AMAP001.ANSM_1	Not Verified	Channel 1	0.65 / 84	Params saved	0 dB
2	AI0005(#2)	Inactive	Bypass	Empty	Not Defined	Not Verified	Channel 2	0.00 / 0	Save Params	0 dB
3	AI0006(#3)	Inactive	Bypass	Empty	Not Defined	Not Verified	Channel 3	0.00 / 0	Save Params	0 dB
4	AI0012(#4)	Inactive	Bypass	Empty	Not Defined	Not Verified	Channel 4	0.00 / 0	Save Params	0 dB
5	AI0013(#5)	Inactive	Bypass	Empty	Not Defined	Not Verified	Channel 5	0.00 / 0	Save Params	0 dB
6	AI0014(#6)	Inactive	Bypass	Empty	Not Defined	Not Verified	Channel 6	0.00 / 0	Save Params	0 dB
7	AI0015(#7)	Inactive	Bypass	Empty	Not Defined	Not Verified	Channel 7	0.00 / 0	Save Params	0 dB
8	AI0016(#8)	Inactive	Bypass	Empty	Not Defined	Not Verified	Channel 8	0.00 / 0	Save Params	0 dB
9	AI0017(#9)	Inactive	Bypass	Empty	Not Defined	Not Verified	Channel 9	0.00 / 0	Save Params	0 dB
10	AI0018(#10)	Inactive	Bypass	Empty	Not Defined	Not Verified	Channel 10	0.00 / 0	Save Params	0 dB
11	AI0019(#11)	Inactive	Bypass	Empty	Not Defined	Not Verified	Channel 11	0.00 / 0	Save Params	0 dB
12	AI0020(#12)	Inactive	Bypass	Empty	Not Defined	Not Verified	Channel 12	0.00 / 0	Save Params	0 dB
13	AI0021(#13)	Inactive	Bypass	Empty	Not Defined	Not Verified	Channel 13	0.00 / 0	Save Params	0 dB
14	AI0022(#14)	Inactive	Bypass	Empty	Not Defined	Not Verified	Channel 14	0.00 / 0	Save Params	0 dB
15	AI0023(#15)	Inactive	Bypass	Empty	Not Defined	Not Verified	Channel 15	0.00 / 0	Save Params	0 dB
16	AI0024(#16)	Inactive	Bypass	Empty	Not Defined	Not Verified	Channel 16	0.00 / 0	Save Params	0 dB

Network Settings

- 1 Name**
A field in which the name of the processor is generically assigned.

- 2 Serial number**
Field with the serial number of the processor, which is visible after reading the topology of the devices.
- 3 MAC address**
Field with the MAC address of the processor, which is visible after reading the topology of the devices.
- 4 DSP unit settings**
Definition of the acoustic parameters ([SPL](#), [SNR](#)) to be achieved by the processor in a defined period of time ([Adaptation Time](#)).
▲ Please note that in acoustic zones that are classified as difficult, it may not be possible to achieve the high acoustic parameters.
- 5 Audio inputs**
A set of parameters related to the audio inputs of the DU processor.
- 6 Name**
DU processor selection.
- 7 Status**
Determining the status ([Active / Inactive](#)) of the audio input.
- 8 Bypass**
Exclusion of the audio path from the active control of the DU processor.
- 9 Zones**
Declaration of the loudspeaker zones operated by the respective audio path of the DU processor and the ANSM-01 microphone.
- 10 Defined**
Selection of the ANSM-01 microphone connected to the AMAP-6 concentrator.
- 11 Verification**
Field indicating the pairing (verification) status of the connected ANSM-01 microphone in the declared acoustic zone.
- 12 Calibration**
A box to start the calibration process for a single audio track of the DU processor.
- 13 Pairing**
Button to activate the pairing of all connected ANSM-01 microphones in the declared acoustic zones.
- 14 Calibration of all zones**
Box to start the calibration process for all audio tracks of the DU processor.
- 15 STI / SPL CAL**
Field informing about the values of the measured acoustic parameters:
[STI](#) - speech intelligibility index;
[SPL CAL](#) - sound pressure level.
- 16 Fail-safe parameters**
A function that activates the saving of the safe parameters that the DU processor will assume as default, when the connection with the AMAP-06 concentrator or the ANSM-01 microphone is lost.
- 17 Online mode**
A function that allows you to start reading out the parameters of the audio paths in real time ([function active after system programming](#)).

18 Sound Pressure Level

Presentation of the audio level in the respective audio path of the DU processor.

Verification of correct microphone selection and declared loudspeaker zone.

During this procedure, the SMART-DU-1604 processor will emit audio signals in the declared loudspeaker zones, which should be picked up by the declared measurement microphone.

To start the procedure, press the **Pairing** button **13**, and then confirm the operation in the pop-up window.

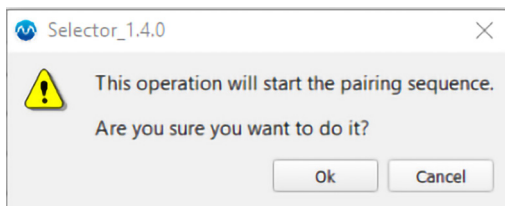

The pairing sequence will start.

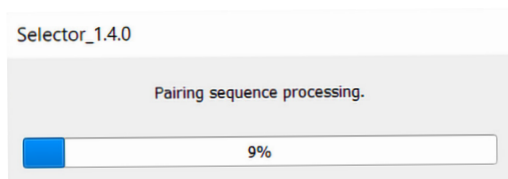

Completion of the pairing sequence will be confirmed by an appropriate message.

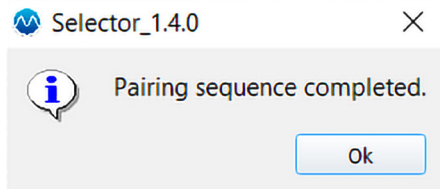

After confirming the notice, you will find the name of the paired (verified) microphone in the **Verification** column **10** highlighted in green.

Defined	Verification
AMAP.AMAP_MIC	AMAP.AMAP_MIC

Calibration of the DU processor's audio paths.

During calibration, the area(s) should be absolutely quiet so that the system can correctly read the acoustic conditions in the area. Calibration can be performed in two ways:

- » selectively, for individual audio inputs of the DU processor - **Channel x** button **12**;
- » globally, for all DU audio inputs - **Calibrate all zones** button **14**.

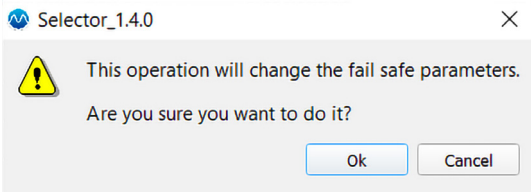

During calibration, the system will emit measurement signals to determine the acoustic conditions of the zones.

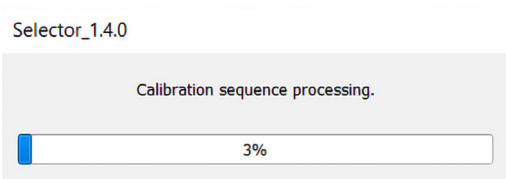

Completion of the calibration will be confirmed with an appropriate message.

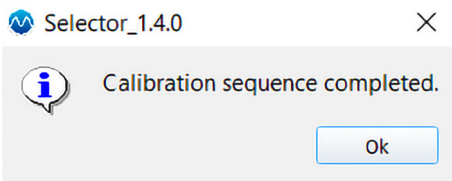

Fail-safe parameters

This function allows the calibration results to be saved as default acoustic conditions, in the event of no communication with the AMAP-6 Hub or the ANSM-01 microphone. The DU Processor will then rely on the stored values, without expecting a measurement from unavailable microphones connected to the concentrator.

After clicking on the [Save Parameters](#) button **16**, confirm the save start.

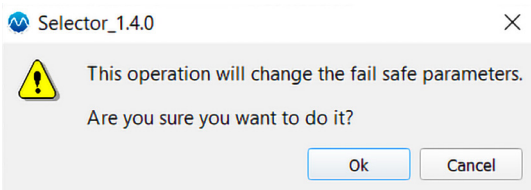

The correct completion of the parameters save, will be confirmed by an appropriate message.

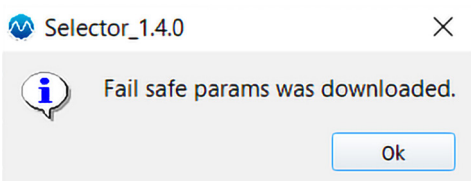

DU processor network card settings

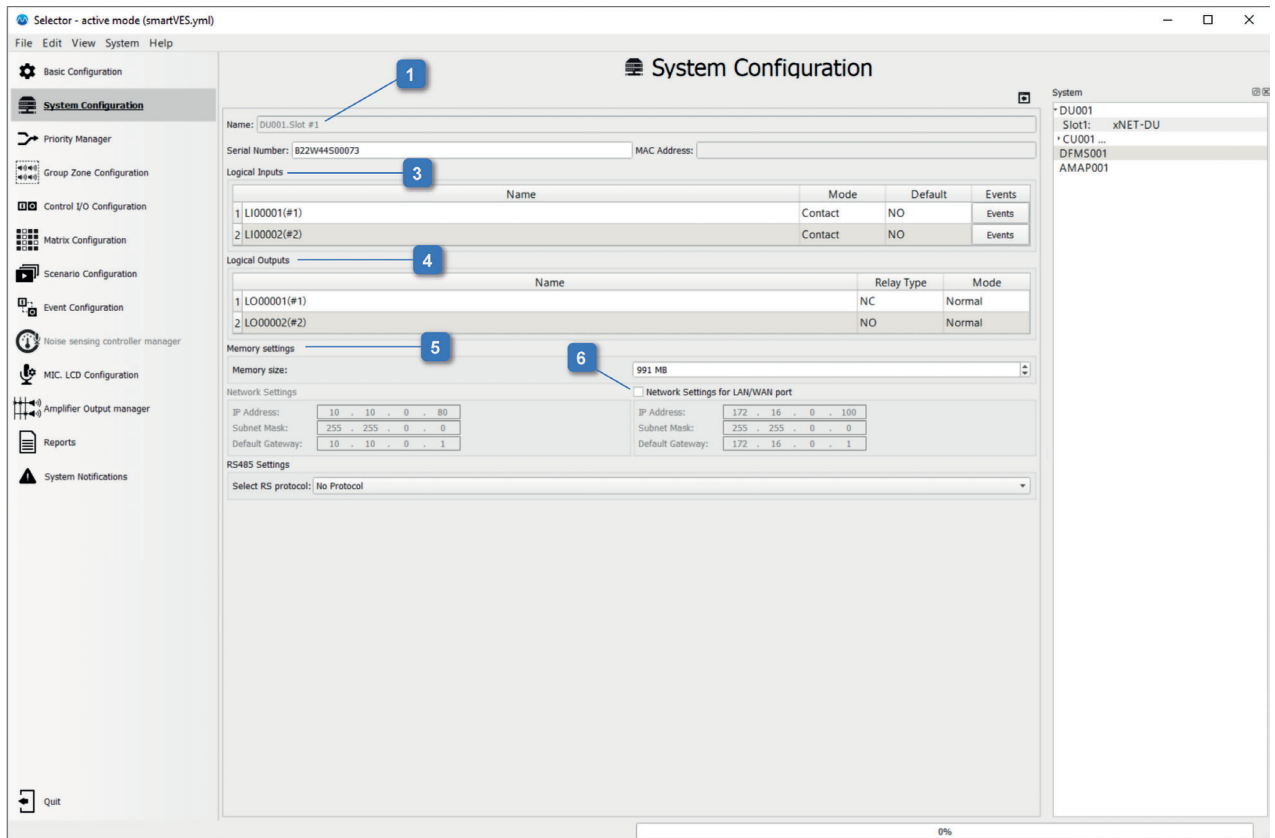

- 1 **Name**
 Field with the device name and slot number in which the network card of the DU processor is inserted.
- 2 **Serial number**
 Field with serial number of the xNET card.
- 3 **Logical inputs**
 The Logical Inputs field allows the configuration of the available logical inputs on the xNET card.
- 4 **Logical outputs**
 The Logical Outputs field allows the configuration of the available logical outputs on the xNET card.
- 5 **Memory settings**
 Field indicating the size of the memory card installed in the module. This value is automatically taken after reading the system topology.
- 6 **Network settings for the LAN/WAN port**
 Box for editing network parameters of the LAN/WAN port.

13.3.8 DFMS

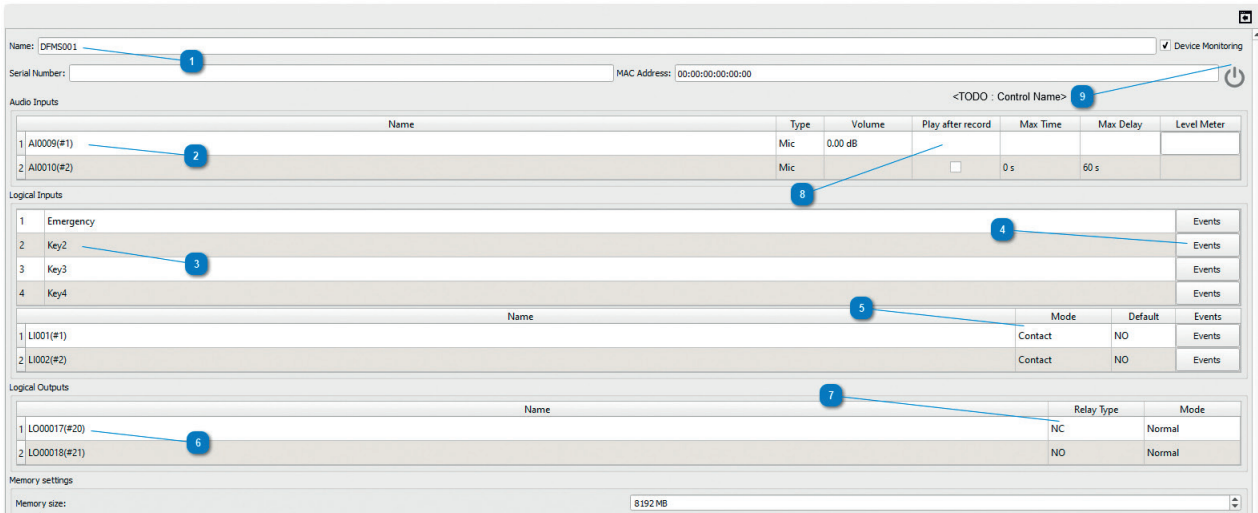

The screenshot shows the configuration interface for a DFMS001 device. It includes fields for Name, Serial Number, and MAC Address. Below these are sections for Audio Inputs, Logical Inputs, and Logical Outputs, each with a table of configurations. Callouts 1-9 highlight specific elements: 1 (Name field), 2 (Audio Input 1), 3 (Logical Input Key2), 4 (Events button for Key2), 5 (Mode/Default dropdown for LI001), 6 (Logical Output LO0017), 7 (Relay Type dropdown for LO0017), 8 (Volume field for Audio Input 1), and 9 (Device Monitoring checkbox).

1 Name

The name field enables assignment of an individual name to the fireman microphone, other than the generic name assigned by the configurator.

2 Audio Inputs

The **Audio Inputs** field contains all available audio inputs on the DFMS microphone. Item 1 is the microphone used only in the **Alarm** mode – as the standard setting, the input at Item 1 always has the highest priority of 0 (see the [Priority Manager](#) tab – the fireman microphone may have priorities assigned from the range 0-99). Item 2 is the same physical microphone as in Item No 1, however with a General-type priority (200-299). The Item 2 microphone is used to transmit ordinary messages in the smartVES system, e.g. Public Address. Double-clicking the name of the audio input enables to change the generic name assigned by the configurator.

3 Logical Inputs

The **Logical Inputs** tab contains all available buttons as well as logical inputs on the fireman microphone. A double click on the name of a button / logical input enables to change the generic name assigned by the configurator.

4 Events

The **Events** buttons transfers the programmer directly to the [EventConfiguration](#) tab. This enables to assign any function or event group to a selected button. A right-click on the name of a button / logical input in the [EventConfiguration](#) tab, as well as selection of [Go to definition](#), enables to return quickly to the editing menu of the fireman microphone.

5 Mode / Default

The logical input editing window enables activation of the input monitoring function – **Mode Contact** / **Monitor**. In case the **Monitor** option is selected, it is necessary to install two parametrizing resistors at the end of the line, of 4.7 kΩ.

In the window **Default**, we select the input status for inactivity for the **NC** option the system anticipates a closed circuit on the input, opening results in activation of the function assigned in [EventConfiguration](#). For **NO** the situation is reverse: the system anticipates an open circuit on the input, closing results in activation of the assigned function.

6 Logical Outputs

The **Logical Outputs** tab contains all available logical (relay) outputs on the fireman microphone. A double click on the name of a logical output enables to change the generic name assigned by the configurator. Assigning a function to a chosen relay is possible in the [EventConfiguration](#) – select an input event, assign a general function and click [Add control outputs](#) action (the circle in a square icon ).

7 Relay Type / Mode

Relay type is a window to inform of the physical type of the relay installed. **NC** – normally closed, in case of a power cut, the relay will be closed, **NO** – normally open, in case of a power cut, the relay will be open.

The **Mode** window enables to reverse the relay logic, opposite to its behaviour in case of a power cut. The **Inverse** causes, e.g., that the relay **NC / Inverse**– in the original status it is a NO relay, and activation of the function to which it is assigned will change the status of the relay into the opposite one, i.e. NC. For **NC / Normal** in the original status (not triggered by any function) the relay is closed, activation of the function, as assigned to this output, causes that the relay status changes into the opposite one, i.e. open. The values from the windows **Relay Type** and **Mode** are also duplicated in the information window below **Scenario State** and in the **EventConfiguration** tab the function **General – Logical Outputs**, also in the information window below **State**.

8 Audio input options

Activating the **play after record** option allows recording up to 40 s of a message being transmitted by the ABT-DFMS and playing it back immediately after releasing the PTT button.



	Name	Type	Volume	Play after record	Max Time	Max Delay	Level Meter
1	A 0037(#1)	Mic	0.00 dB				
2	A 0038(#2)	Mic		<input checked="" type="checkbox"/>	40 s	0 s	

Max time – sets the length of recorded message.

Max delay – sets the longest time the system will wait for the intended transmission zone to be freed. After the set time the message will be played back from the buffer. If the operator chooses to transmit to more than one zone, the system will play the message in all the available / free zones after the set delay time has passed and erase the message from the buffer.

	Name	Type	Volume	Play after record	Max Time	Max Delay	Level Meter
1	A 0037(#1)	Mic	0.00 dB				
2	A 0038(#2)	Mic		<input type="checkbox"/>	40 s	60 s	

9 On-line mode

The online mode offers the user the possibility to view the audio level meter in real time and to adjust the mic volume level. After uploading the configuration into the system, you can enter the on-line mode by clicking the icon  – it will then change it's color to green indicating active on-line mode .



DFMS editing window – continued

1 Extension Configuration

In this window the user declares the number of connected extensions. The maximum of 5 supervised extensions with 20-buttons can be connected to the microphone. Respectively to the selected number of extensions, the configuration window will extend to include the field for additional button name editing and ability to assign a function using the **Events** button. The extended editing field is shown below:

Ext1	Ext2	Ext3	Ext4	Ext5	
5	Key5	Events	15	Key15	Events
6	Key6	Events	16	Key16	Events
7	Key7	Events	17	Key17	Events
8	Key8	Events	18	Key18	Events
9	Key9	Events	19	Key19	Events
10	Key10	Events	20	Key20	Events
11	Key11	Events	21	Key21	Events
12	Key12	Events	22	Key22	Events
13	Key13	Events	23	Key23	Events
14	Key14	Events	24	Key24	Events

Extensions connected to the fireman's microphone are visible after downloading the topology from the system.

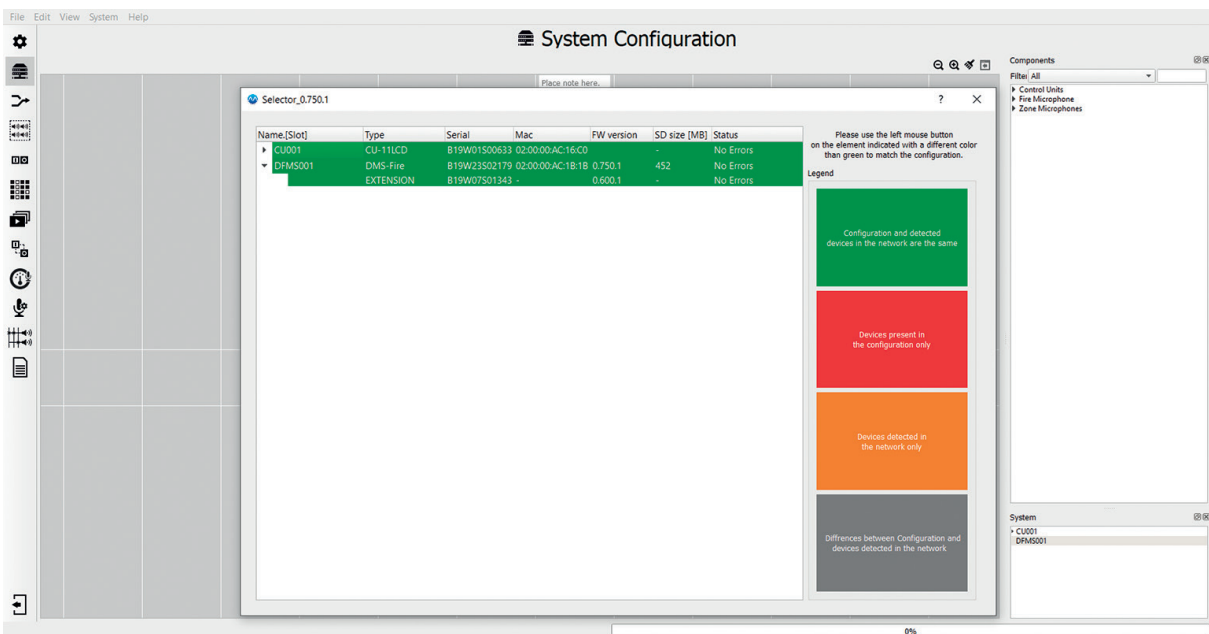

2 Fireman Microphone Configuration

The fireman microphone [PTT button](#) function window. Apart from the [PTT](#) – Push to talk mode in the [Mode](#) option, there is a possibility to select [LOCK](#), i.e. having pressed the PTT button, the microphone is active for the time defined in the [Lock Timeout](#) window. The maximum microphone activation time is 60 seconds.

The [Start Gong](#) option – this enables the gong having pressed the PTT button; [End Gong](#) will be activated after the PTT button is released.

3 Network Settings

This is the address which will be assigned to a physical device having loaded a configuration into the system. Changing IP addresses assigned by the configurator is not recommended.

13.3.9 DMS

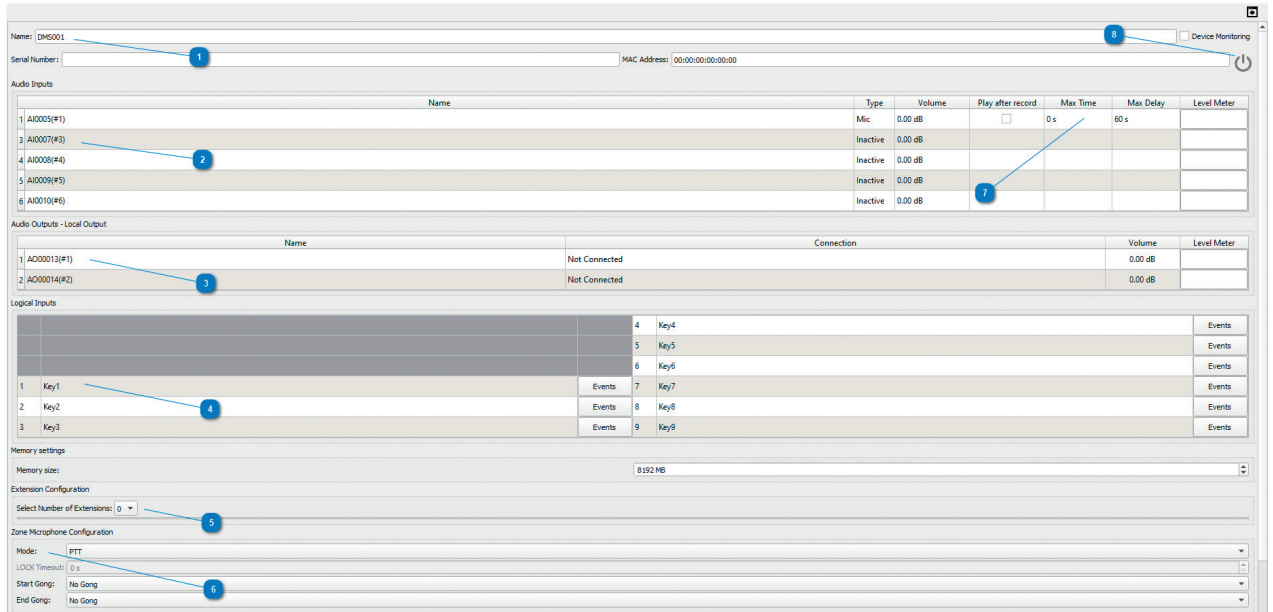

1 Name

This field enables to assign an individual name to the DMS microphone, other than the generic name assigned by the configurator.

2 Audio Inputs

The **Audio Inputs** field contains all available audio inputs in the zone microphone. Item 1 on the above figure, is a gooseneck condenser microphone – connected to the built in XLR socket.. As standard, adding a zone microphone sets the gooseneck microphone using the built in XLR as activates the main microphone. Item 2 is a jack TRS 3.5 mm type socket located on the ABT-DMS rear panel, intended for electret microphones. The system automatically detects a microphone connected to the TRS jack and disconnects the built in XLR in this event. Items 3,4,5,6 are four unbalanced linear audio inputs. Available via 3,5 mm TRS jack sockets. In one jack 3,5mm socket we have access to 2 channels – Tip: Channel 1+, Ring: Channel 2+, Sleeve 1,2. In order to activate the input, in the **Type** window change the value **Inactive** into **Line IN** on the selected input which we want to activate. Double-clicking the name of the audio input enables to change the generic name assigned by the configurator.

3 Audio Outputs – Local Output

Each zone microphone is equipped with two audio outputs. Item 1 is an output directly connected to the internal amplifier of the built-in speaker. Item 2 is a linear output, socket type TRS. Tip: out2+, Ring: out2+, Sleeve 2-. In order to activate the output, in the **Connection** window change the value from **Not connected** into **Line output**. An activated output is shown as a separate subzone in the system.

4 Logical Inputs

The **Logical Inputs** tab contains all available buttons on a zone microphone. A double click on the name of a button enables to change the generic name assigned by the configurator. The **Events** buttons transfers the programmer directly to the **EventConfiguration** tab. This allows to assign any function or event group to a selected button. A right-click on the name of a button / logical input in the **EventConfiguration** tab, as well as selection of **Go to definition**, enables to return quickly to the editing menu of the zone microphone.

5 Extension Configuration

In this window the user declares the number of connected extensions. The maximum of 5 20-button extensions can be connected to the microphone. Respectively to the selected number of extensions, the configuration window will extend to include the field for additional button name editing and ability to assign a function using the [Events](#) button. The extended editing field is shown below:

Logical Inputs						
				4	Key4	Events
				5	Key5	Events
				6	Key6	Events
1	Key1	Events		7	Key7	Events
2	Key2	Events		8	Key8	Events
3	Key3	Events		9	Key9	Events

Extensions connected to the fireman's microphone are visible after downloading the topology from the system.

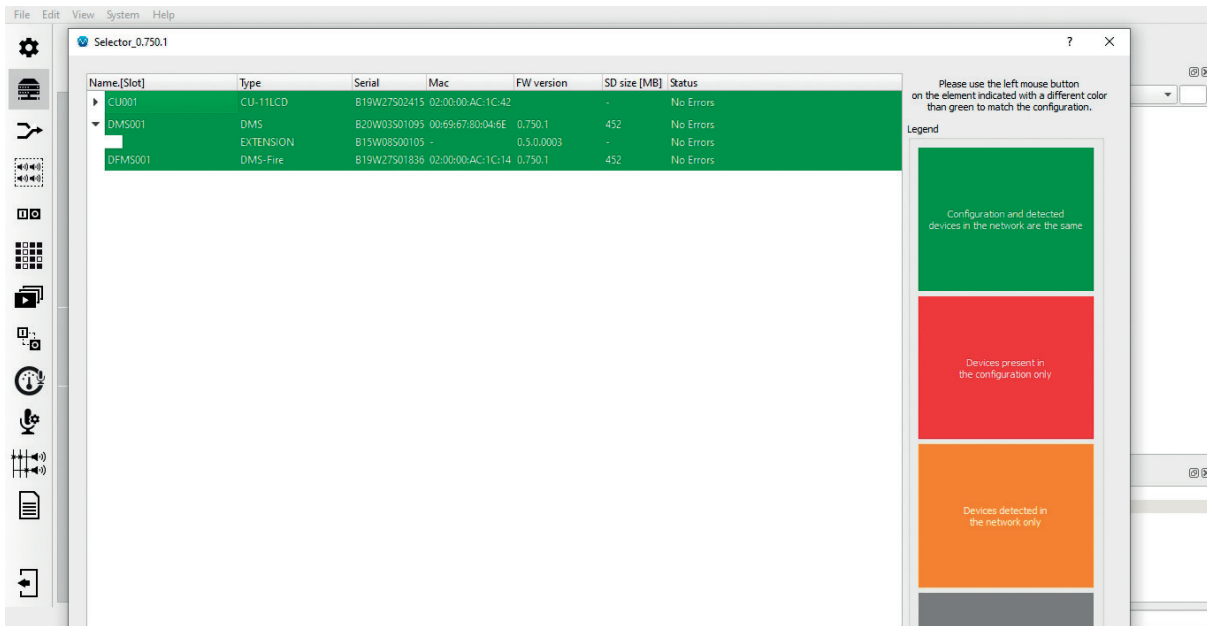

The screenshot shows a software window titled "Selector_0,750.1" with a menu bar (File, Edit, View, System, Help) and a toolbar on the left. The main area contains a table with the following data:

Name.[Slot]	Type	Serial	Mac	FW version	SD size [MB]	Status
CU001	CU-11LCD	B19W27502415	02:00:00:AC:1C:42	-	-	No Errors
DMS001	DMS	B20W03501095	00:69:67:80:04:6E	0.750.1	452	No Errors
	EXTENSION	B15W08500105	-	0.5.0.0003	-	No Errors
DFMS001	DMS-Fire	B19W27501836	02:00:00:AC:1C:14	0.750.1	452	No Errors

To the right of the table is a legend with three colored boxes:

- Green:** Configuration and detected devices in the network are the same.
- Red:** Devices present in the configuration only.
- Orange:** Devices detected in the network only.

Instructions above the legend state: "Please use the left mouse button on the element indicated with a different color than green to match the configuration."

6 Zone Microphone Configuration

The dedicated section for PTT button is placed on the front panel of the zone microphone function window. Apart from the [PTT](#) mode – Push to talk in the [Mode](#) option, there is a possibility to select [LOCK](#), i.e. having pressed the PTT button, the microphone is active for the time defined in the [Lock Timeout](#) window. The maximum microphone activation time is 60 seconds. The [Start Gong](#) option – this enables activation of the gong having pressed the PTT button; [End Gong](#) will be activated after the PTT button is released.

Zone Microphone Configuration	
Mode:	PTT
LOCK Timeout:	0 s
Start Gong:	No Gong
End Gong:	No Gong
Delay:	0 ms

7 Audio input options

Activating the [play after record](#) option allows recording up to 40 s of a message being transmitted by the ABT-DMS and playing it back immediately after releasing the PTT button.



	Name	Type	Volume	Play after record	Max Time	Max Delay	Level Meter
1	AI0037(#1)	Mic	0.00 dB				
2	AI0038(#2)	Mic		<input checked="" type="checkbox"/>	40 s	0 s	

Max time – sets the length of recorded message.

Max delay – sets the longest time the system will wait for the intended transmission zone to be freed. After the set time the message will be played back from the buffer. If the operator chooses to transmit to more than one zone, the system will play the message in all the available / free zones after the set delay time has passed and erase the message from the buffer.

	Name	Type	Volume	Play after record	Max Time	Max Delay	Level Meter
1	AI0037(#1)	Mic	0.00 dB				
2	AI0038(#2)	Mic		<input type="checkbox"/>	40 s	60 s	

8 On-line mode

The online mode offers the user the possibility to view the audio level meter in real time and to adjust the mic volume level. After uploading the configuration into the system, you can enter the on-line mode by clicking the icon  – it will then change it's color to green indicating active on-line mode .

13.3.10 DMS-LCD

The DMS-LCD microphone has the same configuration window as the DMS microphone. The only exception being that, to set up the messages and zones visible on the LCD touch panel you should go to the [DMS-LCD configuration](#) tab on the left side of the screen menu bar .

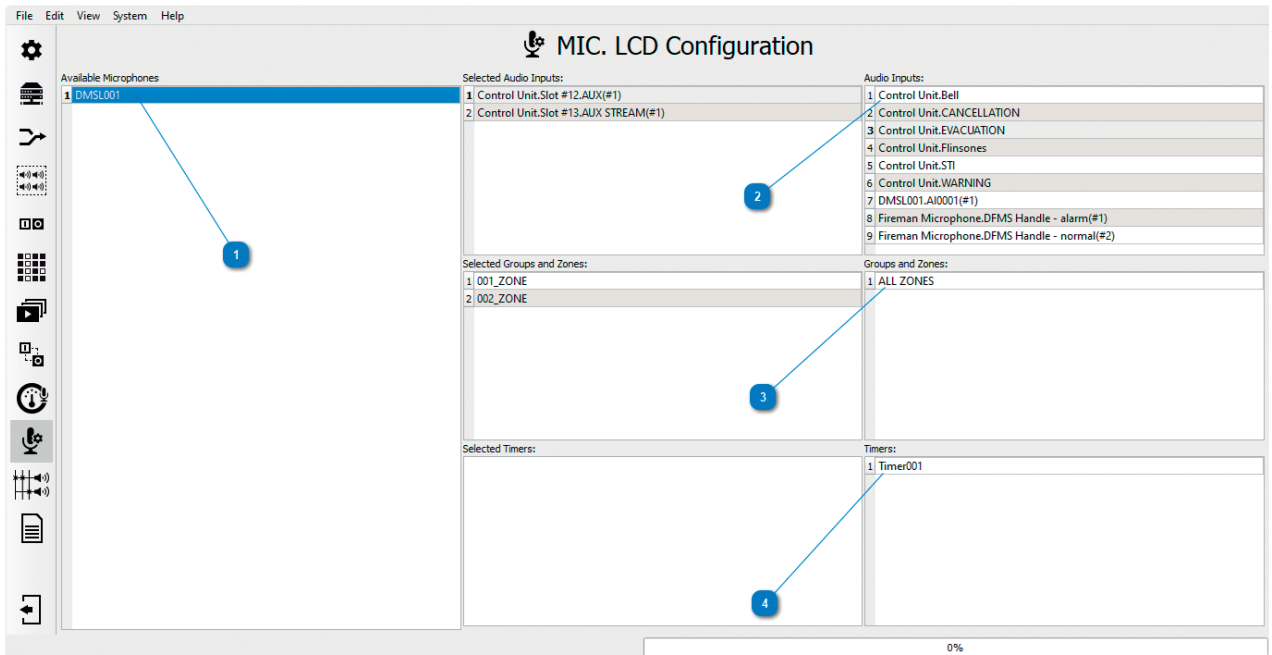

1 Available Microphones

A list of available DMS-LCD microphones in the system. Every microphone can have individually programmed access to audio inputs and zones.

2 Audio inputs

A list of defined audio sources / messages available in the smartVES system. A double-click on the chosen input source will transport it to the [Selected Audio Inputs](#) field and add it to the DMS-LCD microphone touch screen menu.

3 Groups and zones

A list of defined audio outputs / zones available in the smartVES system. A double-click on the chosen output transports it to the [Selected Groups and Zones](#) field and add it to the DMS-LCD microphone touch screen menu.

4 Timers

A list of defined timers available in the smartVES system. A double-click on the chosen output transports it to the [Selected Timers](#) field and add it to the DMS-LCD microphone touch screen menu.

13.3.11 NCS6 Configuration

Connection and configuration

The ABT-NSC6 module is a Noise Sensing Controller and is used to automatically adjust the volume of the signal in relation to the sound pressure level of the ambient noise in the desired area.

The ABT-NSC6 module connects to the rest of the system using an Ethernet cable as standard TIA / EIA-568-B and the LAN or LAN / POE port, its further configuration is carried out in the Selector software.



Two types of noise sensing microphones are available, compatible with the ABT-NSC6 module:

- » ABT-NSM1
- » ABT-NSM2

NSC6 configuration panel allows to assign one or many Noise Sensing Microphones to one zone or group of zones. In this area output levels together with number of microphone thresholds can be also defined (from 1 to 10).

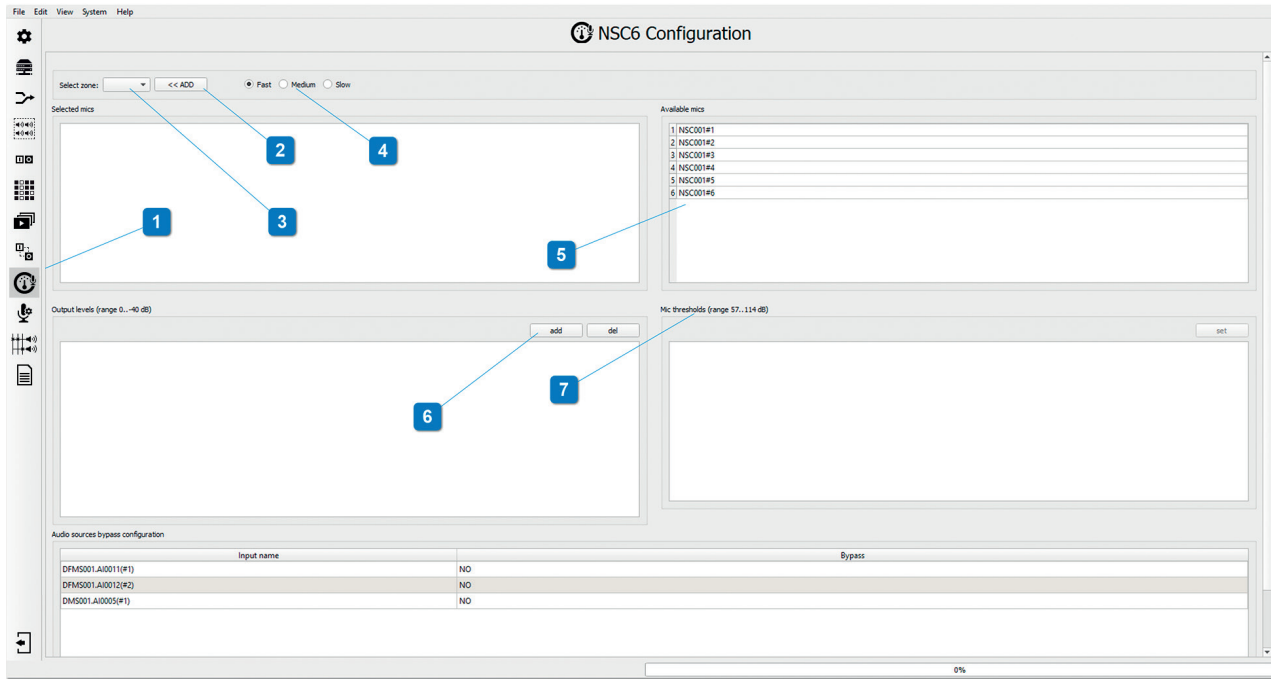

1 The **NSC6 Configuration** icon is used to open configuration window background microphone controller ABT-NSC6.

2 

To start NSC6 configuration process assigning of NSC to desired zones has to be made. To do this **<<ADD** has to be pressed. Then, dedicated window with available zones will be displayed. To select zones, which will be controlled by NSC please double-click on **NO** in Selected column to switch it to **YES** value.

After selection window can be closed with **x** sign or **Close** button.

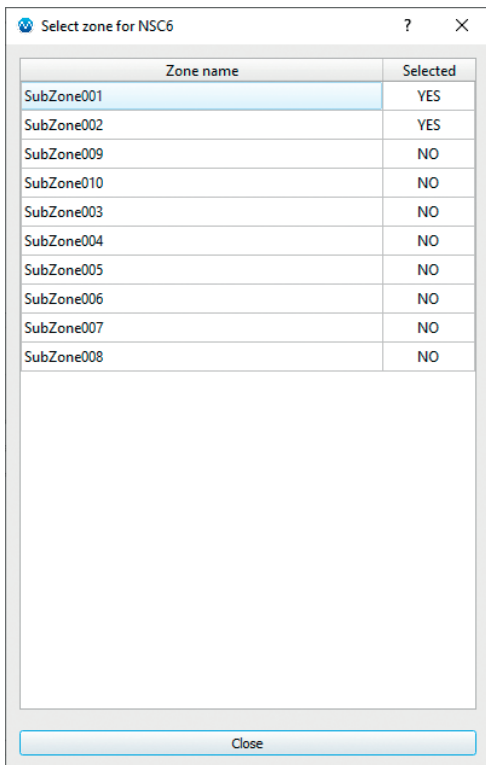

3 Select zone SubZone001

After zone selection process described above, next step is to select from drop-down list Zone or Group which detailed settings will be defined in next step.

- SubZone001
- SubZone002
- SubZone003
- SubZone004

4 Fast Medium Slow

Each volume change on zone or group can be defined with own reaction time for ambient sound pressure level change. Three modes are available: Fast, Medium, Slow. Each of those modes define reaction time for rising Edge (UP) and falling Edge (DOWN). Values in seconds are shown below:

	UP	DOWN
FAST	2	4
MEDIUM	5	10
SLOW	10	20

The selection is made for each selected zone separately.

5 Available mics

- 1 NSC001#2
- 2 NSC001#3
- 3 NSC001#4

It is needed to assign at least one NSC microphone input to zone, which will be controlled. In this possible to assign up to 6 NSC inputs to single zone – in this case triggering threshold limit by one of microphones will result in volume change on controlled zone.

To assign NSC microphone:

- › select zone from drop-down list
- › by double LMB click select in column **Available mics** desired inputs, that will be used for volume adjustments.

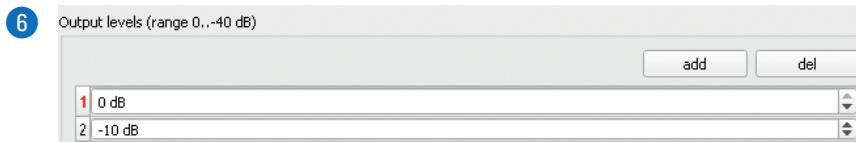

Next stage is to define number and

It is possible to define up to 10 levels. Changing number of levels is done by **ADD** and **DEL** buttons. Each of those levels can be adjusted by 1dB with up and down arrows.

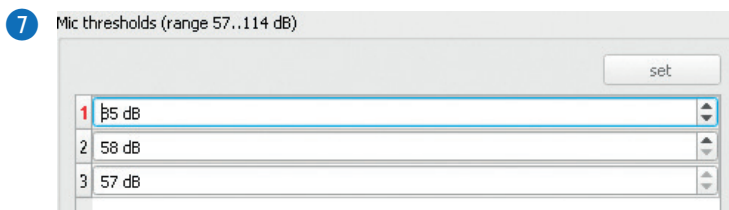

Number of Thresholds is directly connected with number of Output levels parametrized in step before. Number of Thresholds equals number of Output levels -1.

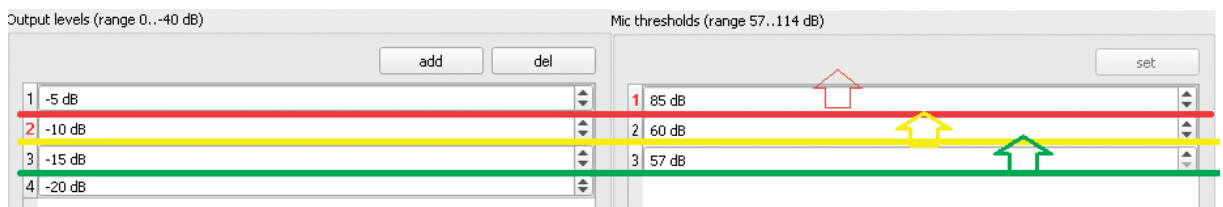

On above example principle of work of NSC is shown. If measured ambient sound pressure level is below 57dB (green line) then output volume will be attenuated by -20dB. When SPL will be between 58 and 60dB then output volume will be attenuated by -15dB. When SPL will be above 85dB then output volume will be attenuated by -5dB.

Both Output Levels and Mic Thresholds can be individually defined.

NSC is active all time, when system is broadcasting messages or is in standby.

NOTICE: To measure the ambient noise level live, go to the **System Configuration** tab, in the topology view, double-click NSC6 module, enable **ON-LINE**  mode, then read the sound pressure values that will be displayed on the right of the microphone input fields. Observe the maximum and minimum SPL received by NSC microphones and use these values as the maximum and minimum microphone thresholds.

- 8
- List of audio sources in which **Bypass** can be activated and volume control disabled for these sources. To do this, double-click the **NO** icon in **Bypass** column.

Changing to the **YES** form confirms activation of bypass.

Audio sources bypass configuration

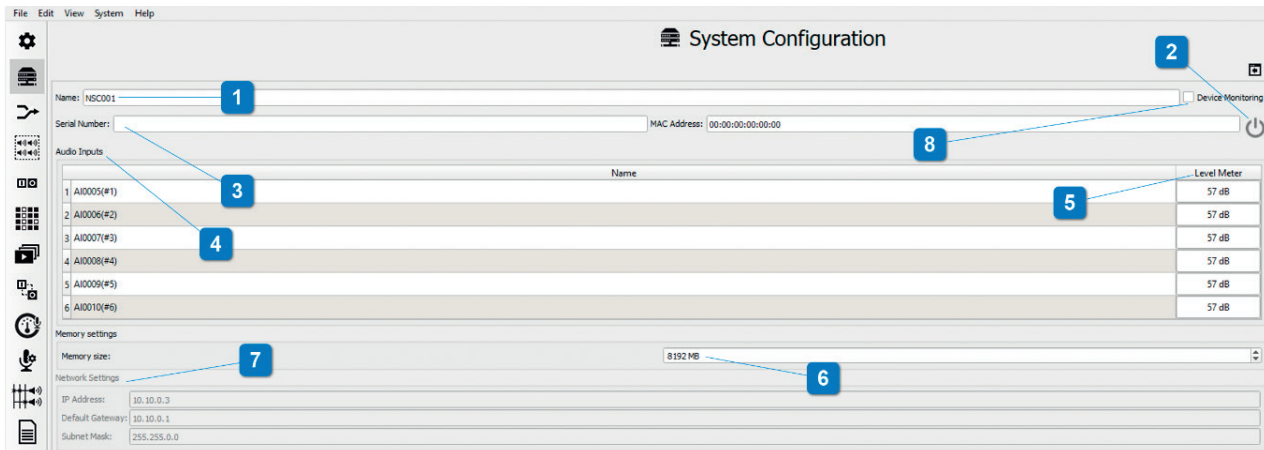

Input name	
DFMS001.AI0005(#1)	YES

Further configuration is possible by double-clicking NSC6 module in system topology window.



1 Name: NSC001

The Name field allows you to give an individual name to each NSC6 module.

2 On-Line mode allows you to view SPL values in the **Level Meter** column. When the system has an updated configuration and is active, clicking the gray icon  will activate the on-line mode, which will be confirmed by a change icon color to green . When online mode is active, the measured sound pressure value is displayed.

3 Serial Number: MAC Address: 00:00:00:00:00:00

The field with serial number and mac address is completed automatically after reading the system topology.

4 Audio Inputs

1 AI0005(#1)

Each NSC6 module has 6 inputs for ABT-NSM background microphones. The generic name of the input, e.g. AI0005, can be changed freely and symbol # with the number indicates number of physical input on PCB module.

5 Level Meter

57 dB

The value shown in the **Level Meter** column is measured value if online mode is active. This value is useful when setting thresholds for attenuation.

6 8192 MB

This field shows the physical capacity of the memory card.

7 Network Settings

IP Address:	10.10.0.3
Default Gateway:	10.10.0.1
Subnet Mask:	255.255.0.0

These fields present network parameters such as the IP address that will be assigned to the NCS6 controller. This is for informational purposes only and these values should not be changed manually.

8 Device Monitoring

Checking this box means that the NSC-6 module connection will be supervised.

13.3.12 xCtrLine-2/4/44

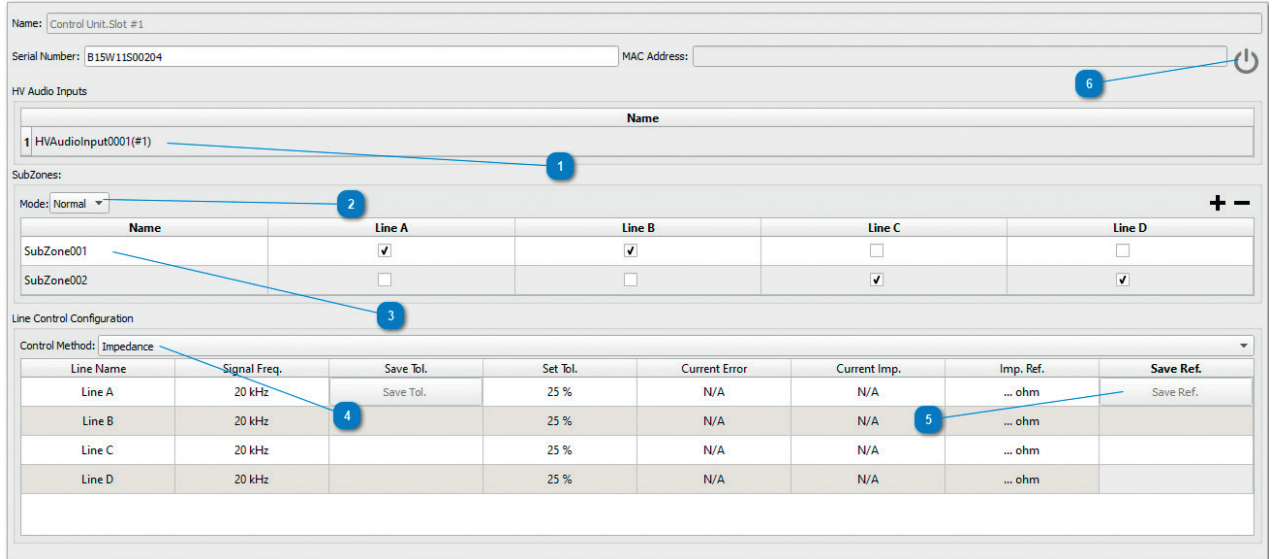

Name: Control Unit.Slot #1

Serial Number: B15W11S00204 MAC Address:

HV Audio Inputs

Name	Line A	Line B	Line C	Line D
SubZone001	<input checked="" type="checkbox"/>	<input checked="" type="checkbox"/>	<input type="checkbox"/>	<input type="checkbox"/>
SubZone002	<input type="checkbox"/>	<input type="checkbox"/>	<input checked="" type="checkbox"/>	<input checked="" type="checkbox"/>

Line Control Configuration

Control Method: Impedance

Line Name	Signal Freq.	Save Tol.	Set Tol.	Current Error	Current Imp.	Imp. Ref.	Save Ref.
Line A	20 kHz	<input type="checkbox"/>	25 %	N/A	N/A	... ohm	<input type="checkbox"/>
Line B	20 kHz	<input type="checkbox"/>	25 %	N/A	N/A	... ohm	<input type="checkbox"/>
Line C	20 kHz	<input type="checkbox"/>	25 %	N/A	N/A	... ohm	<input type="checkbox"/>
Line D	20 kHz	<input type="checkbox"/>	25 %	N/A	N/A	... ohm	<input type="checkbox"/>

1 HV Audio Inputs

The name field enables to assign an individual name to the input intended to receive a 100 V signal from an amplifier output. The name is shown on the main Audio-4/12 editing window, in the [Connection](#) tab.

2 SubZones / Mode:

Mode enables switching the card into following modes: [Loop](#) – the system detects short circuit / open line as well as ground leakage; [Regulator](#) – the volume control mode on the speaker line.

3 SubZones

Speaker zone editing window. It enables changing of the generic name of a zone by double-clicking the name. In addition, it is possible to define which speaker line outputs (A,B,C,D) are assigned to a given zone. Any combination is possible, however the default settings are accordant with the EN54-16, EN54-4 standards and assign two outputs per each zone.



4 Line Control Configuration / Control Method:

Speaker line supervision method window – options include: [Impedance](#) method and [Switching off](#) the speaker line supervision.

5 Save Rev.

If the system is supposed to supervise speaker lines by means of the [impedance method](#), having loaded a configuration into the system and connected a speaker line of a properly matched power and free of ground faults, load the impedance reference for a given line. In order to do this, select the [Save REV](#) button. From now on, the system properly supervises the operation of the speaker line. The [impedance method](#) continuously measures the impedance of the speaker line and if the value set in the tolerance window has been exceeded, an error is reported. The [impedance method](#) is equipped with a number of algorithms to minimize reporting untrue faults resulting from abrupt temperature changes which affect line impedance, as well as sudden changes of impedance itself. Adequate impedance measurement range on a single speaker line starts at 12.5 Ω, and ends at 10 kΩ, for measured frequency of 20 kHz. A 4-output xCtrLine-4 card (A,B,C,D) can be loaded up to 800 W of total power, the maximum load for a single speaker line is 300 W. In the case of a bridged connection of outputs A+B and C+D, the maximum tolerated power for each pair is 450 W. for a 2-output xCtrLine-2 card (A,B), the correct impedance measurement range on a single speaker line is minimum 12.5 Ω, max 10k ohm, for the reference frequency of 20 kHz. A 2-output card can be loaded up to 400 W of total power, the maximum load for a single speaker line is 300 W. In the case of a bridged connection of outputs A+B and C+D, the maximum supported power for each pair is 450 W.

6 On-line mode

The on-line mode enables to view the impedance values, as measured, as well as record reference impedance into the control card. Having loaded a configuration into the system, a single click on the left mouse button on the grey icon  results in entering the real-time view mode and change of the colour of the icon into bright green . A change of tolerance, reference impedance or real-time measurement must be preceded by entering into the on-line mode.

13.3.13 xLogIN-8c/f

Name:

Serial Number: MAC Address:

Logical Inputs

	Name	Mode	Default	Events
1	LI00003(#1)	Contact	NO	Events
2	LI00004(#2)	Contact	NO	Events
3	LI00005(#3)	Contact	NO	Events
4	LI00006(#4)	Contact	NO	Events
5	LI00007(#5)	Contact	NO	Events
6	LI00008(#6)	Contact	NO	Events
7	LI00009(#7)	Contact	NO	Events
8	LI00010(#8)	Contact	NO	Events

1 Logical Inputs

The [Logical Inputs](#) tab contains all available logical inputs in the xLogIN-8 card. A double click on the name of a logical input enables to change the generic name assigned by the configurator.

2 Mode / Default

The logical input editing window enables activation of the input monitoring function – [Mode Contact](#) / [Monitor](#). In case the [Monitor](#) option is selected, it is necessary to install two parametrizing resistors at the end of the line, of 4.7 kΩ. In the window [Default](#), we select the input status for inactivity – for [NC](#) the system waits for closing on the input, opening results in activation of the function assigned in [Event Configuration](#); for [NO](#) the situation is reverse: the system waits for opening on the input, closing results in activation of the assigned function.

3 Events

The [Events](#) buttons transfers the programmer directly to the [Event Configuration](#) tab. This enables to assign any function or event group to a selected button. A right-click on the name of a button / logical input in the [Event Configuration](#) tab, as well as selection of [Go to definition](#), enables to return quickly to the xLogIN-8 editing menu.

13.3.14 xLogOUT-8c/f

Name: CU001.Slot #11

Serial Number: B14W18S00064 MAC Address:

Logical Outputs

	Name	Relay Type	Mode
1	LO00003(#1)	NC	Normal
2	LO00004(#2)	NC	Normal
3	LO00005(#3)	NC	Normal
4	LO00006(#4)	NC	Normal
5	LO00007(#5)	NO	Normal
6	LO00008(#6)	NO	Normal
7	LO00009(#7)	NO	Normal
8	LO00010(#8)	NO	Normal

1 Logical Outputs

The [Logical Outputs](#) tab contains all available logical (relay) outputs on the xLogOUT-8 card. A double click on the name of a logical output enables to change the generic name assigned by the configurator.

2 Relay type / Mode

Relay type is a window to inform of the physical type of the relay installed:

[NC](#) – normally closed, in case of a power cut, the relay will be closed;

[NO](#) – normally open, in case of a power cut, the relay will be open.

The [Mode](#) window enables to reverse the relay logic, opposite to its behaviour in case of a power cut. The [Inverse](#) causes, e.g., that the relay [NC](#) / [Inverse](#) – in the original status it is a NO relay, and activation of the function to which it is assigned will change the status of the relay into the opposite one, i.e. NC. For [NC](#) / [Normal](#) in the original status (not triggered by any function) the relay is closed, activation of the function, as assigned to this output, causes that the relay status changes into the opposite one, i.e. open. The values from the windows [Relay Type](#) and [Mode](#) are also duplicated in the information window below [Scenario State](#) and in the [EventConfiguration](#) tab the function [General](#) – [Logical Outputs](#), also in the information window below [State](#).

The maximum loads of a single relay output are presented below:

Max VDC = 48 V | Max IDC = 500 mA | Max DC Power = 20 W

13.3.15 Audio-4/12

Name: CU002.Slot #12

Serial Number: MAC Address:

Audio Inputs

	Name	Type	Volume	Stereo	DSP
1	AI0010(#1)	Inactive	0.00 dB	<input type="checkbox"/>	Configure
2	AI0011(#2)	Inactive	0.00 dB	<input type="checkbox"/>	Configure
3	AI0012(#3)	Inactive	0.00 dB	<input type="checkbox"/>	Configure
4	AI0013(#4)	Inactive	0.00 dB	<input type="checkbox"/>	Configure

Audio Outputs

	Name	Connection	Pilot Active	Feedback Destroyer	AMP Monitoring	Volume	Delay	Limiter Threshold	DSP	Limiter Status
1	AO00017(#1)	HVAudioBus0005(#1)	<input checked="" type="checkbox"/>	<input type="checkbox"/>	<input checked="" type="checkbox"/>	0.00 dB	0 ms	0.00 dB	Configure	<input type="checkbox"/>
2	AO00018(#2)	HVAudioBus0006(#2)	<input checked="" type="checkbox"/>	<input type="checkbox"/>	<input checked="" type="checkbox"/>	0.00 dB	0 ms	0.00 dB	Configure	<input type="checkbox"/>
3	AO00019(#3)	HVAudioBus0007(#3)	<input checked="" type="checkbox"/>	<input type="checkbox"/>	<input checked="" type="checkbox"/>	0.00 dB	0 ms	0.00 dB	Configure	<input type="checkbox"/>
4	AO00020(#4)	HVAudioBus0008(#4)	<input checked="" type="checkbox"/>	<input type="checkbox"/>	<input checked="" type="checkbox"/>	0.00 dB	0 ms	0.00 dB	Configure	<input type="checkbox"/>
5	AO00021(#5)	HVAudioInput0003(#1)	<input checked="" type="checkbox"/>	<input type="checkbox"/>	<input checked="" type="checkbox"/>	0.00 dB	0 ms	0.00 dB	Configure	<input type="checkbox"/>
6	AO00022(#6)	HVAudioInput0004(#2)	<input checked="" type="checkbox"/>	<input type="checkbox"/>	<input checked="" type="checkbox"/>	0.00 dB	0 ms	0.00 dB	Configure	<input type="checkbox"/>
7	AO00023(#7)	HVAudioInput0005(#3)	<input checked="" type="checkbox"/>	<input type="checkbox"/>	<input checked="" type="checkbox"/>	0.00 dB	0 ms	0.00 dB	Configure	<input type="checkbox"/>
8	AO00024(#8)	Line Output	<input type="checkbox"/>	<input type="checkbox"/>	<input type="checkbox"/>	0.00 dB	0 ms	0.00 dB	Configure	<input type="checkbox"/>

1 Audio Inputs

The **Audio Inputs** field contains all available audio inputs locally accessible in the SMART-CU-11LT/LCD control unit. Item 1 on the above figure is a line level input available via a Phoenix connector on the side wall of the ABT-ISLE module. A built-in Audio-4/12 card in the SMART-CU-11LT/LCD units had 4 independent audio inputs available on Phoenix sockets of the ABT-ISLE module.

2 Audio Inputs / Type

In order to activate the input, change the value **Inactive** into **Line IN**. Double-clicking the name of the audio input enables to change the generic name assigned by the configurator.

3 Audio Outputs / Name

Audio-4/12 card has 12 independent audio outputs. Double-clicking the name of the audio output enables to change the generic name assigned by the configurator.

4 Audio Outputs / Connection

This is a very important item on the configurator. Here we define whether the control unit uses only the connections on 4 common, internal 100 V buses or amplifiers are connected directly to individual inputs on the **HVAudioInput** control cards, or we use a mixed mode (some cards are supplied by internal 100 V buses, some from individual inputs). Defining the **Connection** field is a necessary condition for proper operation of the smartVES system. One should remember that the denotation **HVAudioInput...** (#1,2,3 etc.) means the physical location of the card on the slot. The number following # refers to the number of a slot.

The line output is not monitored by the system. The unit treats the output lines as a zone in the system (eg. signal to an independent PA system) to which can transmit the message.

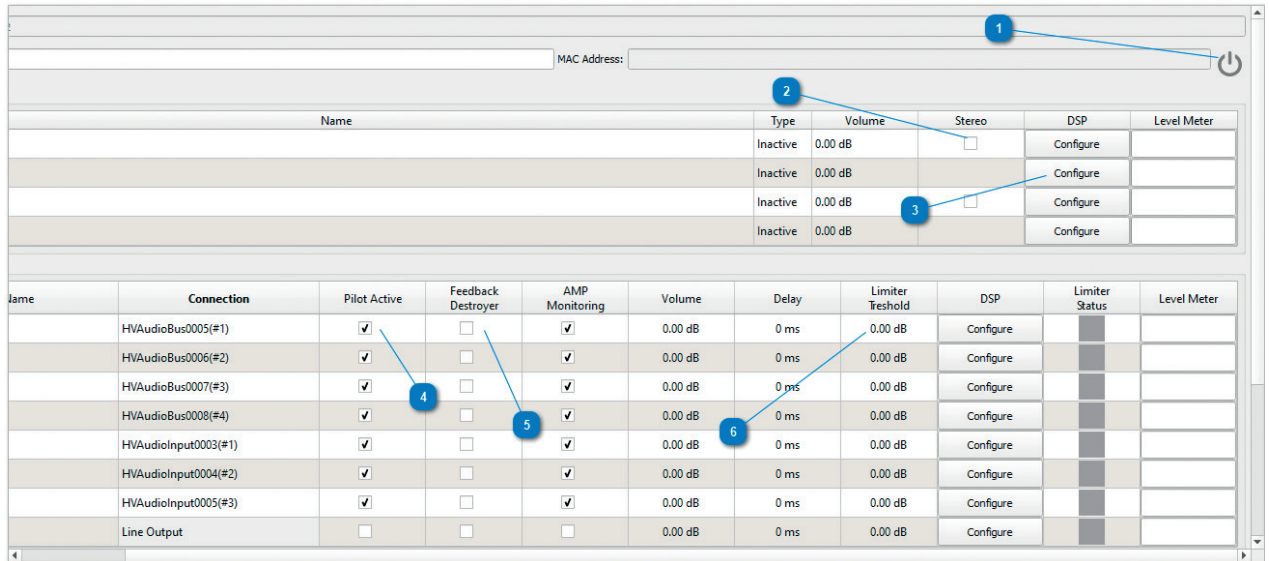



Name	Type	Volume	Stereo	DSP	Level Meter
	Inactive	0.00 dB	<input type="checkbox"/>	Configure	
	Inactive	0.00 dB	<input type="checkbox"/>	Configure	
	Inactive	0.00 dB	<input type="checkbox"/>	Configure	
	Inactive	0.00 dB	<input type="checkbox"/>	Configure	

Name	Connection	Pilot Active	Feedback Destroyer	AMP Monitoring	Volume	Delay	Limiter Threshold	DSP	Limiter Status	Level Meter
	HVAudioBus0005(#1)	<input checked="" type="checkbox"/>	<input type="checkbox"/>	<input checked="" type="checkbox"/>	0.00 dB	0 ms	0.00 dB	Configure		
	HVAudioBus0006(#2)	<input checked="" type="checkbox"/>	<input type="checkbox"/>	<input checked="" type="checkbox"/>	0.00 dB	0 ms	0.00 dB	Configure		
	HVAudioBus0007(#3)	<input checked="" type="checkbox"/>	<input type="checkbox"/>	<input checked="" type="checkbox"/>	0.00 dB	0 ms	0.00 dB	Configure		
	HVAudioBus0008(#4)	<input checked="" type="checkbox"/>	<input type="checkbox"/>	<input checked="" type="checkbox"/>	0.00 dB	0 ms	0.00 dB	Configure		
	HVAudioInput0003(#1)	<input checked="" type="checkbox"/>	<input type="checkbox"/>	<input checked="" type="checkbox"/>	0.00 dB	0 ms	0.00 dB	Configure		
	HVAudioInput0004(#2)	<input checked="" type="checkbox"/>	<input type="checkbox"/>	<input checked="" type="checkbox"/>	0.00 dB	0 ms	0.00 dB	Configure		
	HVAudioInput0005(#3)	<input checked="" type="checkbox"/>	<input type="checkbox"/>	<input checked="" type="checkbox"/>	0.00 dB	0 ms	0.00 dB	Configure		
	Line Output	<input type="checkbox"/>	<input type="checkbox"/>	<input type="checkbox"/>	0.00 dB	0 ms	0.00 dB	Configure		

Audio-4/12 editing window – continued

1 On-line mode

Online mode allows to preview the levels of inputs and outputs audio channels. In addition, allows to change parameters such as delay, volume level, limiter threshold and EQ settings. After uploading the configuration into the system you can enter the on-line mode by clicking the  icon, it will then change it's color to green indicating active on-line mode. Any parameter changes on the card must be preceded by selecting on-line mode . Switching Feedback Destroyer (Feedback Suppressor) requires re-upload the configuration to the system.

2 Audio Inputs / Stereo

Selecting [Stereo](#) option causes summing two audio signals into one in the ratio of 50 / 50 which results in correct stereo signal transmission to the loudspeaker zones.

3 Audio Inputs / DSP

Audio card on each audio input has a 3 band parametric equalizer which can be freely configurable in two ways:

1. by uploading the configuration to the system with the center frequency, filter quality and gain settings;
2. by changing the parameters of the filters in on-line mode.

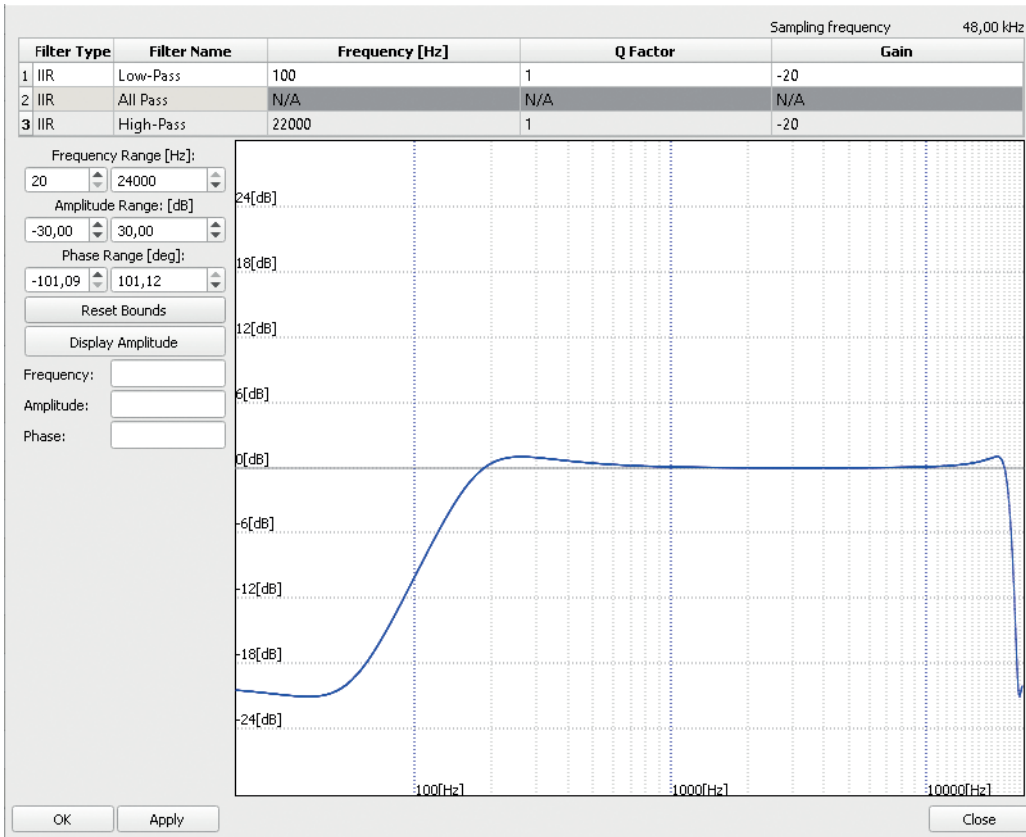

4 Audio Outputs / Active Pilot

Selected [Active Pilot](#) option activates the control of the connection between audio output (DSP) and amplifier 100 V.

5 Audio Outputs / Feedback Destroyer

Activating [Feedback Destroyer](#) means that in places where the speakers are located in close proximity to the system microphone, effect of acoustic feedback is significantly limited.

6 Audio Outputs – other options

The window allows to change parameters like delay, volume level, limiter threshold and EQ. Setting parameters is possible in two ways:

1. by changing the values in a particular window [Volume / Delay](#) and uploading the configuration to the system;
2. by changing the parameters in the [Volume / Delay](#) section in on-line mode.

Audio card on each output has 8 band parametric equalizer which can be freely configurable in two ways:

1. by changing the center frequency, filter quality and gain and uploading the configuration to the system;
2. by changing the parameters of the filters in on-line mode.

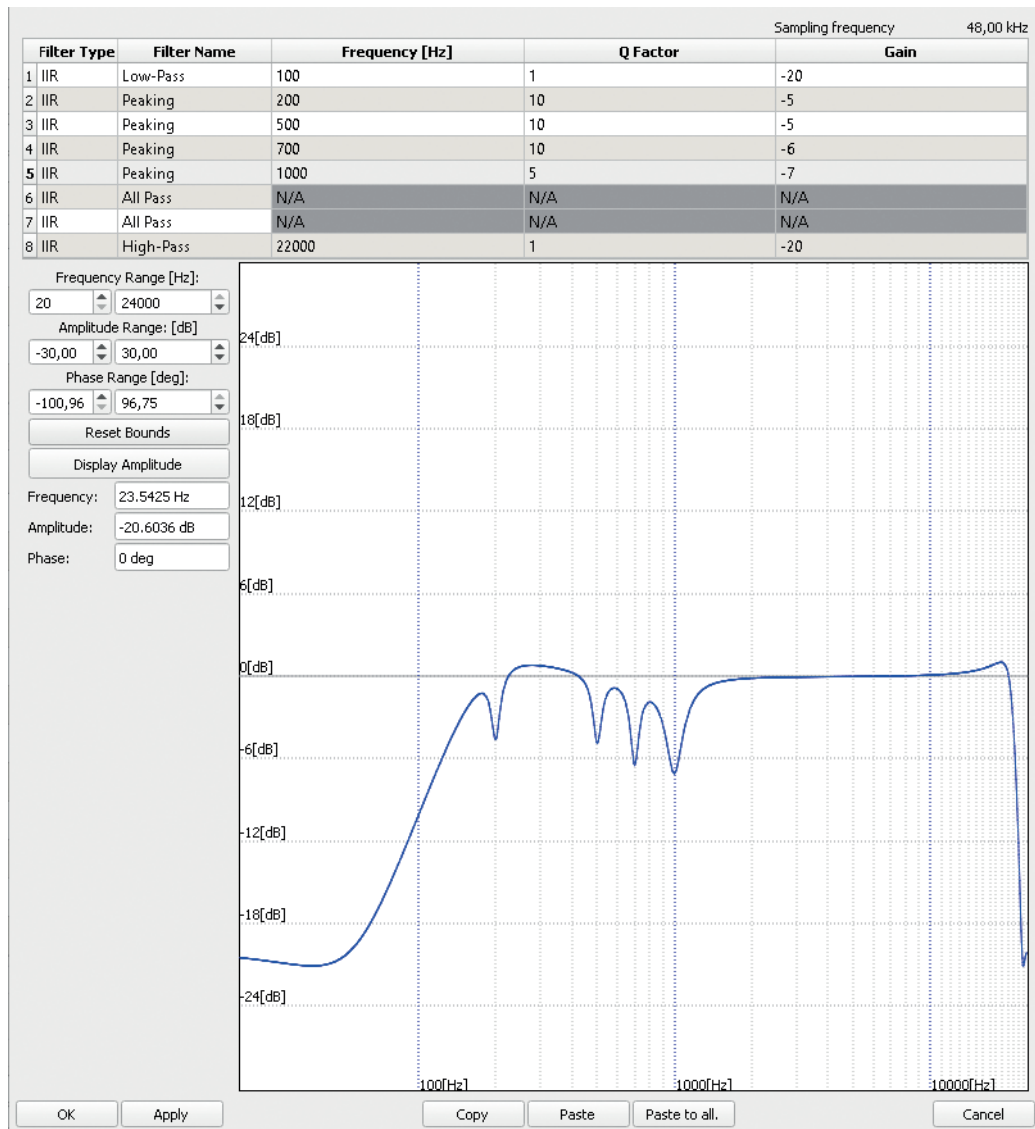

[Paste to all](#) function allows to copy EQ settings to all outputs available in the control unit. To do so select [Copy](#) to save the settings of the filters and then select [Paste to all](#) to propagate all filters settings to all outputs.

Setting the level of threshold below 0 dB activates the audio limiter. Signal level exceeding threshold is indicated by the red color in the [Limiter](#) status. Green indicates that the output is below the threshold. In practice activation of audio limiter means that above a threshold, output signal is not increasing, regardless of what value the input signal reaches. [Limiter](#) allows to protect the system amplifiers from clipping the signal peaks and sharp reduction in high-level transients without affecting the essential content sound material.

[Signal Level Meter](#) is only active in on-line mode. The maximum level shown on the indicator corresponds to the voltage of 1 V RMS output codec.

13.3.16 xNET-1Gb/WAN/RS

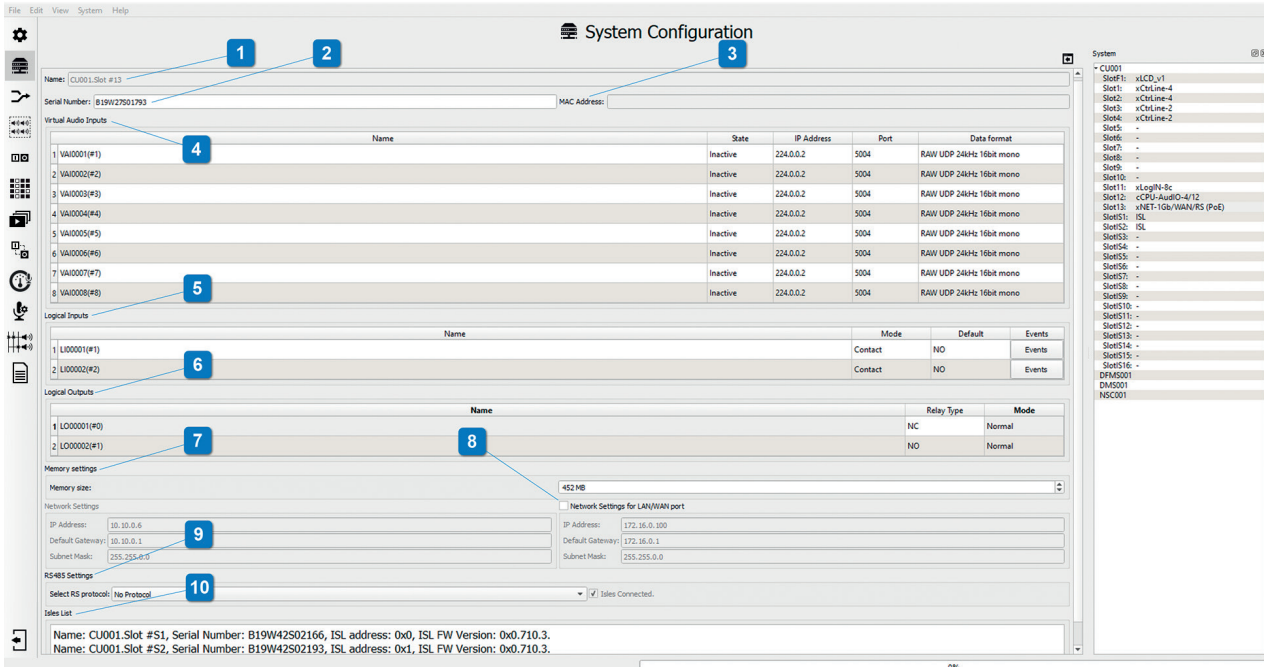

The screenshot shows the 'System Configuration' window for an xNET card. The interface includes the following sections and fields:

- Name:** CU001.Slot #13
- Serial Number:** B19W27501793
- MAC Address:** (empty field)
- Virtual Audio Inputs:** A table with 8 rows, each representing an audio input (e.g., VIA0001(#1) to VIA0008(#8)).
- Logical Inputs:** A table with 2 rows (LO0001(#1) and LO0002(#2)).
- Logical Outputs:** A table with 2 rows (LO0001(#0) and LO0002(#1)).
- Memory settings:** Memory size: 452 MB
- Network Settings for LAN/WAN port:** IP Address: 172.16.0.100, Default Gateway: 172.16.0.1, Subnet Mask: 255.255.0.0
- RS-485 Settings:** Select RS protocol: No Protocol

1 Name

Field in which xNET card name is generic assigned.

The name consists of two parts:

- › control unit name (editable in the BUS card)
- › slot number in which it is located

2 Serial Number

Field with serial number of xNET card.

3 MAC Address

Field with MAC address of xNET card.

4 Virtual Audio Inputs

A window enabling system configuration to receive audio stream from the network.

The xNET card enables reception of 8 audio streams as independent sources.

5 Logic Inputs

Logical Inputs field allows you to configure the available logical inputs in xNET card.

6 Logic Outputs

Logical Outputs field allows you to configure the available logical outputs in xNET card.

7 Memory settings

Field informing about capacity of installed memory card in module.

This value is automatically filled after reading system topology.

8 Network Settings for LAN/WAN port

Edit field of LAN / WAN port network parameters.

In a default configuration, a device with xNET card works as DHCP server and automatically assigns a network address to connected device (e.g. computer) to LAN / WAN port.

After defining the parameters, it is possible to set a fixed network address of the xNET card.

It should be remembered that a device with xNET card in which permanent addressing is set will not be visible to devices whose network card is in automatic address acquisition (DHCP) mode.

9 RS485 Settings

Functionality of this field is temporarily inactive and will be available in the future.

10 Isles List

Window displays information about connected ABT-ISLE modules after reading system topology.

System configuration for receiving multicast from network

To enable system to receive audio stream, open the settings of the xNET-1Gb/WAN/RS network card that will be connected to network.

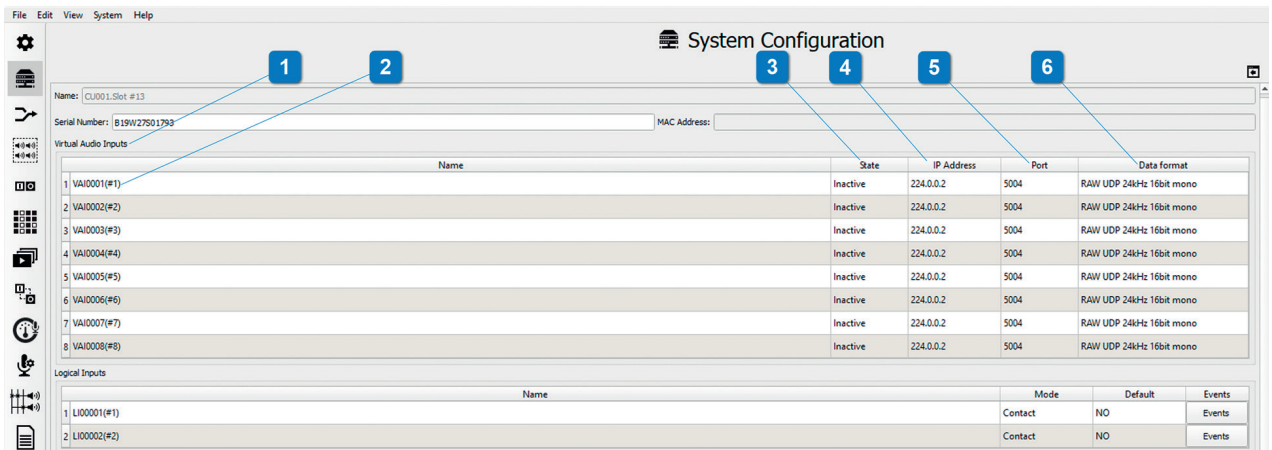

The screenshot shows the 'System Configuration' window. The 'Virtual Audio Inputs' table is highlighted with numbered callouts:

	Name	State	IP Address	Port	Data format
1	VAI0001(#1)	Inactive	224.0.0.2	5004	RAW UDP 24kHz 16bit mono
2	VAI0002(#2)	Inactive	224.0.0.2	5004	RAW UDP 24kHz 16bit mono
3	VAI0003(#3)	Inactive	224.0.0.2	5004	RAW UDP 24kHz 16bit mono
4	VAI0004(#4)	Inactive	224.0.0.2	5004	RAW UDP 24kHz 16bit mono
5	VAI0005(#5)	Inactive	224.0.0.2	5004	RAW UDP 24kHz 16bit mono
6	VAI0006(#6)	Inactive	224.0.0.2	5004	RAW UDP 24kHz 16bit mono
7	VAI0007(#7)	Inactive	224.0.0.2	5004	RAW UDP 24kHz 16bit mono
8	VAI0008(#8)	Inactive	224.0.0.2	5004	RAW UDP 24kHz 16bit mono

The 'Logical Inputs' table is also visible below:

	Name	Mode	Default	Events
1	LI00001(#1)	Contact	NO	Events
2	LI00002(#2)	Contact	NO	Events

1 Virtual Audio Inputs

Window for editing parameters of virtual audio inputs.

2 Name

Window for editing name of virtual audio inputs.

3 State

From the drop-down list, select **Line input** to make it active.

4 Adres IP

Window for editing of IP address for receiving audio stream.

5 Port

Field for editing of port for receiving audio stream.

6 Data format

From the drop-down list select format in which the stream is transmitted.

In our example it will be **RTP 48kHz 16bit mono**

Multicast network audio streaming

VLC multicasts settings step by step.

1. In **File** menu select [Stream](#)

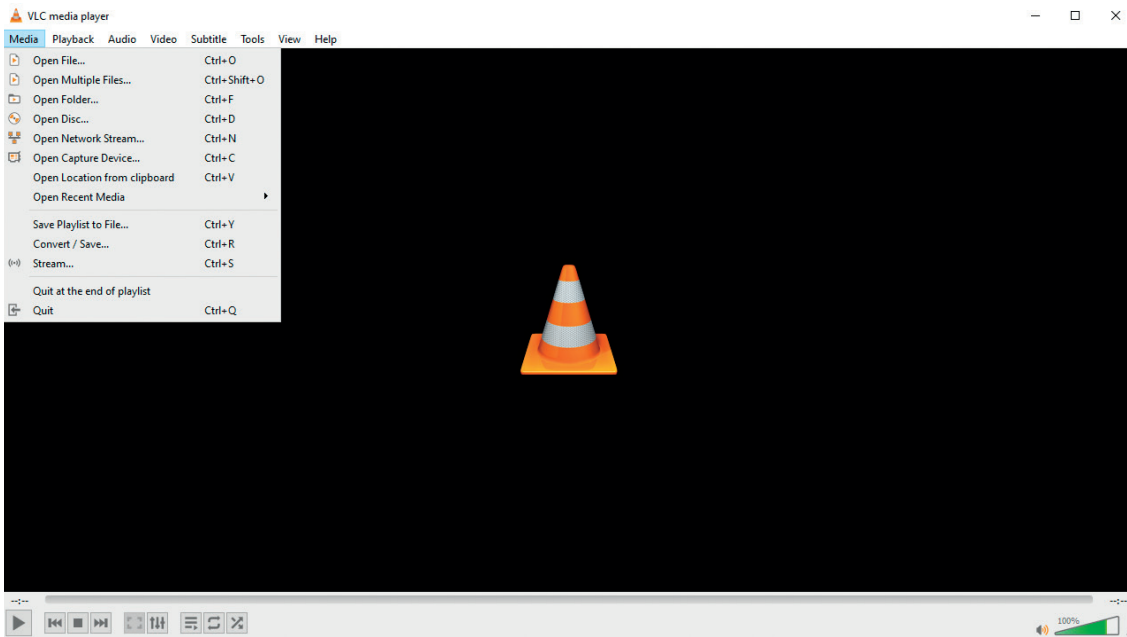

2. Add audio file for streaming

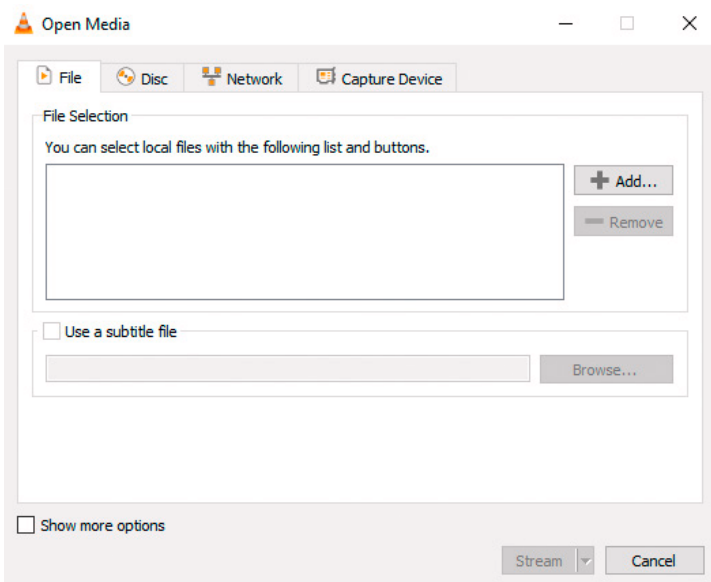

3. In File menu select [Stream](#)

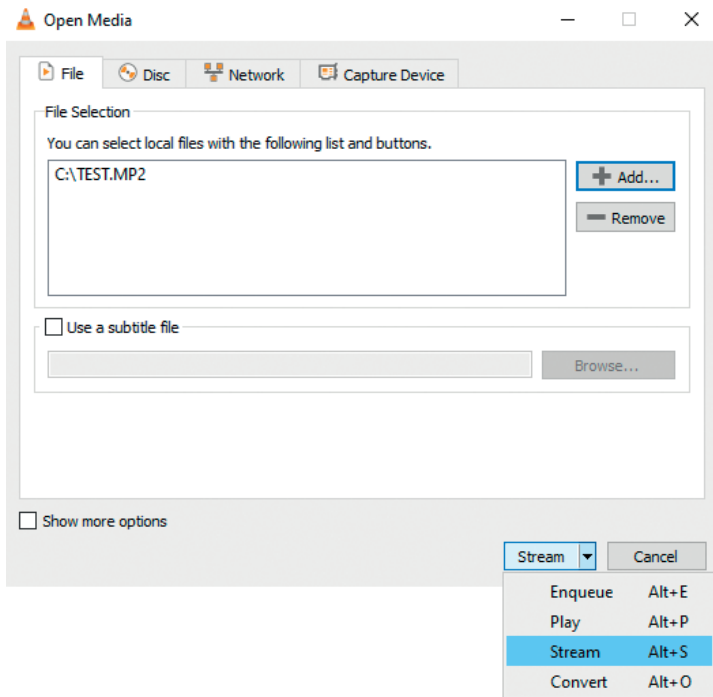

4. Select [Next](#)

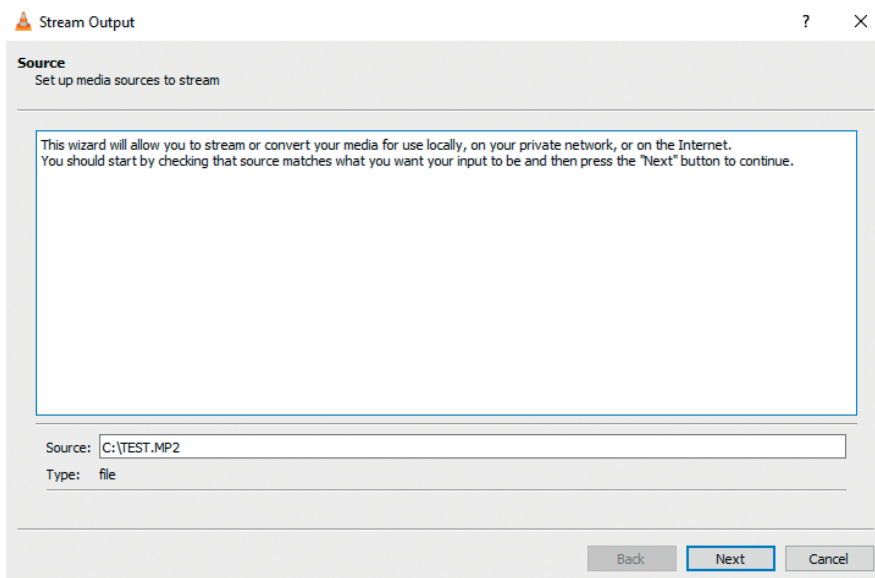

5. Add output stream as below

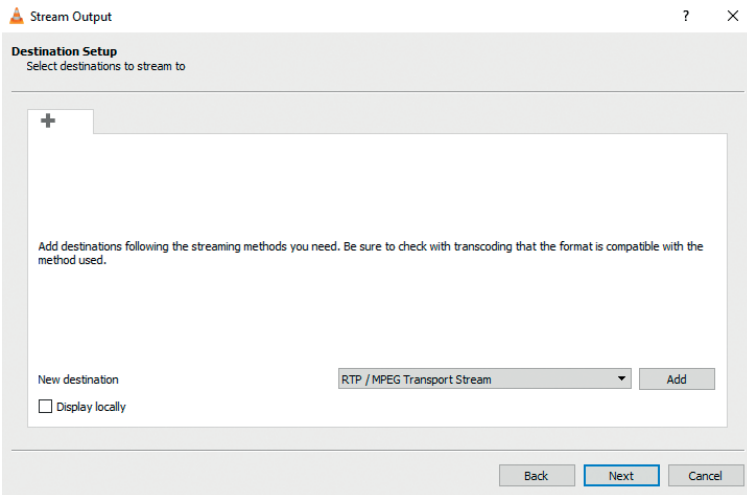

The screenshot shows the 'Stream Output' dialog box with the 'Destination Setup' tab selected. The title bar reads 'Stream Output' with a help icon and a close icon. Below the title bar, the text 'Destination Setup' is followed by the instruction 'Select destinations to stream to'. A large empty rectangular area is intended for listing destinations. Below this area, there is a 'New destination' section with a dropdown menu set to 'RTP / MPEG Transport Stream' and an 'Add' button. A checkbox labeled 'Display locally' is also present. At the bottom of the dialog are 'Back', 'Next', and 'Cancel' buttons.

6. Click **Add** button and configure stream ip address and port

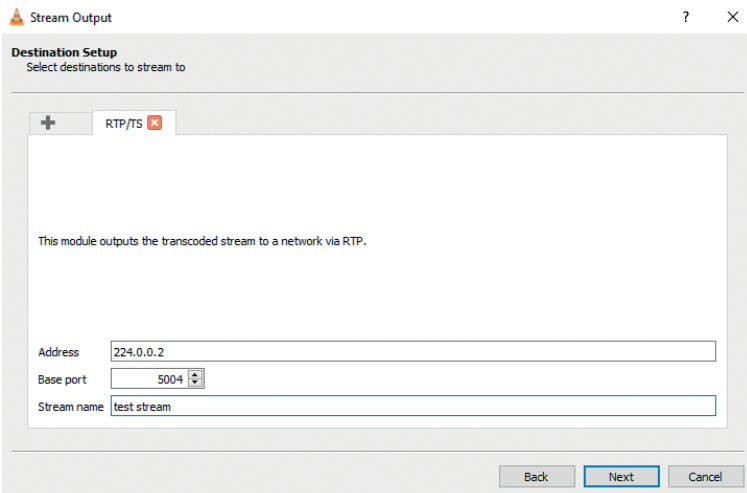

The screenshot shows the 'Stream Output' dialog box with the 'Destination Setup' tab. A tab labeled 'RTP/TS' is now active. The text 'This module outputs the transcoded stream to a network via RTP.' is displayed. Below this, there are three input fields: 'Address' with the value '224.0.0.2', 'Base port' with a spinner set to '5004', and 'Stream name' with the value 'test stream'. The 'Back', 'Next', and 'Cancel' buttons are at the bottom.

7. Click **Edit selected profile** button

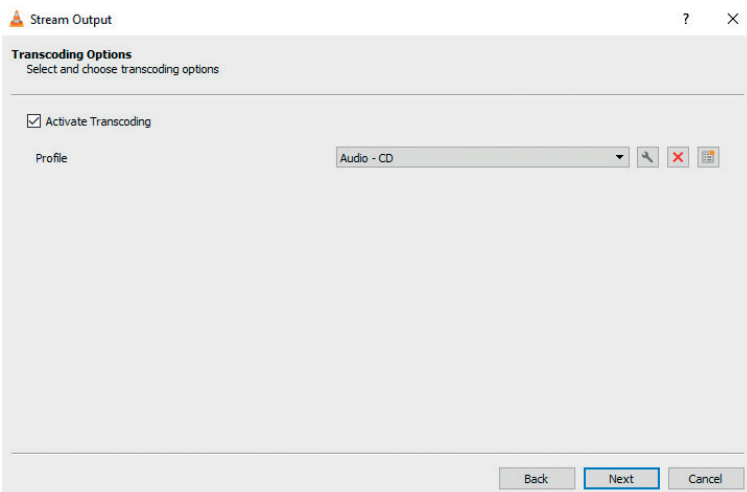

The screenshot shows the 'Stream Output' dialog box with the 'Transcoding Options' tab selected. The title bar reads 'Stream Output' with a help icon and a close icon. Below the title bar, the text 'Transcoding Options' is followed by the instruction 'Select and choose transcoding options'. A checkbox labeled 'Activate Transcoding' is checked. Below it, there is a 'Profile' section with a dropdown menu set to 'Audio - CD' and an 'Edit selected profile' button (represented by a magnifying glass icon). At the bottom of the dialog are 'Back', 'Next', and 'Cancel' buttons.

8. Select **Audio codec** tab and set parameters as below and accept by **Save** button.

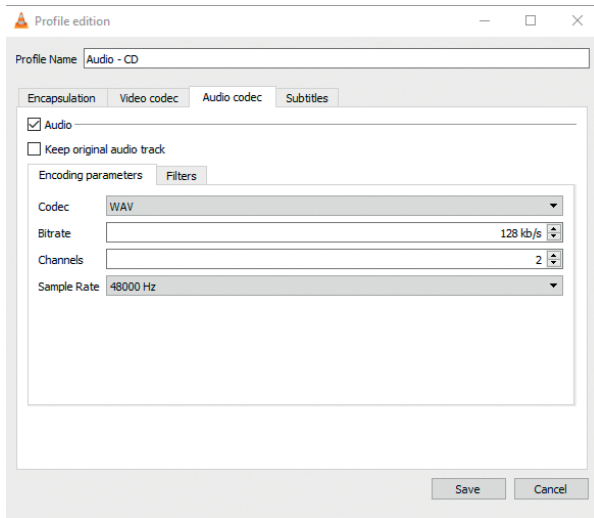

9. Click **Next** button.

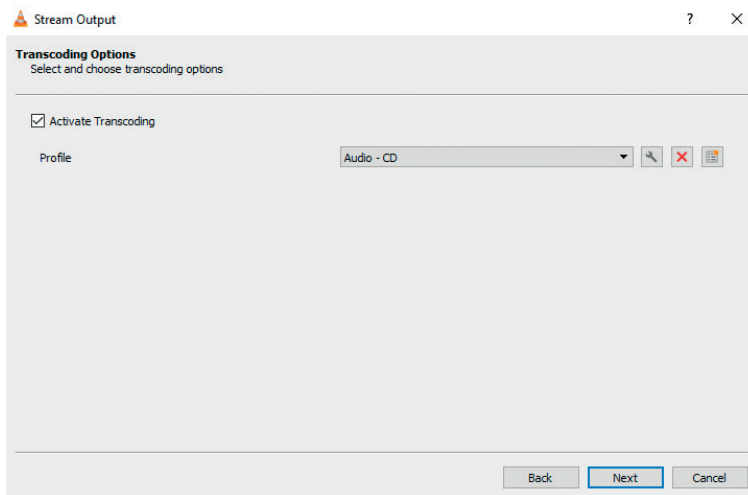

10. Push **Stream** button to activate audio stream.

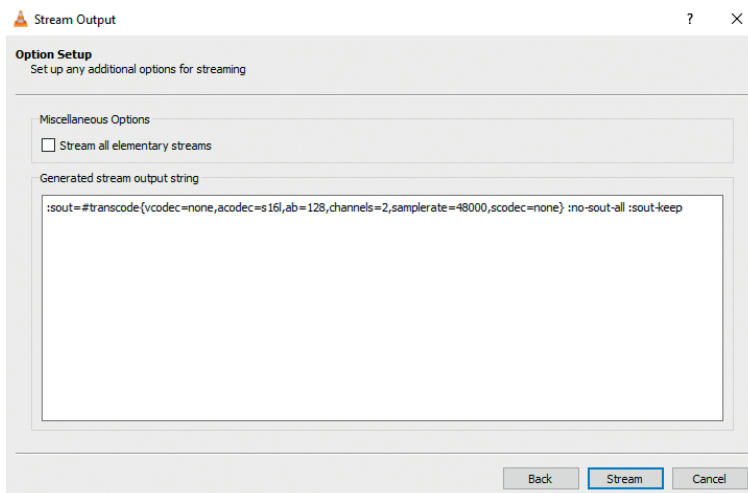

13.4 Description of backup functionality for smartVES system

The **Backup** function is an advanced method of replacement of a damaged amplifier in order to provide for continuity of message propagation in accordance with the EN54-16 standard for sound emergency systems. For a functionality analysis, three various methods should be considered of amplifier connection in the smartVES system:

1. Amplifiers / amplifier channels (max 4) connected to four 100 V buses common for all control cards.
2. Amplifiers / amplifier channels connected to control card individual inputs. Each control card may be supplied by only one channel of the amplifier.
3. Mixed mode: out of the 11 available slots in the CU-11 control unit, some control cards may be supplied by 100 V buses, and some from individual inputs on the control cards.

Method 1 – only 100 V buses

In case there are up to 4 amplifiers connected to a control unit and we use 4 100 V buses. The system, having detected a failure of one of the amplifiers, will replace it with an amplifier connected to another bus, as available, then the message priority criterion, and in case of priority equivalence – taking the programmed modes **FIFO**, **LIFO**. For **FIFO** – the amplifier which supplies Message 1 will not be expropriated to 2 until completion of Message 1 (matrix). For **LIFO** – the Message 1 amplifier will be disconnected and assigned as backup to Message 2.

Expropriation of amplifiers in case of a failure on one of the buses, as detected, is done by means of an analysis of the Matrices – or, more precisely, their priorities – executed at the moment of failure occurrence. The amplifier is always expropriated which executes Matrices of the lowest priority and a lower one than the matrix for which the amplifier is in disrepair. Such logics always provides an amplifier for Matrices of the highest priority, even with repeated damages to backup amplifiers.

It should be noted, though, that the buses are being assigned on a dynamic basis and according to the needs of the zones to be matrixed. This means that the backup system does not switch amplifiers at the moment a fault has been detected, but on being used, i.e. matrixing. An amplifier failure is signalled on detection of the fault. According to the EN54-16 standard, detection takes maximum 100 seconds following failure, and the time to switch over to a backup amplifier, from the moment the fault has been detected, is 10 seconds (in smartVES it takes max 1 second). After dematrixing, the amplifier which has been used returns to the resource group to be assigned again if needed – this is dynamic selection of an amplifier as needed.

Mode 2 – amplifiers connected to control card individual inputs

In this mode, a damaged amplifier connected to a control card individual input, will be replaced by an amplifier supplying one of the four 100 V buses. It must be ticked in the configurator which of the buses is the **Backup individual amp** so that when a fault occurs a specific amplifier from a bus was assigned instead of the damaged one. All the prioritizing principles, as described above, **FIFO**, **LIFO** and dynamic assignment of backup resources (assigning and returning as needed) pertain, as in Mode 1.

Mode 3 – mixed: some control cards may be supplied from 100 V buses, some from individual inputs on control cards

With such connection and system configuration, 100V bus amplifier failures are taken care of by replacing the affected amplifier with free 100 V bus amplifier resources, whereas a failure of an amplifier on a control card individual input triggers dynamic assignment of the 100 V bus amplifier to have been declared in the configurator as the **Backup individual amp** (a specific amplifier). In this mode, the declared individual input backup amplifier will never replace a 100 V bus-supplying amplifier. Therefore, this mode requires that two backup amplifiers be provided: a separate backup amplifier for 100 V buses, which, in principle, is a high-power one, and a separate amplifier for amplifiers connected to control card individual inputs.

13.5 Priority Manager Configuration

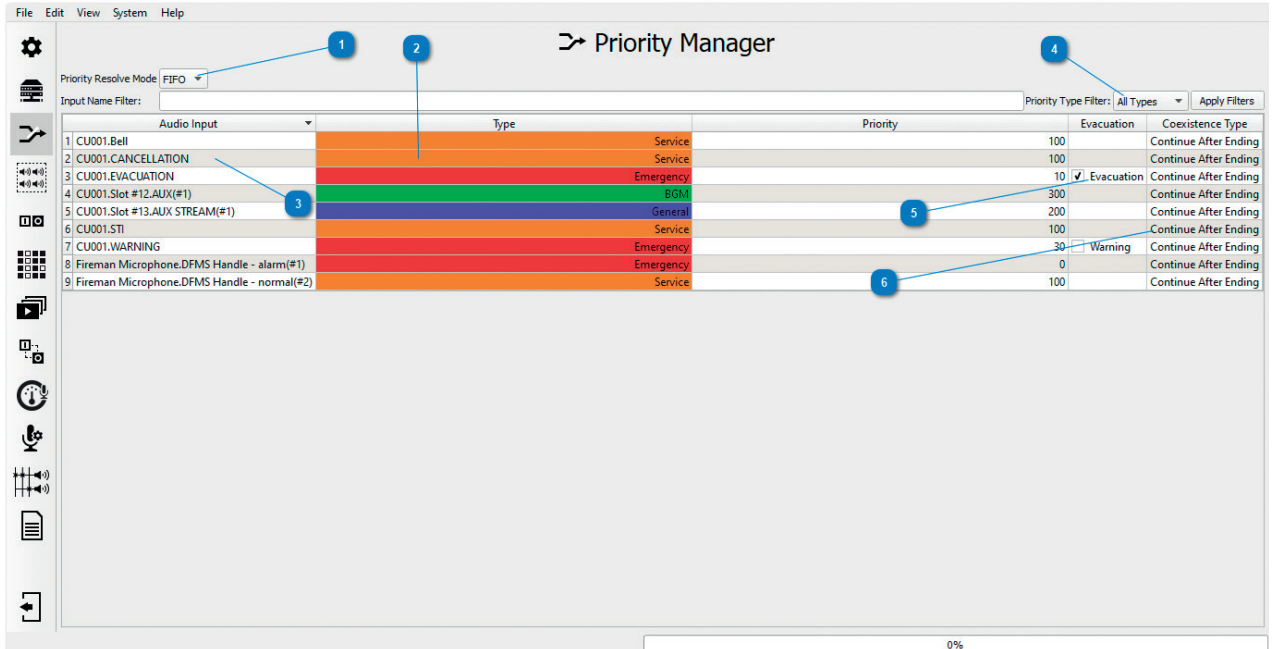

Audio Input	Type	Priority	Evacuation	Coexistence Type
1 CU001.Bell	Service	100		Continue After Ending
2 CU001.CANCELLATION	Service	100		Continue After Ending
3 CU001.EVACUATION	Emergency	10	<input checked="" type="checkbox"/> Evacuation	Continue After Ending
4 CU001.Slot #12.AUX(#1)	BGM	300		Continue After Ending
5 CU001.Slot #13.AUX STREAM(#1)	General	200		Continue After Ending
6 CU001.STI	Service	100		Continue After Ending
7 CU001.WARNING	Emergency	30	<input type="checkbox"/> Warning	Continue After Ending
8 Fireman Microphone.DFMS Handle - alarm(#1)	Emergency	0		Continue After Ending
9 Fireman Microphone.DFMS Handle - normal(#2)	Service	100		Continue After Ending

Each zone microphone, fireman microphone or audio input available in the system must have its priority defined in order to ensure correct operation, as intended for sound emergency systems.

1 Message priority mode in case of conflict – FIFO / LIFO

Priority Resolve Mode – this is a global system function which defines the system's behaviour in case a conflict occurs. The conflict being a simultaneous transmission to the speaker zone from two or more audio sources of the same priority.

For **FIFO** (First in first out) – in the case when Source 1 of Priority X is transmitting to Output Y and after some time Source 2 of Priority X wants to transmit to Output Y too, Source 2 can not transmit until Source 1 has finished transmitting to Output Y.

For **LIFO** (Last in first out) – in the case when Source 1 of Priority X is transmitting on Output Y (speaker zone) and, after some time, Source 2 of Priority X will start transmitting on Output Y (speaker zone) too, then Source 2 will replace Source 1, as transmitting, and will commence transmitting to Output Y.

Priority Resolve Mode also determines the method of dynamic assignment of a backup power amplifier in case a failure occurs of the amplifier modules which are responsible for transmission of simultaneous messages of the same priorities. In case two equally prioritized messages are executed to various zones, Message 1 of Priority (100), Message 2 of Priority (100) too, which was matrixed after Message 1 – when an amplifier module failure occurs for the **FIFO** mode: the amplifier which supplies Message 1 will not be taken over by Message 2 until Message 1 (matrix) has been completed; for **LIFO** – the Message 1 amplifier module will be disconnected and assigned as a backup amplifier for Message 2.

2 Audio source type selection: [Emergency](#), [General](#), [Service](#), [BGM](#)

The smartVES has 4 priority groups, each of the groups has 99 levels. Priorities are numbered in the reverse order: the fireman microphone in [Emergency](#) mode has the highest 0 priority the lowest priority is BGM 399.

Priority types:

[Emergency](#), range 0-99 – audio sources with the assigned priority ranged 0-99 are active only when the system is in the [Alarm Mode](#). The [Emergency](#) priority can only be assigned to the ABT-DFMS fireman microphone, messages recorded on memory cards and control unit audio inputs.

[Service](#), range 100-199 – can be assigned to every audio source type and does not allow matrix activation in the [Alarm Mode](#). A loss of the 230 V AC basic power supply does not deactivate [Service](#)-type source messages. Sources of priorities contained within this group are subject to the [Zone\(s\)off](#) function.

[General](#), range 200-299 – can be assigned to zone microphones and messages. It does not operate in the alarm mode and in case of a loss of the 230 V AC basic power supply. Sources of priorities contained within this group are subject to the [Silence](#), [Power Save](#) and [Zone\(s\)off](#) functions.

[BGM](#), range 300-399 – assigned only to audio inputs located in control units and zone microphones. BGM-priority audio source Matrices do not operate in the alarm mode and in case of a loss of the 230 V AC basic power supply. Sources of priorities contained within this group are subject to the [Silence](#), [Power Save](#) and [Zone\(s\)off](#) functions.

As standard, the configuration software assigns arbitrarily priorities from the [Emergency](#) group, depending on the audio source, that is:

1. For the ABT-DFMS fireman microphones – the [Emergency](#) Priority NB 0-10 is the highest priority pool reserved only for these devices.
2. Sound messages played back from system memory cards for the [Emergency](#) Priority [Evacuation](#) checkbox – these are assigned a value ≥ 10 .
3. Sound messages played back from system memory cards for the [Emergency](#) Priority [Warning](#) checkbox – these are assigned a value ≥ 30 .
4. For the remaining audio inputs on control units with a possibility of being assigned the [Emergency](#) Priority [Evacuation](#) checkbox – these are assigned a value ≥ 20 , and for the [Warning](#) option ≥ 40 .

3 Audio source description

The [Audio Input](#) and [Component](#) items indicate specifically which audio input, zone microphone, fireman microphone or message a selected priority is assigned. The [Component](#) tab informs of the location in which a given message was recorded and will be played back from or – in case of audio inputs – specifies the device in which the selected input is located.

4 Zone retained signaling mode, [Evacuation](#) / [Warning](#) modes

Having assigned the [Emergency](#) mode to any audio source, the [Warning](#) checkbox appears in the right corner. This means that as the initial setting for the [Evacuation](#) mode, in case of transmitting a message on a given zone, on the RGB button diode programmed as the [Select Zone](#) of this zone, the red LED will be blinking. Ticking the checkbox is equivalent to changing the mode to [Evacuation](#) which results in the RGB LED – the red one – being on during a message transmission.

5 Priority group filtering

The filtering tool enables to display all audio sources from a selected priority group. To do this, click the left mouse button once on the [All Types](#) tab. This will result in options dropped down, then select a group and confirm activation of the filter by clicking [Apply Filters](#).

6 Coexistence type



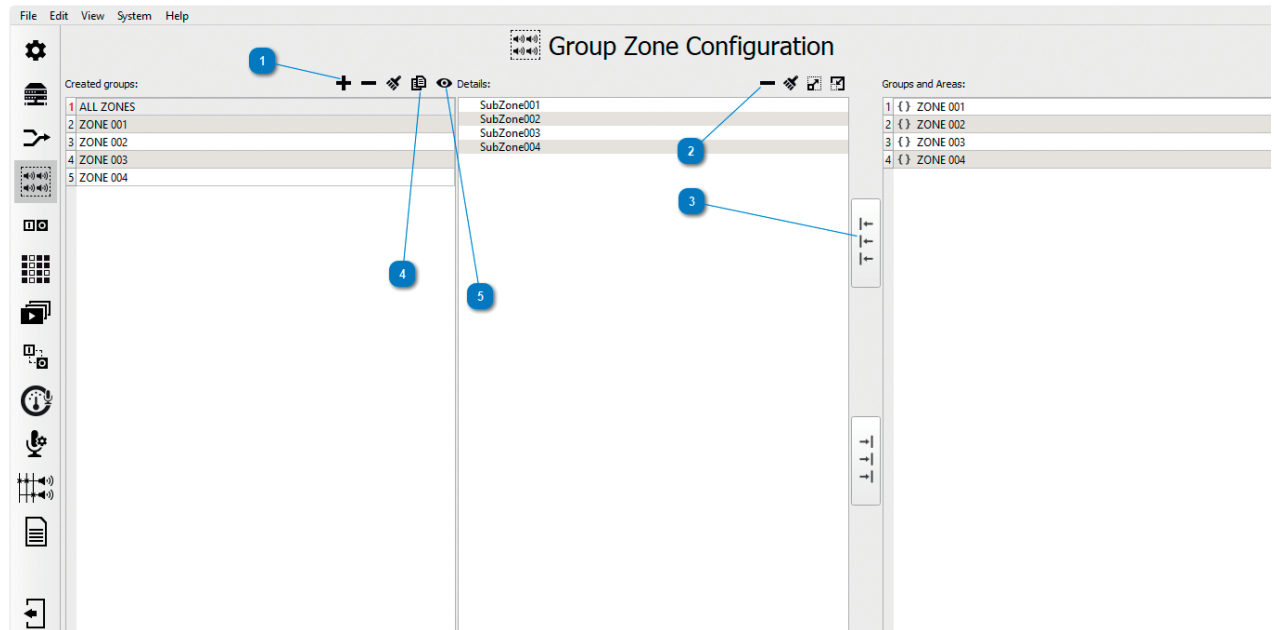

This function defines the systems behaviour when an incoming message has superseded the message occupying this zone at the moment. If the superseding message / audio source is defined as [Continue After Ending](#) it means that the system will return to transmitting the previous (lower priority) message after a higher priority message has ended. If the superseding message / audio source is defined as [Remove All After Ending](#) then after the end of the higher priority (superseding) message, the lower priority message will not be restored.

13.6 Group Zone Configuration



This function is available only from the advanced configurator level – [Basic Configuration](#) – [Configuration Mode](#) – [Advanced](#). It is used to combine any predefined speaker lines / zones into one. A group created in this way has the same functionalities in the system as a single zone.

In order to create a new group, the following must be done:

- 1 **Using the + icon**, a new group is created whose generic name is ZoneGroup0000x; the name is editable by moving the mouse cursor over it and pressing the left mouse button.
- 2 From the **Group and Areas** tab, the column on the right hand side of the screen, move the mouse cursor over available **Subzones**, **Zones** and add elements to the group by double-clicking of the left mouse button.
- 3 It is also possible to add all available subzones and zones by means of the dedicated icon .
- 4 **Group cloning function: Clone Group** – this is available under the icon . Highlight the previously created group by moving the mouse cursor over its name and by clicking the left mouse button once. Then select the icon . **Clone group** results in creating a new group of the identical composition as the source group.
- 5 **Group element graphic view: Preview Group** – this is available from the icon . This function presents, in a graphic form, in one table, all groups which have been created, as well as their members.

	SubZone001	SubZone002	SubZone003	SubZone004
ALL ZONES	●	●	●	●
ZONE 001	●			
ZONE 002		●		
ZONE 003			●	
ZONE 004				●

13.7 Control I/O Configuration

This tab is only available from the advanced configurator level – [Basic Configuration](#) – [Configuration Mode](#) – [Advanced](#). The tab consists of 3 pages: [Group Logical Inputs](#), [Group Logical Outputs](#) and [Timers](#).

13.7.1 Group Logical Inputs

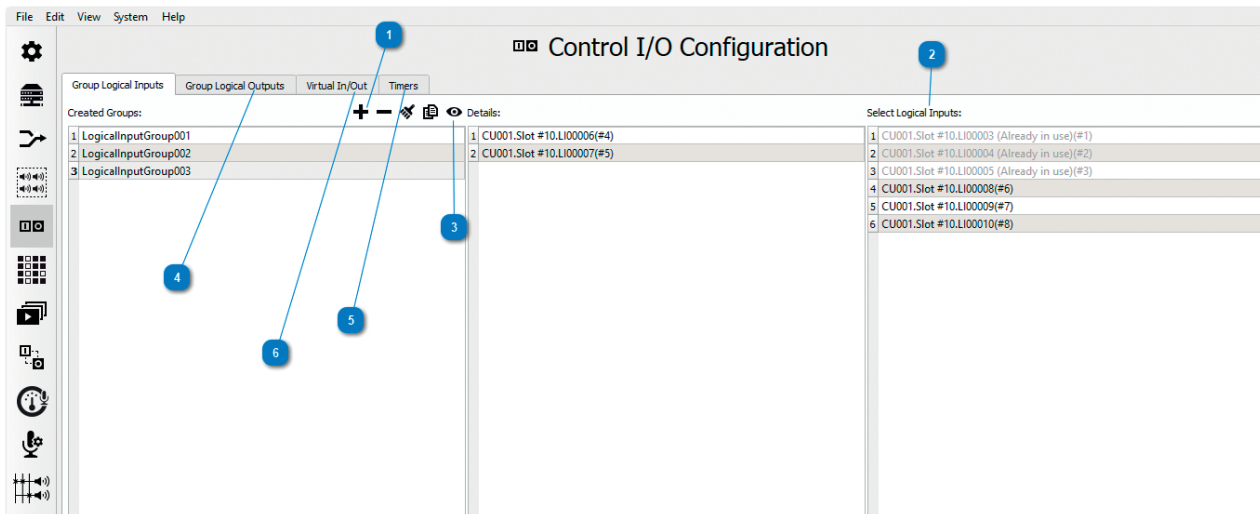

Group Logical Inputs – this is grouping two or more logical inputs in order to trigger action in the system for a specified condition. **In order to create a group:**

- 1 Using the **+** icon, create a new group with the generic name LogicalInputGroup0000x; the name is editable by moving the mouse cursor over it and pressing the left mouse button.
- 2 From the **Select Logical Input** tab, using the left mouse button, add elements to the group. Each of the elements can only be assigned to one group.

The created group is shown in the [Event Configuration](#) tab, in the [Input](#) tab. For a logical input group, execution of the action, as assigned to the group, is determined by fulfilling the [Condition](#) from the [Event Configuration](#) tab. [Condition](#) value =1, =0, = decimal value, < decimal value, > decimal value, <= decimal value, >= decimal value. The decimal value entered is to be interpreted in the following way – each group member has an item assigned: the first added element in the middle table from the [Control I/O Configuration](#) tab – [Group Logical Inputs](#) comprises the bit of the smallest weight, found in the digital word, rightmost. The last element from the group is the bit of the biggest weight, leftmost. A binary number created in this way must be translated into the decimal system and entered into the condition.

For **NO** (Normally Open) **Default Logical Inputs** – 1 is input closing, 0 – opening. **NC** (Normally Closed) **Default Logical Input** – 1 is input opening, 0 – closing. If we want to programme a logical input group, e.g. Input 1 NO, Input 2 NO, to trigger any function following closing of both inputs, enter the condition =3 (11 in the binary numeral system).

In case of a 2-input group, we have the following condition options:

- 00 = 0 Opening of both inputs,
- 01 = 1 Closing of Input 1 and opening of Input 2,
- 10 = 2 Opening of Input 1 and closing of Input 2,
- 11 = 3 Closing of both inputs;

If we have a group of 3 logical inputs, Input 1 – NO, Input 2 – NO, Input 3 – NO, we have the following condition options:
 100 = 4 In 1 open, In 2 open, In 3 closed
 101 = 5 In 1 closed, In 2 open, In 3 closed
 110 = 6 In 1 open, In 2 closed, In 3 closed
 111 = 7 In 1 closed, In 2 closed, In 3 closed

- 3 Group element graphic view: Preview Groups** – this is available under the icon . This function presents, in the form of a graphic matrix, in one table, all groups which have been created, as well as their members.

	ALARM CANCELLATION	ALL ZONES	CANCEL ALARM	CLEAR ZONES	D1001	D1006	D1007	D1008	D1009	D1010	D1011	DOWN	EVACUATION	FAULT ACCEPT	FAULT CANCEL	LI00001	LI00002	LI00003	LI00004	LI00005	LI00006	LI00007	LI00008	LI00009	LI00010	LI001	LI002	LOUDER	MUSIC OFF	MUSIC ON	ST1 NOISE	TEST LED
LogicalInputGroup001																●	●															
LogicalInputGroup002																		●	●													
LogicalInputGroup003																				●	●											

- 4 Group Logical Outputs** – this is grouping of two or more logical (relay) outputs in order to simplify assignment of many relay inputs to a given event in the system.

5 Timers

The Timers functions serves to create elements triggering given actions in the smartVES system, using time dependences.

6 Virtual In/Out

It is used to create logical (virtual) inputs, by means of which we can run defined functionalities in the system or activate virtual output. Virtual logic input is activated by means of an SMS protocol, used for communication with monitoring and system management platforms.

13.7.2 Group Logical Outputs

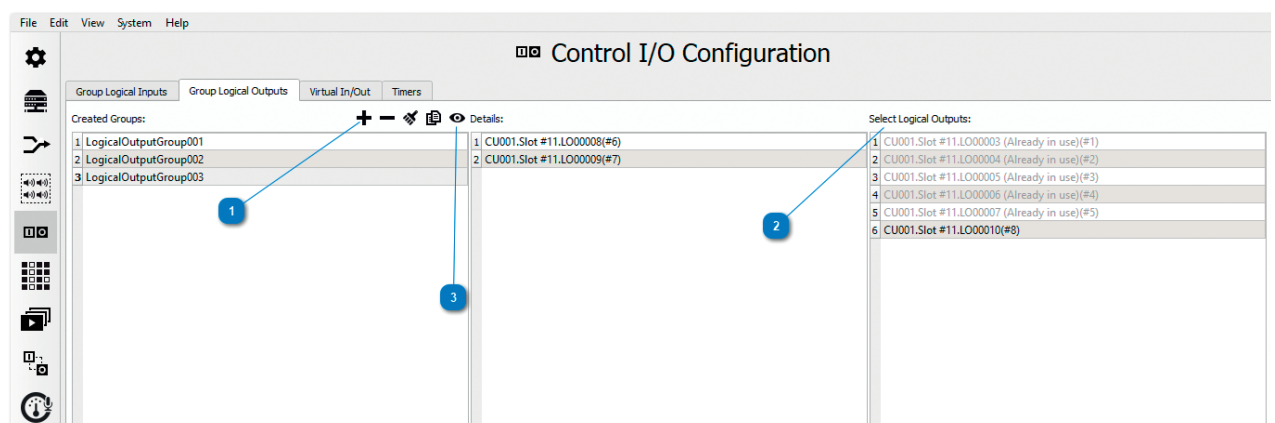

Group Logical Outputs – this is grouping of two or more logical (relay) outputs in order to simplify assignment of many relay inputs to a given event in the system:

- 1 Using the + icon**, create a new group with the generic name LogicalOutputGroup0000x; the name is editable by moving the mouse cursor over it and pressing the left mouse button.
- 2 From the Select Logical Outputs tab**, using the left mouse button, add elements to the group. Each of the elements can only be assigned to one group.

The created group is shown in the [Scenario Configuration – Add control outputs action](#) tab, as well as in [Event Configuration](#), having selected any [Input](#), and then assigning the [General – Components Groups](#) function to it. For a logical output group, execution of a relay output group is determined by the [State](#) parameter which is a decimal number. The decimal value entered is to be interpreted in the following way – each group member has an item assigned: the first added element in the middle table from the element from the [Control I/O Configuration](#) tab – [Group Logical Outputs](#) comprises the bit of the smallest weight, found in the digital word, rightmost. The last element from the group is the bit of the biggest weight, leftmost. A binary number created in this way corresponds to the states of relay outputs from the group, as set.

For [NO-type](#) (Normally Open) [Logical Outputs](#) – 1 is a closed output, 0 – opened. For [NO Inverted](#) relays: 1 – is an opened output, 0 – closed. For [NC-type](#) (Normally Closed) [Logical Outputs](#) – 1 is an opened output, 0 – closed. For [NC Inverted](#) relays: 1 – is a closed output, 0 – opened.

In case of a NO 2-output group, we have the following manipulation options, depending on the [State](#) value:

- State = 0 Opening of both outputs (00)
- State = 1 Closing of Output 1 and opening of Output 2 (01)
- State = 2 Opening of Output 1 and closing of Output 2 (10)
- State = 3 Closing of both outputs (11)

If we have a group of 3 logical outputs, Output 1 – [NC Normal](#), Output 2 – [NC Normal](#), Output 3 – [NC Normal](#), we have the following manipulation options, depending on the [State](#) value:

- State = 4 Out 1 close, Out 2 close, Out 3 open (100)
- State = 5 Out 1 open, Out 2 close, Out 3 open (101)
- State = 6 In 1 closed, In 2 open, In 3 open (110)
- State = 7 In 1 open, In 2 open, In 3 open (111)

3 Group element graphic view: [Preview Groups](#) – this is available under the icon . This function presents, in the form of a graphic matrix, in one table, all groups which have been created, as well as their members.

	ALARM MODE ACTIVE	FAULT YES	LO0003	LO0004	LO0005	LO0006	LO0007	LO0008	LO0009	LO0010	LO0011	LO0012	LO0013	LO0014	LO0015	LO0016	LO0017	LO0018	LO0019	LO0020	LO0021	LO0022	LO0023	LO0024	LO0025	LO0026	LO0027	LO0028	Mikrofon Strazaka_PrzyckiLO_B	Mikrofon Strazaka_PrzyckiLO_G	Mikrofon Strazaka_PrzyckiLO_GREEN	Mikrofon Strazaka_PrzyckiLO_R
LogicalOutputGroup001			●	●	●		●	●																								
LogicalOutputGroup002																																
LogicalOutputGroup003								●	●																							

13.7.3 Timers

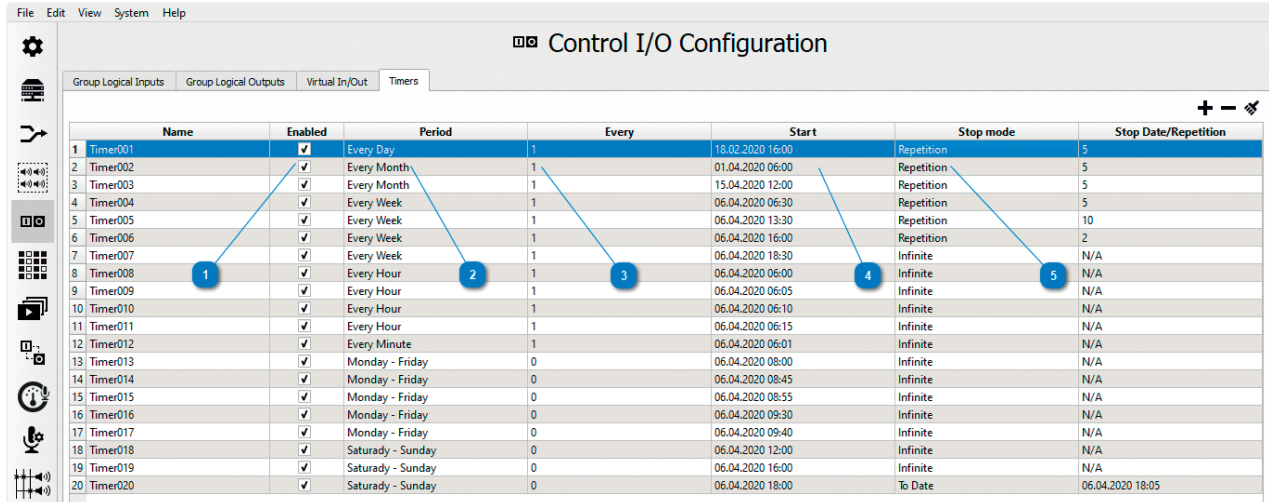

	Name	Enabled	Period	Every	Start	Stop mode	Stop Date/Repetition
1	Timer001	<input checked="" type="checkbox"/>	Every Day	1	18.02.2020 16:00	Repetition	5
2	Timer002	<input checked="" type="checkbox"/>	Every Month	1	01.04.2020 06:00	Repetition	5
3	Timer003	<input checked="" type="checkbox"/>	Every Month	1	15.04.2020 12:00	Repetition	5
4	Timer004	<input checked="" type="checkbox"/>	Every Week	1	06.04.2020 06:30	Repetition	5
5	Timer005	<input checked="" type="checkbox"/>	Every Week	1	06.04.2020 13:30	Repetition	10
6	Timer006	<input checked="" type="checkbox"/>	Every Week	1	06.04.2020 16:00	Repetition	2
7	Timer007	<input checked="" type="checkbox"/>	Every Week	1	06.04.2020 18:30	Infinite	N/A
8	Timer008	<input checked="" type="checkbox"/>	Every Hour	1	06.04.2020 06:00	Infinite	N/A
9	Timer009	<input checked="" type="checkbox"/>	Every Hour	1	06.04.2020 06:05	Infinite	N/A
10	Timer010	<input checked="" type="checkbox"/>	Every Hour	1	06.04.2020 06:10	Infinite	N/A
11	Timer011	<input checked="" type="checkbox"/>	Every Hour	1	06.04.2020 06:15	Infinite	N/A
12	Timer012	<input checked="" type="checkbox"/>	Every Minute	1	06.04.2020 06:01	Infinite	N/A
13	Timer013	<input checked="" type="checkbox"/>	Monday - Friday	0	06.04.2020 08:00	Infinite	N/A
14	Timer014	<input checked="" type="checkbox"/>	Monday - Friday	0	06.04.2020 08:45	Infinite	N/A
15	Timer015	<input checked="" type="checkbox"/>	Monday - Friday	0	06.04.2020 08:55	Infinite	N/A
16	Timer016	<input checked="" type="checkbox"/>	Monday - Friday	0	06.04.2020 09:30	Infinite	N/A
17	Timer017	<input checked="" type="checkbox"/>	Monday - Friday	0	06.04.2020 09:40	Infinite	N/A
18	Timer018	<input checked="" type="checkbox"/>	Saturday - Sunday	0	06.04.2020 12:00	Infinite	N/A
19	Timer019	<input checked="" type="checkbox"/>	Saturday - Sunday	0	06.04.2020 16:00	Infinite	N/A
20	Timer020	<input checked="" type="checkbox"/>	Saturday - Sunday	0	06.04.2020 18:00	To Date	06.04.2020 18:05

This is a function used to create elements activating given actions in the smartVES system. In order to create a timer, click the **+** icon in the [Control I/O Configuration – Timers](#) tab. In this way a timer is created with the generic name Timer00000x; the name is editable by moving the mouse cursor over it and pressing the left mouse button. **Each timer has the following set of parameters:**

- 1 **Enabled (check box)** – Timer activity window. It is used to deactivate the timer if we do not want a given event, which is triggered by the timer, to be executed, and we do not want to remove the event from the system, then to do this we deactivate a selected timer.
- 2 **Period – activation period:**
 - › [annual](#)
 - › [monthly](#)
 - › [weekly](#)
 - › [daily](#)
 - › [hourly](#)
 - › [minute](#)
 - › [\(Monday through Friday\)](#)
 - › [\(Saturday & Sunday\)](#)
- 3 **Every** – the time interval number between the activations depending which parameter is selected from the [Period](#) window. If [Every Minute](#) is selected and the [Every](#) parameter is set to 15, this means activation of the timer every 15 minutes.
- 4 **Start** – defines the exact date and time of the first activation of the timer.
- 5 **Stop** – defines ending the operation of the timer, the available options being:
 - › [To date](#) – the date and time to end activation
 - › [Infinite](#) – activation without defining the end
 - › [Repetition](#) – the exact specification of the number of repetitions

A defined timer is available in the [Event Configuration](#) tab, in the [Input](#) column, and all system functions can be assigned to it, as to zone microphone or logical input buttons.

13.8 Matrix Configuration

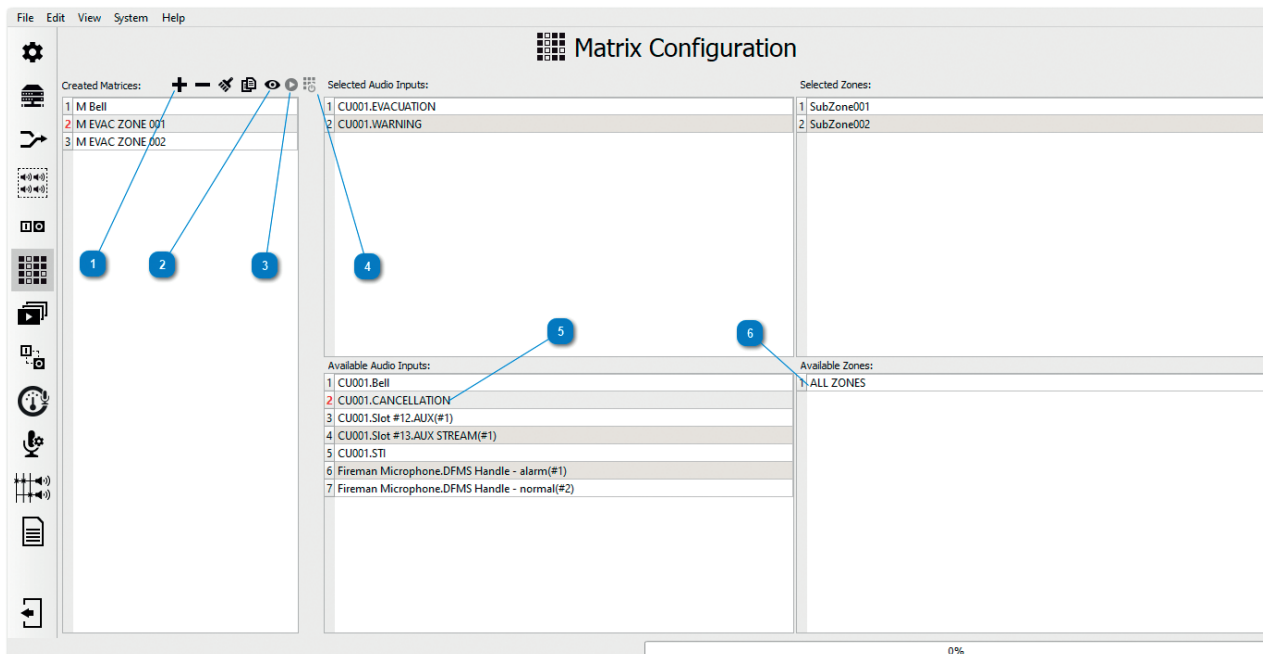

Matrix Configuration is used to create connections of all audio sources available in the system to audio outputs.



The tab has 3 sections: creating Matrices, audio sources and speaker zones or zone group.

1 Matrix editing tab

By means of the icon , a new matrix is created with a generic name which can be change by double-clicking of the left mouse button on the matrix name. Creating the first matrix in the system, we activate the available audio source and available speaker zone field.

Icon  results in deleting the marked matrix completely.

Icon  deletes all previously created matrices.

Matrix cloning function: Clone Matrices – this is available under the icon . Highlight the previously created matrix by moving the mouse cursor over its name and by clicking the left mouse button once. Then select the icon . [Clone Matrices](#) results in creating a new matrix of the identical composition as the source matrix.

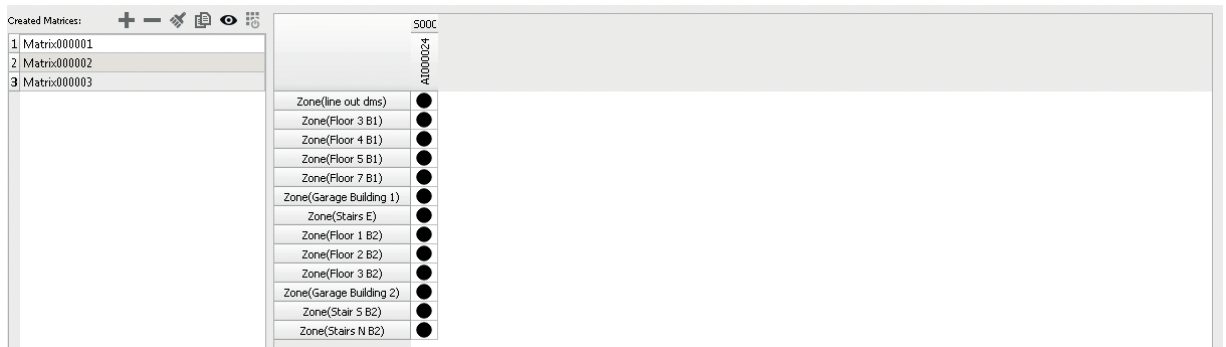

2 Matrix element graphic view: [Preview Matrices](#) – this is available under the icon . This function presents, in the form of a graphic matrix, in one table, all created connections of audio sources to the selected matrix outputs. Moving the mouse cursor over the matrix name and clicking the left mouse button once results in displaying the elements of a selected matrix in the [Preview Matrices](#) table. The output from the [Preview](#) mode is executed by a single click of the left mouse button on the icon .

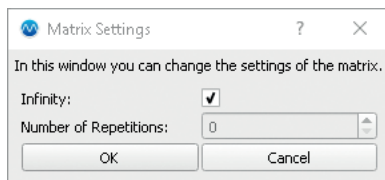

- 3 **Matrix settings** – the number of message repetitions specific to the matrix is accessible under the icon . If the **Infinity** checkbox is ticked the message is played back in a continuous loop. Untick the checkbox to gain access to setting the number of repetitions of the message with the maximum number being 100.



- 4 **Test dynamic matricing** – available under the icon . This is a service function which enables creation of dynamic audio connections from the configurator for testing/servicing purposes. This option is active only if and when the system has a configuration loaded and the computer with the configuration software is connected to the system and has the same configuration as the system. Setting a connection is executed by selecting an audio source from the first column – a single click of the left mouse button, and then selecting a speaker zone from the second column – a single click of the left mouse button, followed by selection of the **+** icon.

The  icon deletes all single connections, whereas selecting the  icon deletes all connections which have been set.

- 5 **Available Audio Inputs**
 Audio sources available in the entire system. Double-click a chosen audio source to transport it to the **Selected Audio Inputs** field.

- 6 **Available Zones**
 Available speaker zones, as declared in the system. Double-click a chosen speaker zone to transport it to the **Selected Zones** field.

In order to create a matrix correctly:

1. **Create a matrix by selecting the  icon.**
2. **Select an audio source** – a double click of the left mouse button on any element from the available audio input list.
3. **Select a zone** – a double click of the left mouse button on any element from the available zone list. Remember that it is possible to assign only one audio source to a given zone within one matrix. Adding another audio source within one matrix makes any previously used zones unavailable for successive sources as they are already used with previously defined audio inputs.

13.9 Scenario Configuration

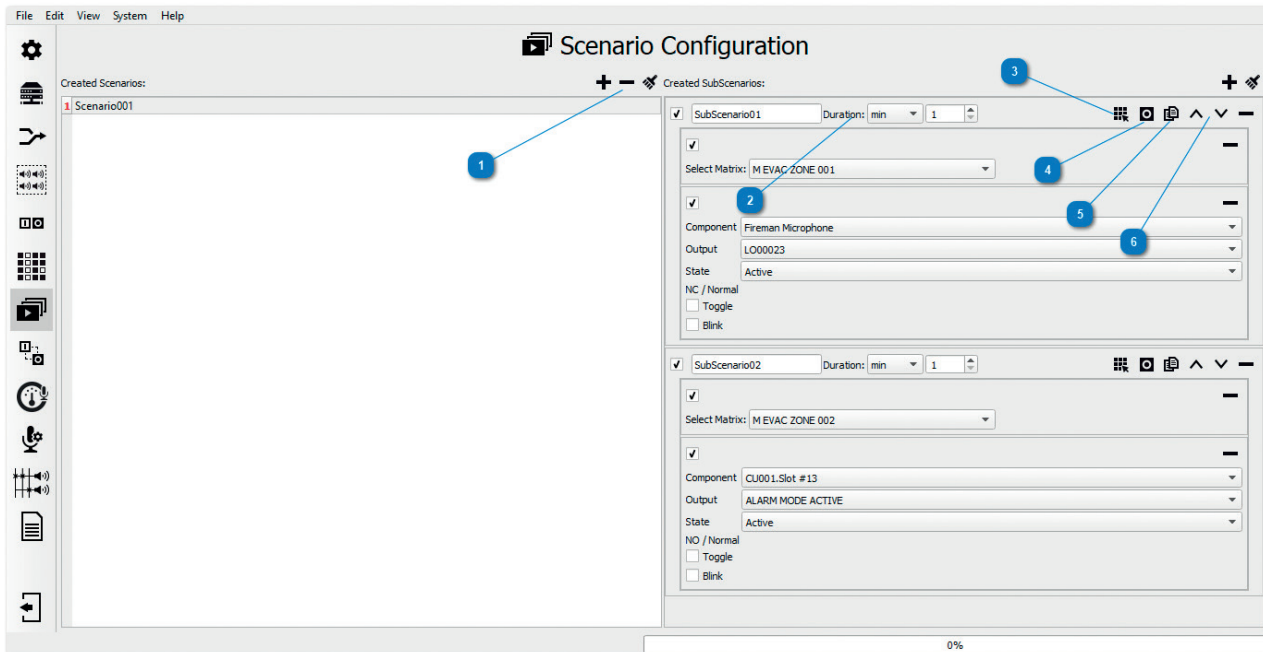

Scenario Configuration – this enables to create an event sequence that is time-limited in any way and executed one by one (SubScenario after SubScenario). Scenarios can consist of matrixes, logical (relay) outputs and individually created functions in the LUA language.

1 Scenario editing tab enables to create new scenarios, changing their names and deleting selected ones.

By means of the icon **+**, a new scenario is created, whose generic name can be changed by double-clicking the left mouse button on the scenario name.

Icon **-** results in deleting the marked scenario completely.

Icon **✖** deletes all previously created scenarios.

2 Advanced scenario editing

Each subscenario has a predefined duration (**Duration**). Available options include as follows:

- > [ms](#) – millisecond (1000 ms = 1 second)
- > [s](#) – second
- > [min](#) – minutes
- > [hours](#)
- > [days](#)
- > [weeks](#)
- > [years](#)
- > [infinite](#) (no end defined)

3 Icon **⌘** adds a matrix or a number of matrixes to a subscenario. It must be remembered that after the **Duration** time has expired, counting from activation of a given scenario, the created matrixes are deactivated.

- 4 **Icon**  **assigns available logical (relay) outputs to a subscenario.** Having added a logical output, the following windows are to be filled:

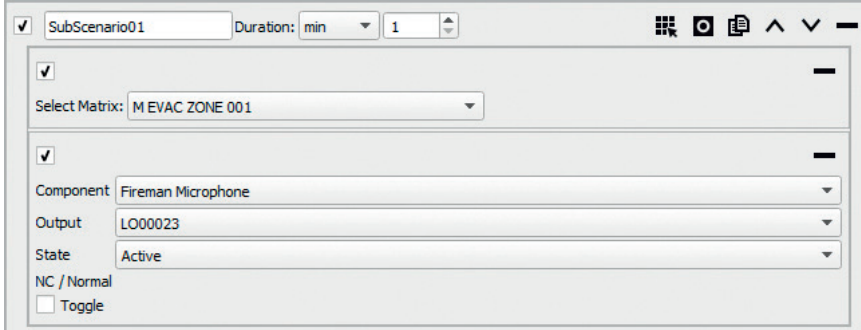

Component – select an output card or fireman microphone, a communications card containing the output we want to use.



Output – select from the list of available outputs on the device, from the **Component** tab, the output which we want to control.

State – allows to determine the final state of the relay contacts following activation. **Active** results in changing the relay state to the opposite one on execution of a scenario. For **Inactive**, the relay does not change its state when the scenario is activated.

NC/ Normal (Inverse) – informs of the initial state of a relay before activation of the function. If we set **Active** in the **State**, then activation of the scenario for an **NC/Normal** relay causes transition into **NO** – Normally Open. It must be remembered that after the **Duration** time has expired, as counted from activation of a given scenario, the assigned logical outputs remain in the state as defined in the subscenario. They do not return to the default settings.

By marking the **Toggle** option causes that each time when the output assigned to a scenario is activated, then the relay state changes into the opposite to the one which was set at an earlier activation. The default state at the first activation depends of the **State** field settings.

- 5 **Subscenario cloning function: Clone Subscenario** – this is available under the icon . A single click of the left mouse button on the icon creates a new subscenario of the identical composition as the one created before.

- 6 **Up / Down arrows**   – enable to change the order in which scenarios are executed. The order of subscenario execution by the system is top to bottom according to the times, as declared in the **Duration** window.

Scenario Delay

Scenario delay is used to delay the actions, which will be executed by programmed scenario.

When scenario will be triggered, first SubScenario will take the place. When **SubScenario01** will reach it's timeout (i.eg. 1 minute like on example below) second **SubScenario02** will take the place until it's timeout (5 minutes on example below), then the whole Scenario will be stopped.

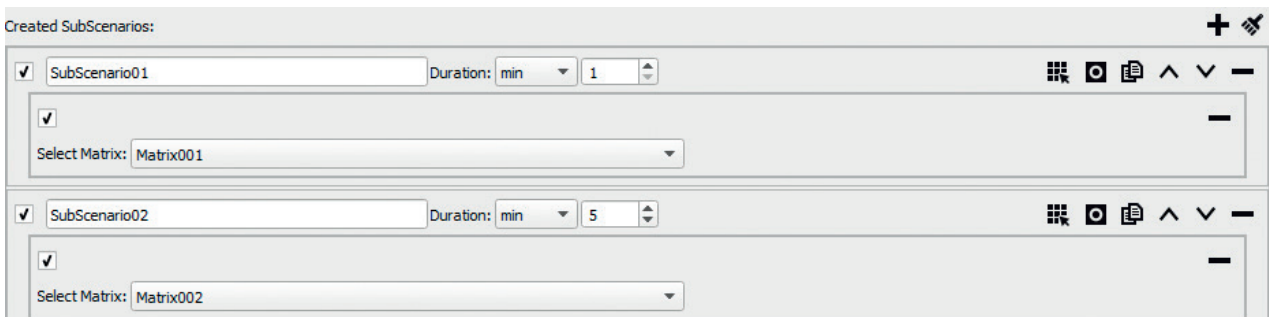

If there is a need to delay the first SubScenario01 a function called [Scenario Delay](#) can be used.

			Condition	Value	Function
1	^	v	Active	N/A	Scenario Delay

Delay time can be set between 1 second and 7200 seconds (120 minutes).

Selected Scenario:

 Delay:

 Mode:

Example:

1. Delay time is set as 7200s
2. Scenario001 is triggered by control input
3. Delay clock is counting down from 7200s to timeout
4. When 7200s will pass, Scenario001 will be started
5. SubScenario01 will be performed for 1 minute, then will be stopped
6. Subscenario02 will be performed for 5 minutes, then will be stopped
7. Scenario001 will be stopped

13.10 Event Configuration

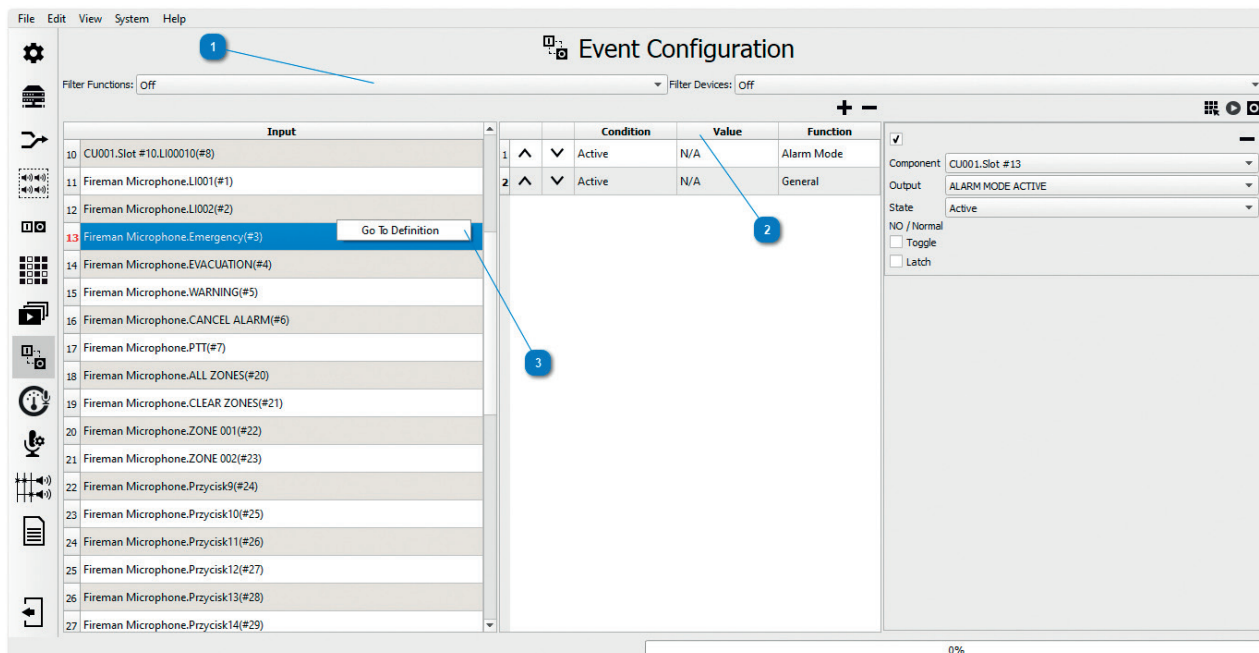

[Event Configuration](#) – this tab enables assignment of a selected system function to each logical input and button available on fireman and zone microphones, as well as scenario and matrix activation / deactivation. Moreover, in the [Event Configuration – Inputs](#) tab there are 4 system States available, to which one can assign any function, matrix, scenario, as well as define activation of relay outputs.

The signalled system states include as follows:

- » **Alarm Mode** – will activate an assigned action upon the system entering the alarm mode.
- » **Error** – will activate an assigned action upon detection of an error in the system.
- » **Blocking** – activation of an action when blocking a single speaker zone.
- » **Backup power** – activation of an action subsequent to the central unit detecting a 230 V AC power failure and switching to the emergency power source (batteries).

Assignment of any system function / action triggered by one of the above system states has been created to facilitate state signaling on any available element of the system, e.g. any output on a logic output card.

Input	
1	Alarm mode
2	Error
3	Blocking
4	Backup Power

1 The filters in the [Event Configuration](#) tab enable to search for any logical input or button sorted by the assigned function – [Filter Functions](#), sorted by the device containing the given element – [Filter Components](#) or by using available inputs – [Filter control inputs](#).

2 **In order to assign a function to any button or logical input:**

1. Select an element from the [Inputs](#) list by single-clicking the left mouse button on the element name.

Input	
1	LI000003
2	LI000004
3	LI000005 (In Group)
4	LI000006
5	LI000007
6	LI000008
7	LI000009
8	LI000010

2. Click the left mouse button once on the icon , and then select an appropriate function from the [Functions](#) column in the window. It is possible to assign many function to one button or logical input.

3 **Go to Definition** is a quick access function which is activated by clicking the right mouse button while moving over onto the name of a logical input and any button in the [Event Configuration – Inputs](#) tab. The function results in going to detailed editing of the microphone, card, microphone extension, device in which the element being edited is located.

13.10.1 Functions

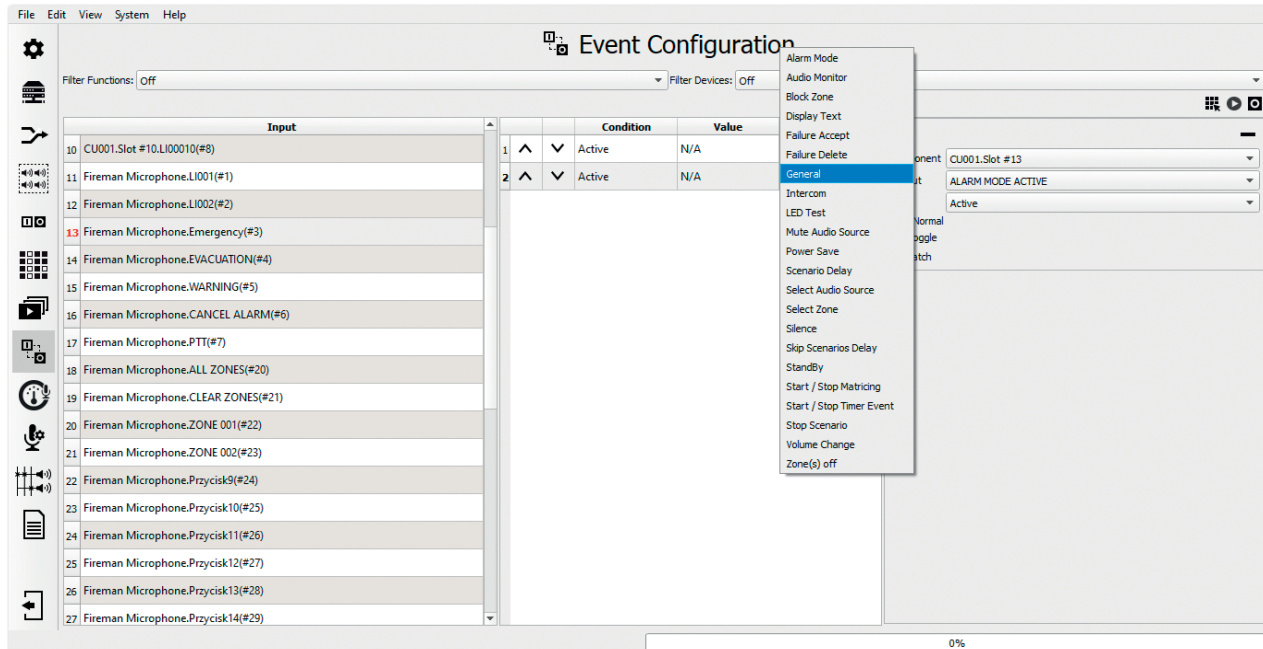

Alarm Mode

The alarm mode function results in the system entering into a detected threat warning and evacuation mode. In this mode, fireman microphones and evacuation-type messages are active. All the other sources: BGM, General, Service, are inactive until the system goes out of the alarm mode. More information of assigning type to a sound source, message or zone microphone is to be found in the [Priority Manager](#) tab. The [Alarm Mode](#) can be activated in many ways. Most frequently by the dedicated [Evacuation](#) button on the fireman microphone or any programmable logic input located on the xLogIN-8c card, on the xNET-1Gb/WAN/RS communications card and the fireman microphone. The function itself may operate in three available modes: [Start](#), [Stop](#) and [Toggle](#).

Audio Monitor

The audio monitor function enables to hear a message / audio signal, as transmitted, in any zone on the built-in speaker of the ABT-DMS and ABT-DMS-LCD zone microphones. In order to programme the function in the smartVES, select a zone which we want to preview from the [Source zone selection](#) window and from the [Target zone selection](#) window below select the zone to which the zone microphone internal speaker is assigned. In order to activate the zone microphone speaker output enter the [Zone microphone configuration](#) window in the [Audio outputs](#) table, from the first line in the [Connections](#) field select the [Output line](#). Having switched from [No connection](#) to [Output line](#), the system creates a zone whose generic name is editable in the [Name](#) window. In this way a zone has been created consisting only of a zone microphone built-in speaker which is available in the [Matrices configuration](#) tab, as well as for all functions referring to speaker zones, including the audio monitor.

Block Zone

This function can have one or many zones assigned to it. Blocking a zone results in a total lack of possibility to transmit sources to a zone or zone group, regardless of the source type. The block zone is signalled by a constant, yellow LED on the button programmed as [Zone selection](#) having the highest signaling priority.

Custom

The window of this non-standard function enables to create, programme one's own function or series of actions for the system to execute. The code of the programme which is to be placed in the [Custom](#) field must be consistent with the syntax of the LUA language and refer to variables, functions and libraries defined by the Ambient System in the LUA language implementation instructions in the smartVES system.

Display Text

Activation of the display text function opens a dialogue box on a selected and available GUI screen in the system and prompts display of the text entered into the [Text to display](#) window.



Failure Accept

This is a global function which mutes the acoustic signalization of a failure within the entire system. The moment any failure occurs in the system, the yellow LED on the failure accept button blinks additionally on each element of the system equipped with a GUI, the buzzer goes off as well. Having accepted the failure, the yellow LED is lit and the persistent acoustic signal stops.

Failure Delete

Deleting a failure is a global function affecting the entire system. The function is active only if and when the system is in the failure status. Activation of the [Failure delete](#) results in resetting of the system element in which the failure was detected, and then running the system test procedure.

General

This function combines three main functionalities of the smartVES system: [Scenarios](#) , [Matrices](#)  and [logical outputs](#) , alongside an access to RGB LED behaviour programming on zone microphones. The [General](#) function enables to assign to a logical input or a button of any defined scenario, matrix combination, alongside a possibility to define system LED and logical output activation in an individual way.

If in the [General](#) function, the icon  is selected, then this function is assigned a matrix. Activation of the general function enables to activate or deactivate one or multiple matrices defined in the system, using one logical input or button on a zone/fireman microphone. Each matrix can have an individual activation mode assigned to it – [start](#) / [stop](#) / [toggle](#).

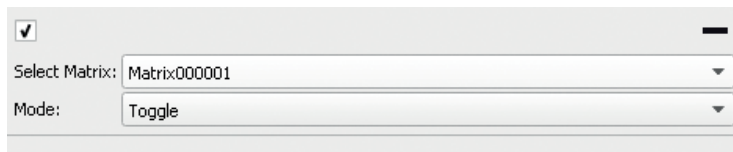

If in the [General](#) function, the icon  is selected, then this function is assigned a scenario. Activation of the general function enables to activate or deactivate scenarios using one logical input or button on a zone/fireman microphone. Each scenario can have an individual activation mode assigned to it – [start](#) / [stop](#) / [toggle](#).

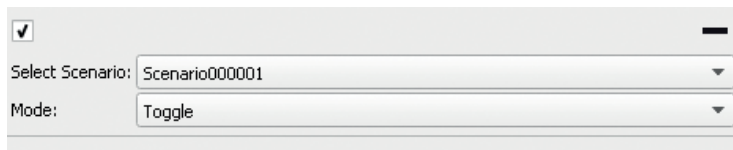

If in the [General](#) function, the icon  is selected, then this function is assigned a selected logical/relay output. The figure below presents the options, as available:



[Component](#) – enables to select an output card or fireman microphone from the list, a communications card containing the output we want to use.

Output – enables to select from the available output list on the device, from the **Component** tab, an output which we want to control.

State – allows to determine the final state of the relay contacts following activation. **Active** results in changing the relay state to the opposite one on execution of the **General** for **Inactive**, the relay does not change its state when the **General** is activated.

NC/ Normal (Inverse) – this field informs of the initial state of a relay before activation of the function. If we have **Active** in the **State**, then activation of the **General** function for an **NC/Normal** relay causes transition into **NO** – Normally Open. If we have **Active** in the **State**, then activation of the **General** function for an **NC/Invers** will cause transition into **NC** – Normally Closed.

By marking the **Toggle** option causes that each time when the output assigned to the **General** is activated by such a system element as a logical input or button on a zone microphone, the relay state changes into the opposite to the one which was set at an earlier activation. The default state at the first activation depends of the **State** field settings.

Latch

Marking the **Latch** option results in a relay output changing its status to the opposite one than specified in the information field located below the **State** tab (see Figure below) on the first activation of the **General** function.

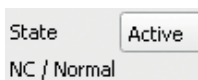

The relay does not change its state into the opposite one, does not return to the settings defined in the relay information field on deactivation of the **General** function.

Intercom

This function sets up an intercom connection between two microphones available in the system. The **Select microphone from** field is automatically migrated by the device containing the key we are assigning the intercom function to. In the **Select microphone to** field the recipient of the intercom connection should be chosen. The **Enable sound when call appears** checkbox lets the user define the acoustic signals for the connection, **Select the sound for initialization of call** being the sound we hear while waiting for the recipient to answer the call on the device that initializes it. The **Select sound for incoming call** field defines the sound we hear on the device being a recipient of an awaiting connection.

LED test

The LED test function activates all LEDs on the element to which it is assigned. In addition, activation of this function on the fireman microphone triggers the warning buzzer signal. The function can be activated in three modes.

Mute audio source

This function mutes one selected audio source in all matrices to which it is assigned. In the **Source selection** window, select from the available and defined audio inputs, microphones and messages in the system to define the function correctly. Stopping the **Mute audio source** function results in turning up the audio source volume to the full level and restoring the matrices to the state before activation of the mute function.

Power Save

The power save function disconnects all active BGM and General-type sources. The function is activated by dynamic assignment. The function can be activated in three modes. Deactivation of the **Power Save** function results in restoring the previously disconnected sources.

Record Message

This function is used to record messages directly from the ABT-DMS, ABT-DMS-LCD zone microphones without having to connect to the system via dedicated software and during the system's normal operation. Messages are recorded in the flash microSD memory on the control unit to which the zone microphone is directly connected. Message recording is signalled by a red LED at the **Record Message** button. The function records a message into a file whose name is defined in the configurator, in the **Message** window. In case of filling up the memory, this is signalled by a yellow LED. Replaying of a recorded message is executed via the **Select Audio source** function for which one of the predefined names is assigned from the list: Message1, Message2, Message3.

Scenario Delay

This function causes a time delay in the scenario execution. The maximum time to declare a delay in a scenario execution is 600 seconds. In order to execute the scenario with a delay, activate the scenario delay function and then activate scenario execution via the [General](#) function. The period of the delay from the moment of activation of a scenario is signalled by a purple LED blinking.

Select audio source

This function enables easy execution of the [dynamic matricing](#) function. Dynamic matricing consists of creating a matrix (combining a source to speaker lines) from a zone microphone or GUI in any configuration according to the user's current needs. The following items can be assigned as an audio source: messages, fireman microphones and all available zone microphones and their audio inputs. In order to initiate dynamic matricing, select dedicated [Zone selection](#) buttons in the given order: highlight the zone or zone group to which we want to transmit to, then – using the [Source selection](#) button – initiate transmission of the programmed source into the selected zones.

Select Zone

The zone selection function serves to assign one zone or a zone group to a selected button. Having selected the function in the configurator, assign the selected zone in the [Select Zone](#) field, and then select one of the activation modes.

Silence

This is a global function which deletes all active sound sources of the [BGM](#) or [General](#) priorities. This function is available only for logical inputs and the ABT-DFMS fireman microphone buttons and may be activated even if the fireman microphone is not in the alarm mode. If the [Silence](#) mode is active (a red LED on the microphone at the [Silence](#) function button is on), then BGM and General matrices cannot be activated. Deactivation of the function unblocks priority matricing.

Skip Scenarios Delay

This is a global function and results in prompt execution of all scenarios for which the delay time countdown has started (purple LED blinking).

Stop Scenario

The function results in stopping execution of a scenario, as declared in the configurator. The scenario stop causes switching off all active matrices included in the scenario, whereas the status of the relay outputs which might have been a part of the scenario remains consistent with the programmed state at the moment of stopping the scenario.

Start/stop matricing

The function enables activation or deactivation, via one logical input or button on the zone/fireman microphone, of one or many matrices, as defined in the configurator. Each matrix can be assigned an individual activation mode – [start](#) / [stop](#) / [toggle](#).

Zone(s) off

The function acts on the principle of dynamic assignment, i.e. in order to activate the function, one needs to follow a predefined order. The first activity is to select a zone or many zones using the programmed button [Select Zone](#), then the [Zone\(s\) off](#) button is selected. Thus activated, the function causes irreversible disconnection of all active sound sources of [BGM](#), [General](#), [Service](#) priorities.

External Fault CIN

The [External fault CIN](#) can only be assigned to a system logical input. Having activated the logical input to which the function is assigned, in the fault window on the GUI, as well as in system logs, an entry will be displayed with the name of the logical input. Change the name of the logical output in order to identify the fault-reporting device in an unequivocal way.

Volume change

The volume change function controls levels of audio outputs and inputs in the smartVES system. The function is activated by dynamic assignment. There are two methods of volume change execution in the configurator:

1. **Change** – the level of signal at an audio output will be decreased or increased by the value declared in decibel in the **Volume** window compared to the level set in the audio output individual configuration window. Each successive activation of the function within the Change mode results in a decrease or increase by the value with respect to the level having been set.
2. **Set** – the level of the signal of an audio output will be set to the value declared in decibel in the **Volume** window.

If the control unit utilizes only matricing using common HVaudioBus, then the **Volume change** function is not active.

The volume can be adjusted in two modes, depending on the choice of the place where it will be performed:

- » **Volume Output**: the adjustment is made on the audio card outputs and applies to all audio signals
- » **Volume Input**: the adjustment is made only on the audio card inputs and applies to external audio signals connected to dedicated inputs in ABT-ISLE modules.

Additionally in the **Select zone selection mode** field you can choose between:

- » **Selected zones** – meaning that dynamic assignment is being applied. Choose the zones by pressing the dedicated zone selection button and then use the volume change function.
- » **Defined zones** – meaning that the zones affected by the function are predefined. In this mode the volume control is activated immediately after pressing the assigned button with no need of selecting the zones. To predefine affected zones double-click the desired items in the **Available zones** field.

Volume(in dB):	3
Select change type:	Change
Select source:	Volume Output
Select selection mode:	Select
Defined:	Available:
	1 ALL ZONES
	2 SubZone001
	3 SubZone002
	4 SubZone003
	5 SubZone004
	6 ZONE 001
	7 ZONE 002
	8 ZONE 003
	9 ZONE 004

Speech correction

The speech correction function is only available in systems equipped with the SMART-DU1604 processor. It allows you to define the audio inputs from which transmitted messages will be subject to intelligibility correction. Zones which are not to be included in the speech correction mechanism can be excluded in the configuration process.

Condition	Value	Function
Active	N/A	Speech Correction

Mode:	Toggle
Select selection mode:	Define
Defined Audio Inputs:	Audio Inputs:
1 Audio_in_JSLE	1 Audio_in_JSLE
2 DFMS Normal	2 DFMS Alarm
Excluded Groups/Zones:	Available zones:
1 Zone1	1 All zones
	2 Zone2

13.11 System notifications

Description of the System Notifications tab

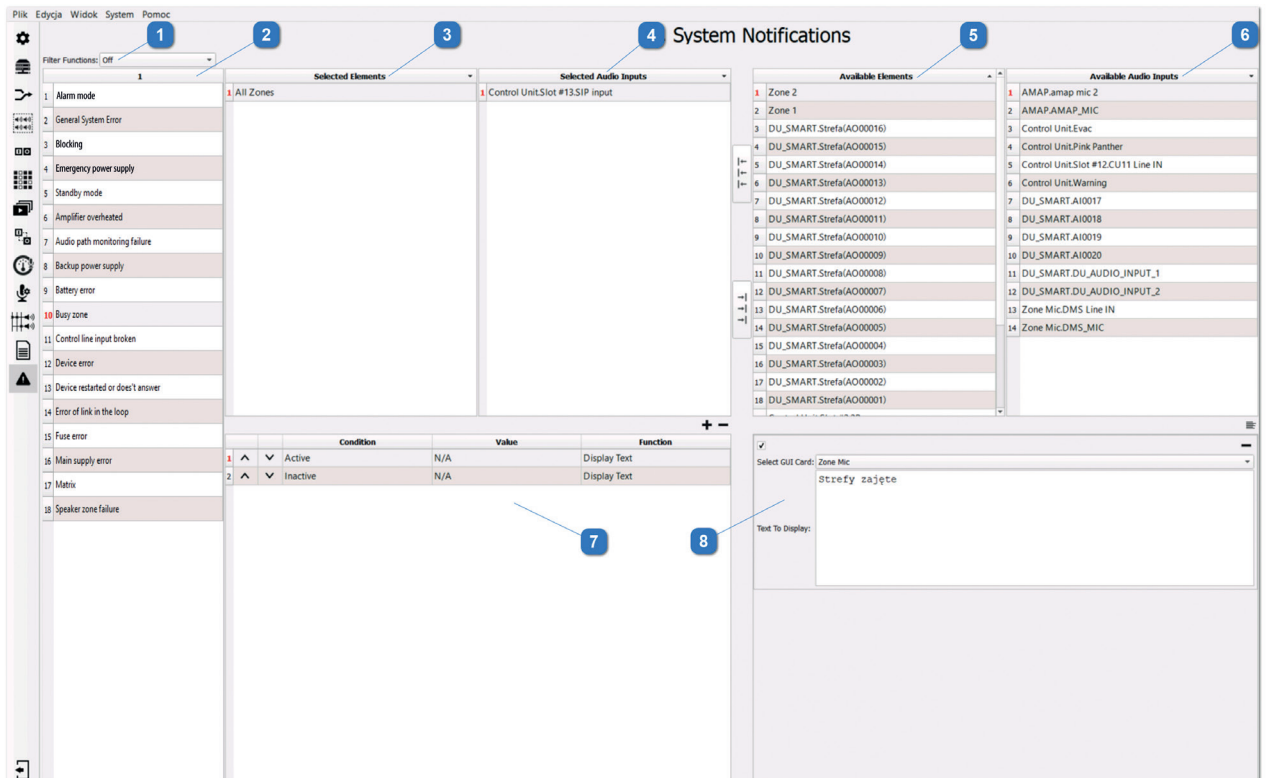

The screenshot shows the 'System Notifications' configuration window. It features a left sidebar with a list of system events (e.g., Alarm mode, General System Error, Blocking, Emergency power supply, Standby mode, Amplifier overheated, Audio path monitoring failure, Backup power supply, Battery error, Busy zone, Control line input broken, Device error, Device restarted or doesn't answer, Error of link in the loop, Fuse error, Main supply error, Matrix, Speaker zone failure). The main area is divided into several sections: 'Selected Elements' (1), 'Selected Audio Inputs' (2), 'Available Elements' (3), and 'Available Audio Inputs' (4). A table at the bottom (5) shows the configuration for selected elements, with columns for Condition, Value, and Function. Callout 6 points to the 'Available Audio Inputs' list, callout 7 to the table, and callout 8 to the 'Text To Display' field.

Condition	Value	Function
Active	N/A	Display Text
Inactive	N/A	Display Text

[System notifications](#) - allows to assign specific functions/actions to system events and states.

- 1 **Filter Functions** - Filters system events and states for the associated function.
- 2 **Input** - A list of system events and states, allowing to assign specific actions.
- 3 **Selected Elements** - List of selected devices or system components.

- 4 [Selected Audio Inputs](#) – List of selected audio sources.
- 5 [Available Elements](#) – List of available devices or system components.
- 6 [Available Audio Inputs](#) – List of available audio sources.
- 7 [Function/action window](#) – Allows to add/remove features to the selected item.
- 8 [Window for editing function/action parameters](#) – Allows to edit the parameters of the selected function/action.

List of available system states and events:

[Standby mode](#)

Trigger the assigned action when the system enters Standby mode.

[Alarm Mode](#)

This will trigger the assigned action when the system enters alarm mode.

[General System Error](#)

This will trigger the assigned action when an error is found in the system.

[Blocking](#)

Trigger action when a single speaker zone is blocked.

[Emergency power supply](#)

Trigger action when the system detects the loss of 230 AC power and switches to emergency power.

[Amplifier overheated](#)

Triggering of the assigned action upon receipt of overheating information from the amplifier.

[Audio path monitoring failure](#)

Trigger the assigned action when a single audio track interrupt error occurs.

[Backup power supply](#)

Trigger the assigned action when the selected power manager (PSM48) signals the loss of 230V AC power and switches to emergency power.

[Battery error](#)

Trigger the assigned action when the selected power supply manager (PSM48) diagnoses battery damage/disconnection.

[Busy zone](#)

Triggering of the assigned action in the busy state of a specific zone (zone group/zone/single loudspeaker line).

[Control line input broken](#)

Triggering of the assigned action upon detection of a fault in a control line connected to a logical input (for lines with active Monitor mode).

[Device restarted or doesn't answer](#)

Triggering of the assigned action when a device is in reboot mode or does not respond in the internal communication network of the system.

[Error of link in the loop](#)

Trigger an assigned action when a device reports a fiber loop link error.

[Fuse error](#)

Triggering of the assigned action when an amplifier fuse failure is reported.

Device error

Triggering of the assigned action when a general error is reported by the selected device.

Main supply error

Triggering of the assigned action when the selected power manager (PSM48) detects the loss of 230 AC power.

Matrix

Triggering of the assigned action upon activation/deactivation of the selected matrix.

Speaker zone failure

Triggering of the assigned action upon detection of a fault in a specific zone (group of zones/zone/single loudspeaker line).

Configuring System Notifications

In order to assign a function/action to any system state or event:

1. Select an event or system status from the [Input](#) column.
2. From the [Available Elements](#) or [Available Audio Inputs](#) columns, select (double-click) the device/element or audio source.
3. By clicking select the desired item.
4. In the Function/Action Window, click on the icon  to add a function, available from the drop-down list in the [Function](#) column.

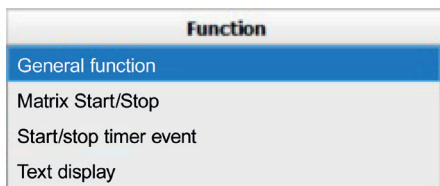

5. Set the required parameters in the [Condition](#) column and (if available) in the [Value](#) column.
6. In the [Edit Function/Action Parameters](#) Window, complete the parameter configuration of the selected function/action.

13.12 Reports

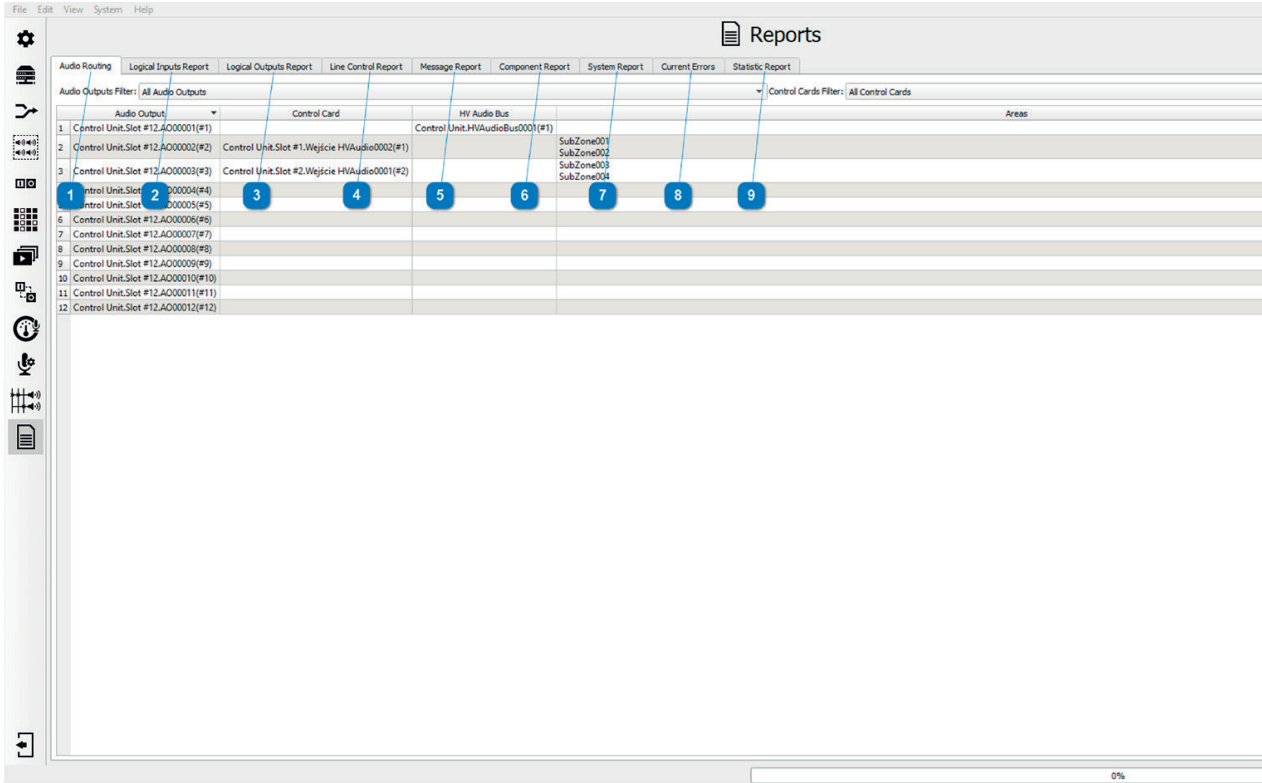

- 1 **Routing audio** – this is the list of all audio connections in the system.
- 2 **Logical Input Report** – this is a list of all logical inputs with information about the current operating mode NO / NC.
- 3 **Logical Output Report** – this is a list of all logical outputs with information about the current operating mode NO / NC.
- 4 **Line Control Report** – the list of measured impedance references saved in the system.
- 5 **Message Report** – lists all messages loaded into the system.
- 6 **Component Report** – a quantitative list of all cards, zone/fireman microphones, touch screens included in the smartVES system. In addition, there is a summary of available audio inputs and outputs, logical inputs and individual component software versions.
- 7 **System Reports** – a list of all failures and software events that occurred during normal operation. The system is capable of storing and reading over 100 thousand single events. An advanced filtering method, using date, unit and system state, makes it much easier to identify a problem which occurred in the system.
- 8 **Current errors** – list of current errors in the system.
- 9 **Statistic Report** – enables displaying of all available service data from diagnostic modules located on SFP slots. This is a unique function which shortens the time needed to verify the quality of the optical fibre and eliminate communications faults by displaying, among others, the strength of the signal transmitted and received, the number of lost packages or the internal temperature of the SFP insert.

13.13 Basic steps required for programming of the system

To program the basic version of the smartVES system it is recommended to follow the list of steps shown below:

1. Create a new project by the [New configuration](#) button . This will create a folder in which all configuration data will be saved.

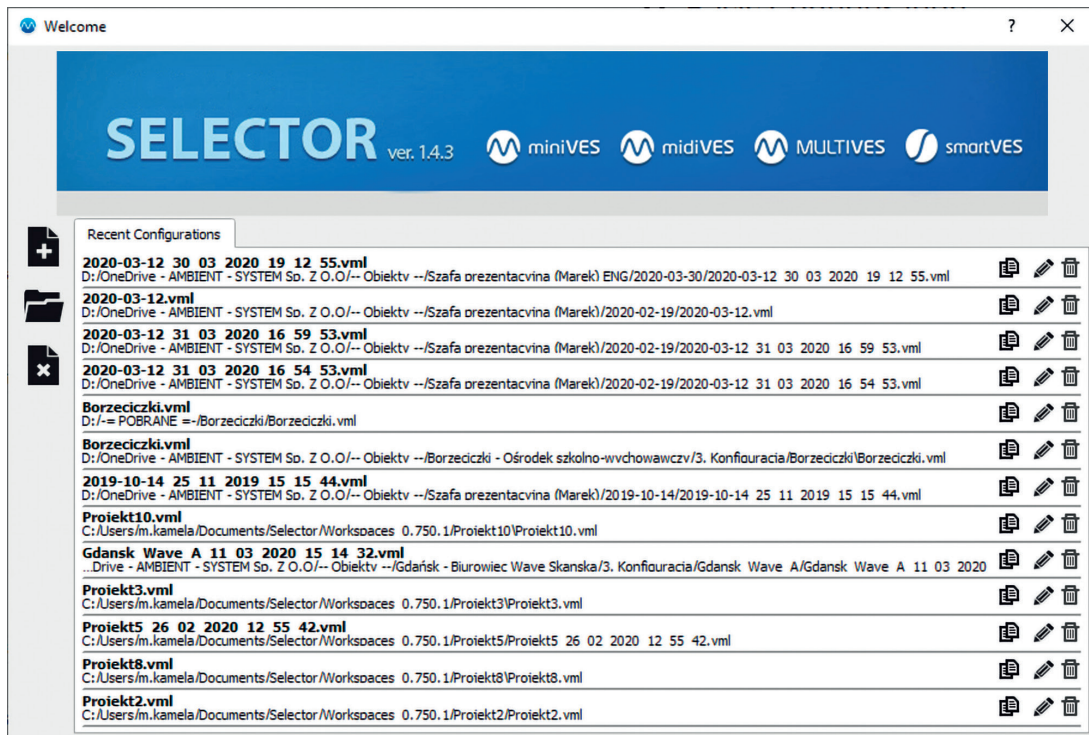

2. Connect the computer's network card with smartVES Selector software to the port labeled LAN/WAN on the control unit or DFMS (from firmware version 0.750.1, communication via the LAN / WAN port is done using an encrypted protocol).
3. To connect to the system, go to the [System](#) tab and then click [Connection Settings](#).
If the smartVES server did not appear – read FAQ 1.

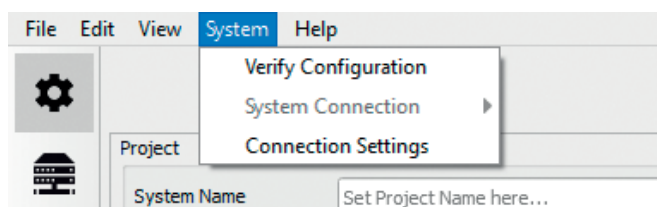

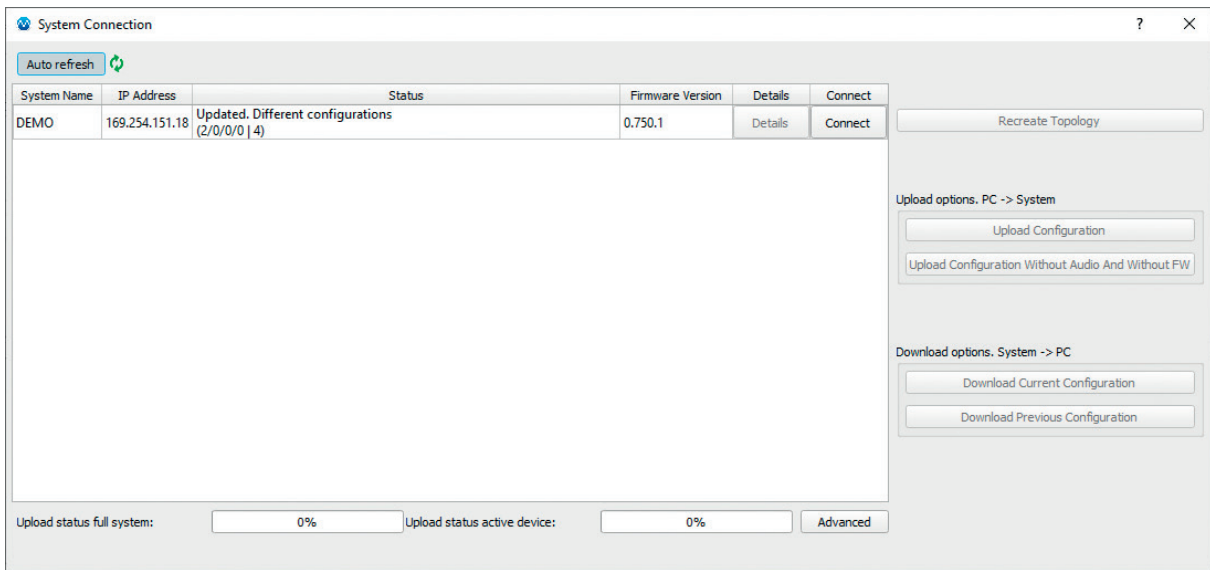

Correct connection with the system will result in highlighting the green status field and displaying the Connected status.

System Name	IP Address	Status	Firmware Version	Details	Connect
DEMO	169.254.151.18	Updated. Different configurations (2/0/0/0 4) Connected	0.750.1	Details	Disconnect

The [Restart](#) and [Restore defaults](#) functions can now be found by clicking the [Advanced](#) button, then select the checkbox [Enable service functions](#).

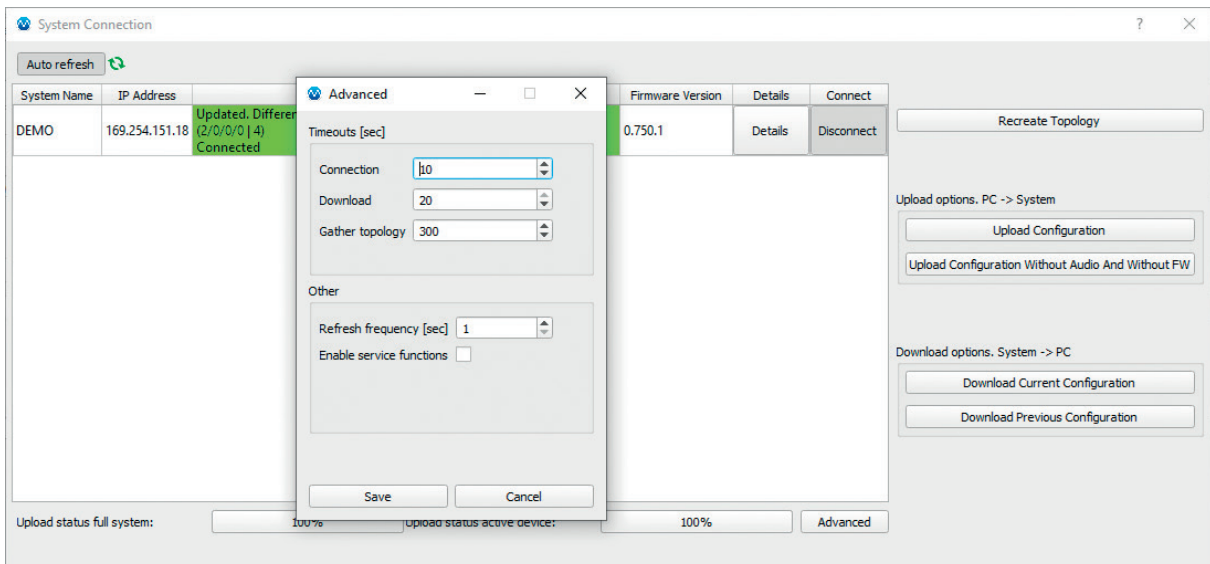

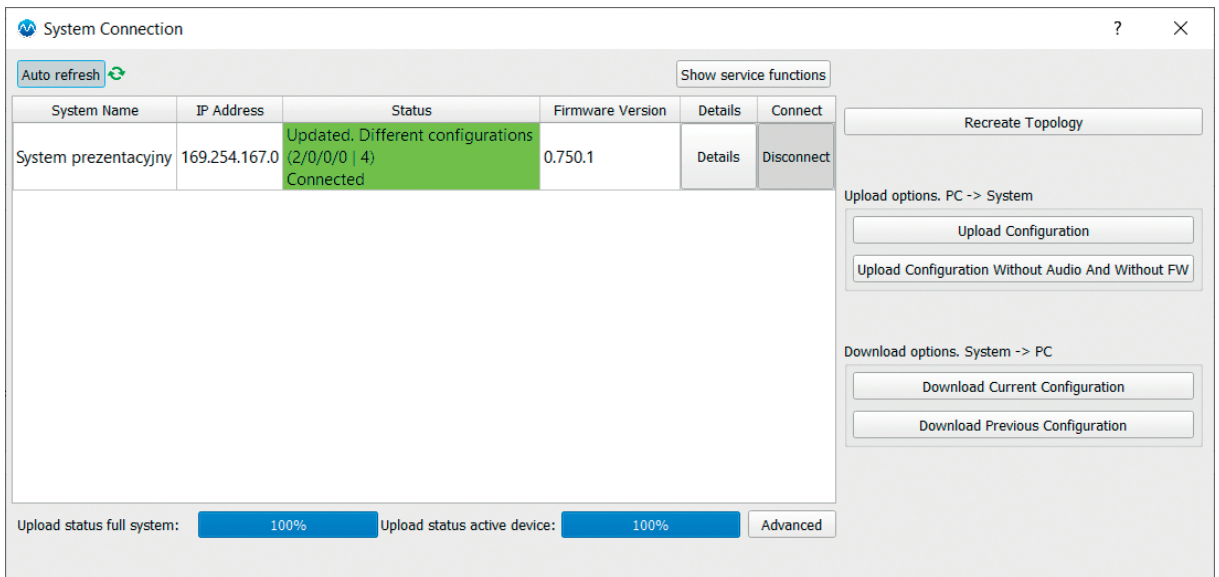

After this operation, the [Show service functions](#) icon will appear at the top of the connection window.

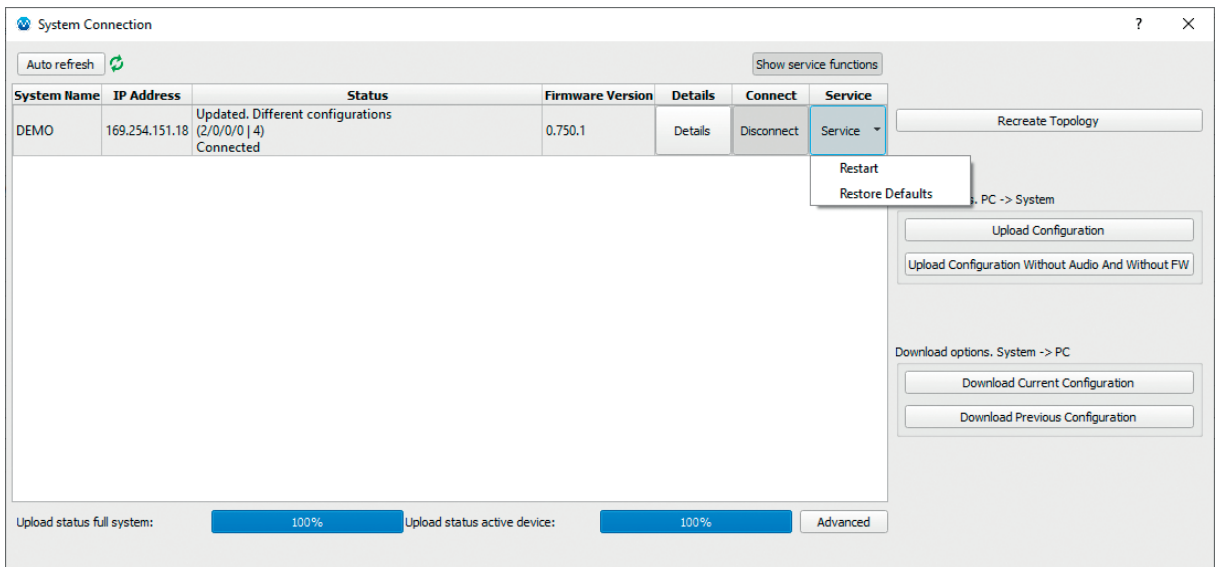

After pressing it, the [Restart](#) and [Restore Default](#) functions will appear.



- Download the topology of devices available in the system by pressing the [Recreate Topology](#) in the [System Connection](#).
- Complete the basic data in the fields: [Project Name](#), [Author](#) and switch [Configurator mode](#) to [Advanced](#) in [Basic Configuration](#) tab  .

- Go to [System Configuration](#) tab , verify that all smartVES system devices have been displayed in the expected fields of workspace and according to the method of connection (fiber/twisted pair Cat 5e SF/UTP).

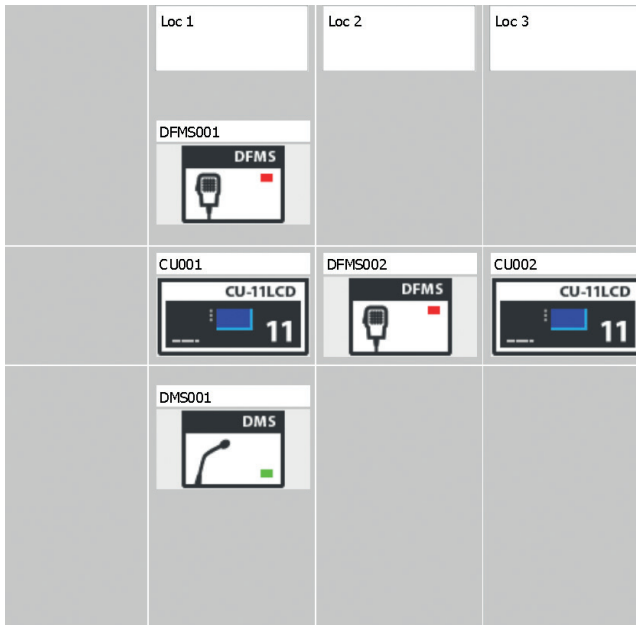

- By double-clicking the left mouse button on the control unit go to view window of unit slots.

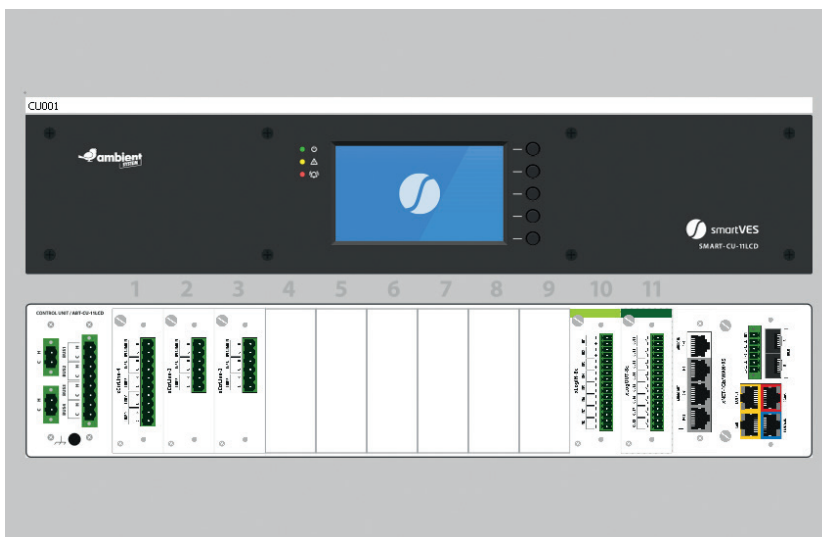

8. By double-clicking the left mouse button on the audio in/out card we define how to connect the amplifiers to unit (choose the option Bus 1-4 – HVAudioBusXXX or individual 100 V inputs on control cards – HVAudioInputXXX). The definition of **Connection** fields is required for proper operation of the System because without that the control unit does not have any information on the route that can transmit a signal onto the selected speaker zone.

Audio Outputs										
	Name	Connection	Pilot Active	Feedback Destroyer	AMP Monitoring	Volume	Delay	Limiter Threshold	DSP	Limiter Status
1	AO00001(#1)	HVAudioBus0001(#1)	<input checked="" type="checkbox"/>	<input type="checkbox"/>	<input checked="" type="checkbox"/>	-15.00 dB	0 ms	0.00 dB	Configure	<input type="checkbox"/>
2	AO00002(#2)	HVAudioInput0001(#1)	<input checked="" type="checkbox"/>	<input type="checkbox"/>	<input checked="" type="checkbox"/>	-15.00 dB	0 ms	0.00 dB	Configure	<input type="checkbox"/>
3	AO00003(#3)	HVAudioInput0002(#2)	<input checked="" type="checkbox"/>	<input type="checkbox"/>	<input checked="" type="checkbox"/>	-15.00 dB	0 ms	0.00 dB	Configure	<input type="checkbox"/>
4	AO00004(#4)	Not Connected	<input type="checkbox"/>	<input type="checkbox"/>	<input type="checkbox"/>	0.00 dB	0 ms	0.00 dB	Configure	<input type="checkbox"/>
5	AO00005(#5)	Not Connected	<input type="checkbox"/>	<input type="checkbox"/>	<input type="checkbox"/>	0.00 dB	0 ms	0.00 dB	Configure	<input type="checkbox"/>
6	AO00006(#6)	Not Connected	<input type="checkbox"/>	<input type="checkbox"/>	<input type="checkbox"/>	0.00 dB	0 ms	0.00 dB	Configure	<input type="checkbox"/>
7	AO00007(#7)	Not Connected	<input type="checkbox"/>	<input type="checkbox"/>	<input type="checkbox"/>	0.00 dB	0 ms	0.00 dB	Configure	<input type="checkbox"/>
8	AO00008(#8)	Not Connected	<input type="checkbox"/>	<input type="checkbox"/>	<input type="checkbox"/>	0.00 dB	0 ms	0.00 dB	Configure	<input type="checkbox"/>
9	AO00009(#9)	Not Connected	<input type="checkbox"/>	<input type="checkbox"/>	<input type="checkbox"/>	0.00 dB	0 ms	0.00 dB	Configure	<input type="checkbox"/>
10	AO00010(#10)	Not Connected	<input type="checkbox"/>	<input type="checkbox"/>	<input type="checkbox"/>	0.00 dB	0 ms	0.00 dB	Configure	<input type="checkbox"/>
11	AO00011(#11)	Not Connected	<input type="checkbox"/>	<input type="checkbox"/>	<input type="checkbox"/>	0.00 dB	0 ms	0.00 dB	Configure	<input type="checkbox"/>
12	AO00012(#12)	Not Connected	<input type="checkbox"/>	<input type="checkbox"/>	<input type="checkbox"/>	0.00 dB	0 ms	0.00 dB	Configure	<input type="checkbox"/>

9. Through the  icon located in the upper right corner we return to step no. 7. By double-clicking on the **Buses** sections, we go to the **Buses** editing, declaring the PSM amount connected to the given unit and we add messages that we want to upload together with the configuration.

Name: CU001			
Serial Number: B18W04501190		MAC Address: 02:00:00:AC:11:37	
HV Audio Buses			
Name	Backup	Individual AMP	Control
1 HVAudioBus0001(#1)	<input checked="" type="checkbox"/>	<input checked="" type="checkbox"/>	<input checked="" type="checkbox"/>
2 HVAudioBus0002(#2)	<input type="checkbox"/>	<input type="checkbox"/>	<input type="checkbox"/>
3 HVAudioBus0003(#3)	<input type="checkbox"/>	<input type="checkbox"/>	<input type="checkbox"/>
4 HVAudioBus0004(#4)	<input type="checkbox"/>	<input type="checkbox"/>	<input type="checkbox"/>
PSM's Settings			
Select number of psm: 0			
Message Name	File Name	Volume	Global
1 EVACUATION	Ewakuacja bez uz wind pol ang.mp3	0.00 dB	<input checked="" type="checkbox"/>
2 CANCELLATION	Odwolanie pol ang.mp3	0.00 dB	<input checked="" type="checkbox"/>
3 WARNING	Ostrzezenie pol ang.mp3	0.00 dB	<input checked="" type="checkbox"/>
4 STI	STIkrotki3min.mp3	0.00 dB	<input checked="" type="checkbox"/>
5 Bell	Bell 1x.mp3	0.00 dB	<input checked="" type="checkbox"/>
			Replace File

- Through the  icon located in the upper right corner we return to step no. 7. By double-clicking on [Slot1](#) we begin editing of control cards placed in the given unit. We should give names to zones, assign appropriate card outputs (A, B, C, D) and turn on line impedance monitoring. Repeat that action for each of control cards. Cards xLogIN and xLogOUT should be ignored – they will be edited in the final programming phase after defining matrices and scenarios.

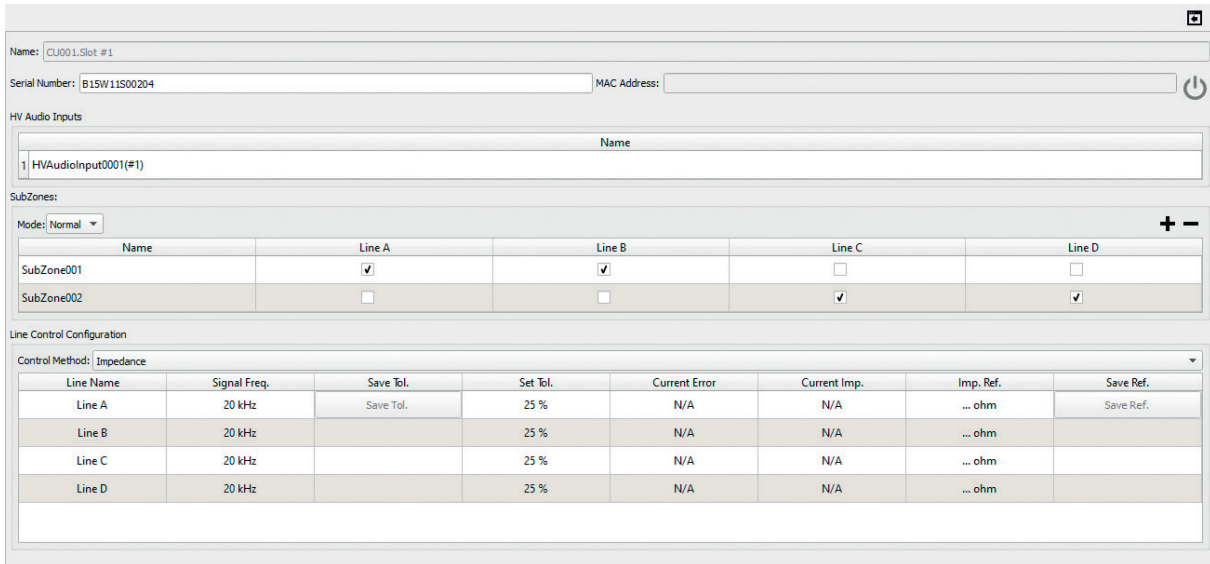

Name: CU001.Slot #1

Serial Number: B15W11S00204 MAC Address:

HV Audio Inputs

Name
1 HVAudioInput001(#1)

SubZones:



Mode: Normal + -

Name	Line A	Line B	Line C	Line D
SubZone001	<input checked="" type="checkbox"/>	<input checked="" type="checkbox"/>	<input type="checkbox"/>	<input type="checkbox"/>
SubZone002	<input type="checkbox"/>	<input type="checkbox"/>	<input checked="" type="checkbox"/>	<input checked="" type="checkbox"/>

Line Control Configuration

Control Method: Impedance

Line Name	Signal Freq.	Save Tol.	Set Tol.	Current Error	Current Imp.	Imp. Ref.	Save Ref.
Line A	20 kHz	Save Tol.	25 %	N/A	N/A	... ohm	Save Ref.
Line B	20 kHz		25 %	N/A	N/A	... ohm	
Line C	20 kHz		25 %	N/A	N/A	... ohm	
Line D	20 kHz		25 %	N/A	N/A	... ohm	

- Go to the [Priority Manager](#)  tab. Select the appropriate type of priority. Keep in mind that messages such as [Emergency](#) are played only if the system is in [Alarm](#) state. Messages /audio sources such [BGM](#), [General](#), [Service](#) are played only when the system is in [Normal](#) mode.
- Group speaker zones in .
- Define matrices, which are to be created during the evacuation and during normal operation of the system – e.g. music for zones.

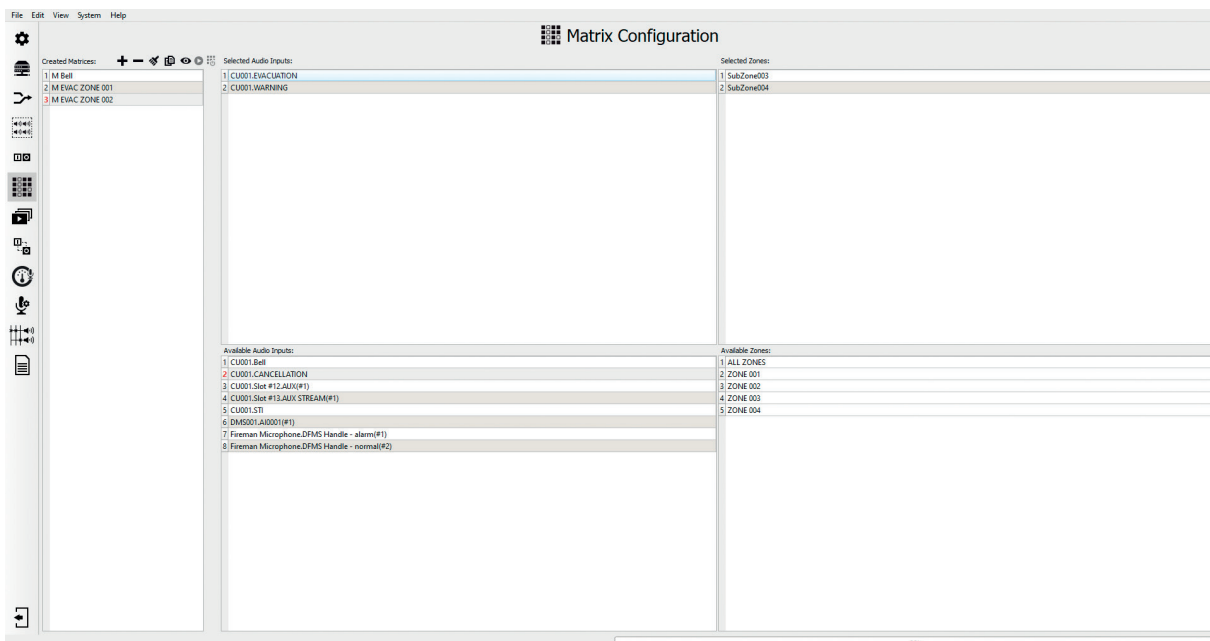

File Edit View System Help

Matrix Configuration

Created Matrices: + - 

- 1 M.BGM
- 2 M.EVAC ZONE 001
- 3 M.EVAC ZONE 002

Selected Audio Inputs:

- 1 CU001.EVACUATION
- 2 CU001.WARNING

Available Audio Inputs:

- 1 CU001.BGM
- 2 CU001.CANCELLATION
- 3 CU001.Slot #12.AUX(#1)
- 4 CU001.Slot #13.AUX.STREAM(#1)
- 5 CU001.SI
- 6 DIMS001.AIR001(#1)
- 7 Fireman Microphone.DFMS Handle - alarm(#1)
- 8 Fireman Microphone.DFMS Handle - normal(#2)



Available Zones:

- 1 all ZONES
- 2 ZONE 001
- 3 ZONE 002
- 4 ZONE 003
- 5 ZONE 004

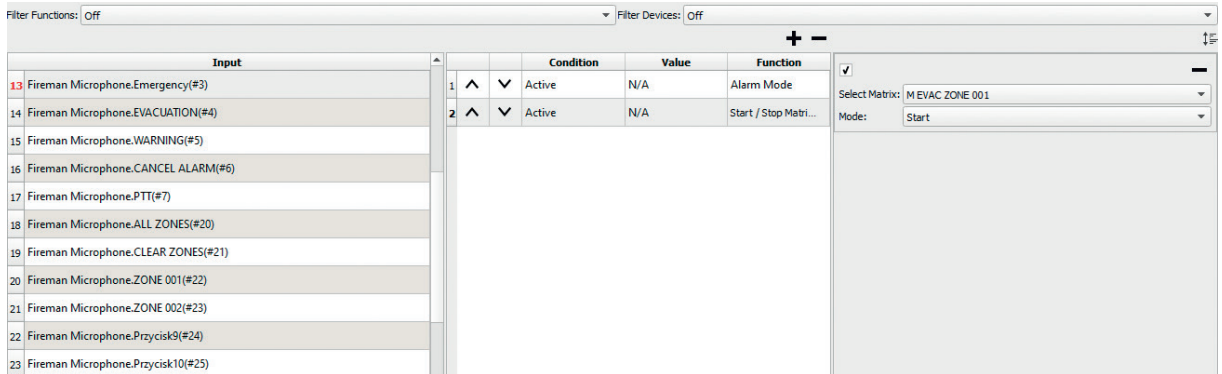
14. Program xLogIN card – logic inputs and buttons on the system microphones. Go to the [Event Configuration](#)  tab. Sample configuration by activation of button on the DFMS fireman microphone causes system entrance to the [Emergency](#) mode and activation of the evacuation matrix.



Input	Condition	Value	Function
13 Fireman Microphone.Emergency(#3)	1 ^ v Active	N/A	Alarm Mode
14 Fireman Microphone.EVACUATION(#4)	2 ^ v Active	N/A	Start / Stop Matri...
15 Fireman Microphone.WARNING(#5)			
16 Fireman Microphone.CANCEL ALARM(#6)			
17 Fireman Microphone.PTT(#7)			
18 Fireman Microphone.ALL ZONES(#20)			
19 Fireman Microphone.CLEAR ZONES(#21)			
20 Fireman Microphone.ZONE 001(#22)			
21 Fireman Microphone.ZONE 002(#23)			
22 Fireman Microphone.Przycisk9(#24)			
23 Fireman Microphone.Przycisk10(#25)			

15. Assignment of [Error signaling system](#) to active the relay output – program in the [Event Configuration](#)  tab. From the [Inputs](#) list select the [Error](#) function and assign the [General](#) function → [Add control output action](#) .

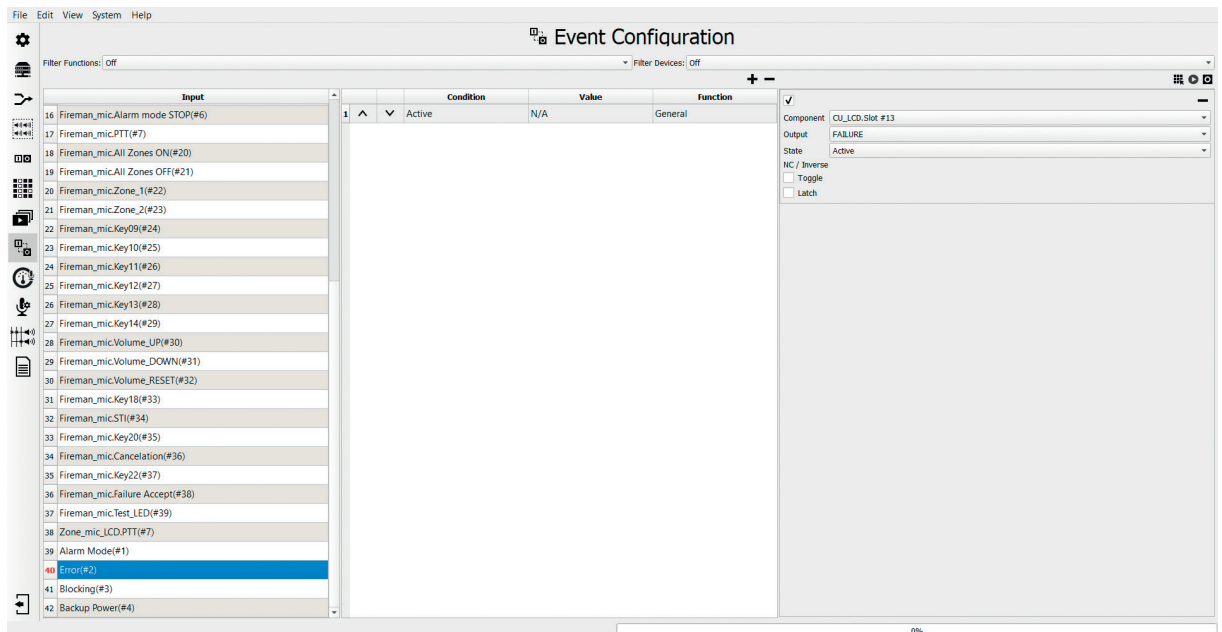

Input	Condition	Value	Function
16 Fireman_mic.Alarm mode STOP(#6)	1 ^ v Active	N/A	General
17 Fireman_mic.PTT(#7)			
18 Fireman_mic.All Zones ON(#20)			
19 Fireman_mic.All Zones Off(#21)			
20 Fireman_mic.Zone_1(#22)			
21 Fireman_mic.Zone_2(#23)			
22 Fireman_mic.Key09(#24)			
23 Fireman_mic.Key10(#25)			
24 Fireman_mic.Key11(#26)			
25 Fireman_mic.Key12(#27)			
26 Fireman_mic.Key13(#28)			
27 Fireman_mic.Key14(#29)			
28 Fireman_mic.Volume_UP(#30)			
29 Fireman_mic.Volume_DOWN(#31)			
30 Fireman_mic.Volume_RESET(#32)			
31 Fireman_mic.Key18(#33)			
32 Fireman_mic.ST1(#34)			
33 Fireman_mic.Key20(#35)			
34 Fireman_mic.Cancelation(#36)			
35 Fireman_mic.Key22(#37)			
36 Fireman_mic.Failure Accept(#38)			
37 Fireman_mic.Test_LED(#39)			
38 Zone_mic_LCD.PTT(#7)			
39 Alarm Mode(#1)			
40 Error(#2)			
41 Blocking(#3)			
42 Backup Power(#4)			

16. Send the configuration to the system by selecting [System](#) → [Connection settings](#) → [Upload configuration](#). The system is programmed when the [Server Status](#) displays the following information: [Downloaded – The same configuration](#).

13.14 Glossary

Function activating modes

Start – selected button or logical input only activates a function programmed in the system.

Stop – selected button or logical input only deactivates a function programmed in the system.

Toggle – selected button or logical input triggers, a change of state to the opposite upon every next activation, acting like an on/off switch. In case of logical inputs, a necessary condition for reactivation of the function in the toggle mode is returning to the input's idle state.

Dynamic assignment

In order to trigger a function whose activation relies on dynamic assignment, follow the predefined order. The first activity is selection of a zone or multiple zones by means of the programmed [Select Zone](#) button, in this way we highlight which zone(s) the function is to affect, then select the button assigned to the function which we want to execute.

Audio inputs – these are all analogue inputs available in the smartVES system to which external sound sources can be connected to.

Audio outputs – these are all outputs available in the smartVES system, whose parameters are compatible with the audio inputs of the amplifiers. Control units are equipped with audio outputs, e.g. SMART-CU-11 has 12 audio outputs, as well as zone microphones which are equipped with 4 outputs.

Audio source – in the smartVES system, an audio source is both a recorded message, regardless of its priority, a linear audio input on a unit and a zone microphone, as well as the microphone itself.

Individual HV Audio In – this is an input found on each xCtrLine-4 /xCtrLine-2 control card which is used to connect an amplifier 100 V output to the card. In this way the control card has a specific amplifier assigned to it and does not use in normal system operation (i.e. no damage to individual amplifier) the common 4 four 100 V buses available for all control cards in a given unit.

System states – there are 4 system states available in the configurator: [Alarm mode](#), [Error](#), [Blocking](#), [Backup Power](#) due to which any function can be activated or an element available in the system can be controled.

Go to Definition is a quick access function which is activated by clicking the left mouse button while moving over onto the name of any element in the system. This function results in a transition to the card, microphone, device microphone extension detailed editing window.

Configurator

Software supplied with the smartVES system with the help of which it is possible to manage and program system devices.

FIFO (First IN, First OUT) – in case of conflict of two audio sources of the same priority, where Source 1 is already transmitting to the zone and Source 2 is also to begin transmitting to the same zone, Source No 1 will not be removed in order to make the zone available for Source No 2 until Source No 1 (matrix) has concluded transmission.

LIFO (Last IN, First OUT) – in case of conflict of two audio sources of the same priority, where Source 1 is already transmitting to the zone and Source 2 is also to begin transmitting to the same zone, Source No 1 will be disconnected from the zone and Source No 2 will transmit to the zone.

LUA – scripting language used to extend the functionality of the smartVES system. This language is implemented as the C language library, written according to ANSI C, providing: simplicity, performance and code transferability.

Signalization priority

	PRIORYTET (0 – highest)
Block zone	0

Zone failure	
› closing / shorting / opening	
› no EOL	1
› impedance error	
› switching into LOOP	
.....	
Zone failure confirmed	1
EVACUATION MESSAGE playback	2
WARNING MESSAGE playback	2
Spoken message from fireman microphone	2
Spoken message from zone or BGM microphone	2
Volume change	3
Audio Monitor	4

13.15 FAQ

1. No smartVES server visible in the **System Connection** window

In order to upload the configuration to the system, download the reports from the system or go to online mode the configuration software must be combined with a server visible in the **Connection Setup** window (**System** → **Connection Settings**). If the server is invisible you should at first reassure that the static IP address is not set on the local LAN adapter of computer with smartVES Selector software. Check the card properties or Internet Protocol Version 4 (TCP / IPv4) if obtaining of an IP address is set automatically. Then, disable the Windows Firewall (Settings → Control Panel → System and Security → Windows Firewall – enable or disable the firewall). Turn off Windows Firewall for both the private and the public networks. If the server is still not visible in the **System Connection** window, make sure that the computer does not have security software installed. If so, choose Suspend protection option. In order to reactivate Windows system security it is recommended to add the connection to the smartVES server to the secure connection list.

Another reason for server invisibility in the connection window may be the encrypted connection used since firmware version 0.750.1:

- » attempting to connect Selector from version 0.750.1 to a system with a lower version
Read firmware version information from the LCD control unit in the “Interface Settings” section or connect to the system via Selector in lower version, read firmware version in connection window and continue working on dedicated version of Selector.
- » attempting to connect Selector below version 0.750.1 to a system with version from 0.750.1
Read firmware version information from the LCD control unit in the “Interface Settings” section and continue working on dedicated Selector version or connect to Selector in a version not lower than 0.750.1.

2. Configuration of the operating smartVES system cannot be downloaded

In order to download the correct configuration of the system:

1. Start the software smartVES Selector
2. Select **Create a new configuration** – **please note that it is a very important step!**
3. Connect to the server via **System** → **Connection Settings** and select the **Connect** button
4. Then in the same window choose the **Download current configuration** option

3. A downloaded configuration of the operating smartVES system cannot be opened

The downloaded file from the system, config.afz can be found in the tab Documents → Selector → Workspaces_x.x.x (where x indicates the version of the software) → downloadedConfiguration. To run the downloaded file from the system (*.afz) you need to:

1. Select in the configuration software: **File** → **Import working area**

2. As a standard, the configuration software creates files and saves them under: C:\Users\Documents\Selector\Workspaces_x.x.x \downloadedConfiguration. If you have chosen a different access path, please choose from it the appropriate file with the .afz extension and then select option [Open](#).
3. When you select [Open](#) option, the system asks for the indication of a new folder in order to copy the imported content from the system configuration. You should create a new folder, give it any name, select it and choose [Select Folder](#) option. **Please note that it is a very important step!**
4. Select [YES](#) option in the window if you want to open the imported configuration
5. The configuration will be loaded – in the [System connection](#) window with the [Connect](#) option, the [Same configuration status](#) should be shown. If [Different configuration](#) status is shown in the window, please select [File](#) -> [Load](#) -> the newly created folder while importing the file with the .afz extension. There are available the configuration.afz files in the location they were created when configuring the system. You have to load those files and then check the status until it shows the [Same configuration status](#).
6. If the Selector used is older than v0.750.1, the program will not see a system connection lower than v0.750.1 in the [System Connection](#) window. This rule also occurs when we try to use a lower version of the system with v0.750.1 software. This is due to differences in communication encryption.

4. The selected action cannot be completed - Selector indicates illegal characters in the names

When creating a new workspace or when unpacking from .afz file, you cannot use national special characters (e.g. ä , ö , ü) or any other special characters (e.g. !,@,#). The system will inform you about an invalid situation:

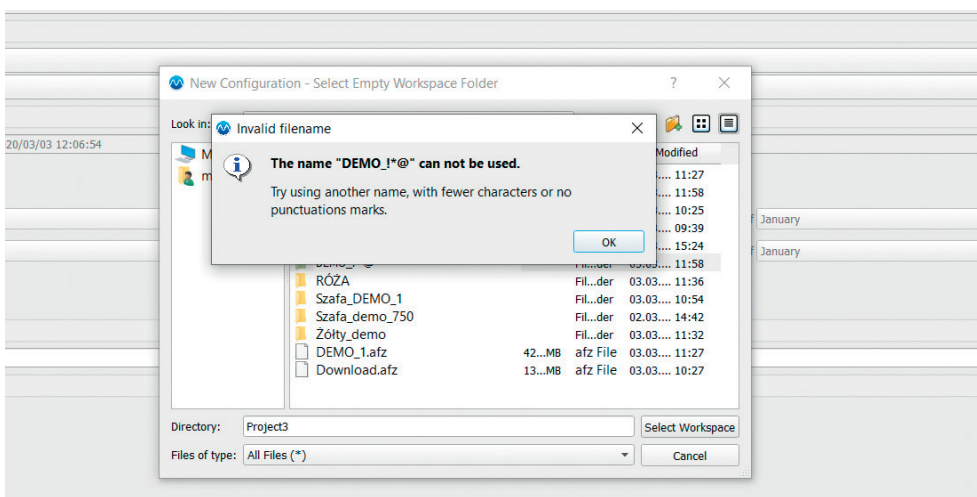

or

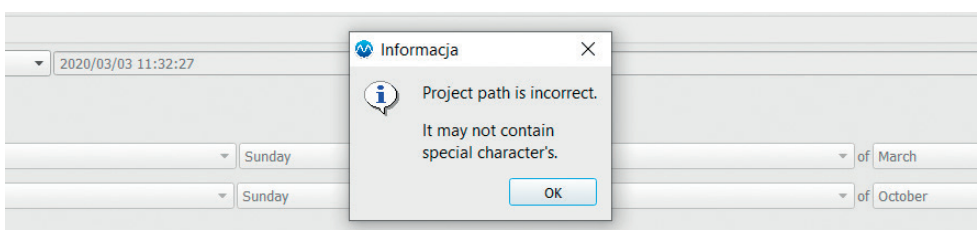

Particular attention should be paid to the names of HV Audio inputs and subzones in the control cards, the system will not allow you to enter a special character without any prompt.

In other places, such as device name or button description, special characters can be used.

5. DFMS, DMS or DMS-LCD microphone reboots when connected to the system

If to a properly functioning system you additionally connect a microphone, that resets after connection this means that the microphone does already have a preloaded configuration into the memory which is different from the configuration of the system. In this situation the factory (default) settings should be restored to the microphone and then the microphone should be reconnected.

6. The configuration software suspends while trying to compare the topology of the configuration created in offline mode

If the system cannot properly detect the devices available on the smartVES network and prevents assigning MAC addresses to the configuration items created in offline mode it means that the list of devices in the Working area is different from what is visible in the system. The solution to this is to create a new project, which does not include any devices in the Working area and then select an option [Play topology \(System -> Connection Settings\)](#). In this way you get to know the correct arrangement of the system devices in the Working area. The arrangement of devices in the Working area should be restored to its original configuration created in offline mode and then option [Play topology -> Compare](#) should be reselected. When there appears a table with all elements available in the system to assign addresses to devices Mac added Field work set together, please select the [Repair](#) button.

7. The system does not respond to command [Restore to Factory Defaults](#)

Each project possess its own unique [Factory Defaults](#) signature, which is available in the window: [Basic Configuration -> Factory Defaults](#). Every time you call the Default settings, the system checks the validity of the system signature with the one located in the configurator. Lack of compatibility will cause the command disregard.

8. How should I transfer a configuration that can be opened on another computer?

Full configuration means the device settings, source audio file, and summary of matrix, scenarios, zones etc. after conversion to pcm. It is written via [Export working area](#) function in the [File](#) tab.

9. After signal stenciling onto the selected zone the system reports an "E0209" error – "lack of measurement conditions"

Ensure that digital volume control regulators, available from the front panel system amplifiers are set within the -4 – 0 dB range. Setting values below -4 dB results in decrease of expected values of the testing pilot and declaration of system error "Lack of measurement conditions". It is suggested to check the settings of all channel amplifiers available in the system.

10. The system does not report any PSM power manager errors

If the system does not report any PSM device errors, make sure that PSM is properly connected to the ISLE module, and that ISLE module (island) is connected to RS485 port on control unit. In addition, check if under [Select PSM](#) option the number of connected power supply managers has been defined.

11. Short, unwanted, beeps are hearable in the speakers

Check through the Selector software and the sound card preview to see if the audio signal is switched from the audio path dedicated to the appropriate speaker line control card to the spare channel.

If so, check if the total power of the lines connected to the speaker line control card matches the power of the amplifier that supports it.

Otherwise, check if the problem only occurs with a specific audio solution, e.g. an external audio source and check the cable connections.

13.16 Appendix

1. AutoStandby mode

The purpose of the operation in [Standby](#) mode is:

- » limiting the power consumption from the battery while there is the loss of the primary power supply 230 V voltage;
- » reduction of heat energy generated by the amplifiers as far as control units while working on the primary power at any preset time, if the system does not have any active matrices – standby/idle mode.

Principle of operation [Standby](#)

[Standby](#) mode is activated automatically and every time when the following conditions are met simultaneously:

- » there has been a loss of primary power supply (230 V) and the system passed on battery power
or
- » system has no active audio matrices and operates in Normal mode (no Alarm).

While working in active [Standby](#) mode the smartVES system periodically changes its operating states on the following sample states:

- » *active_state*
- » *suspended_state*

Duty cycle of the above conditions is as follows:

- » *suspended_state* – 85 seconds
- » *active_state* – 5 seconds

Managing processor actions (e.g. the card processor) in [Standby](#) mode:

- » Periodically sends signals to the amplifiers indicating the current mode and operating state to enter amplifiers into power saving mode.
- » Periodically sends signals to all the control cards (xCtrl-2, xCtrl-4) informing cards about the current state of work (*active_state* / *suspended_state*) to force a power saving state to control cards (or exit from this state).
- » Each time while sending a command to change the state of the control card – it verifies whether the card has changed its state and if it properly reacts to read state.
- » Turning control and error reporting is done automatically after sending commands to change the status on *active_state* and confirmation from the card it has exited this mode.

Amplifiers actions in [Standby](#) mode:

- » During operation in the *suspended_state* amplifiers enter a reduced power mode (amplifiers stop working and do not consume energy or consume a minimum value of it).
- » During operation in the *active_state* amplifiers enter a reduced power mode so return to normal operation.

[Standby](#) mode is called using the [Standby](#) function.

- » That function can be activated by using:
 - › o timers (it can be called in a cyclic manner at any preset time);
 - › any logic inputs;
 - › programmable “Key” push buttons;
 - › automatic run in the absence of active matrices defined by the user time [min] [AutoStandby](#).
- » This function can be activated under the following conditions:
 - › system is not in alarm mode;
 - › there are no active audio matrices with [Emergency](#) / [Service](#) priority;
 - › system is powered from the primary source 230 VAC (while entering on battery power it happens automatically if the system is not in alarm mode and there is lack of active [Emergency](#) / [Service](#) matrices).

[AutoStandby](#) – the function is activated/deactivated by the user on the level of the configuring software in the form of a checkbox. The function is activated in the absence of active audio matrices of [Emergency](#) / [Service](#) priorities by the time defined in the Configurator.

The time is determined in minutes / The time interval [15 ... 300 minutes]

Default state – checkbox enclosed, active function

Default activation time: 60 minutes

[AutoStandby](#) function is available in the [Basic Configuration](#):



Each attempt of audio broadcasting while **Standby** is active causes:

- » exit from **Standby** to the **Normal** mode (when the power supply is basic), regardless on the priority of a message;
- » exit from **Standby** mode to the **BattMode** (when there is lack of primary power supply) only when messages will have **Service/Emergency** priority.

The maximum duration of the activation process of exit from **Standby** mode to broadcasting message is shorter than 500 ms.

Because the function has been implemented in Phase 1 of smartVES development and its activation is in a dynamic way ([Zone selection](#) then pressing [Power Save](#) button) there is need to change the way of its implementation from the dynamic to static (PA zones strictly defined in the configurator are to be deactivated / activated by friendly [Power Save](#) features.

Diagram of transition **Normal** mode – **Battery** mode – **Standby** mode is shown below:

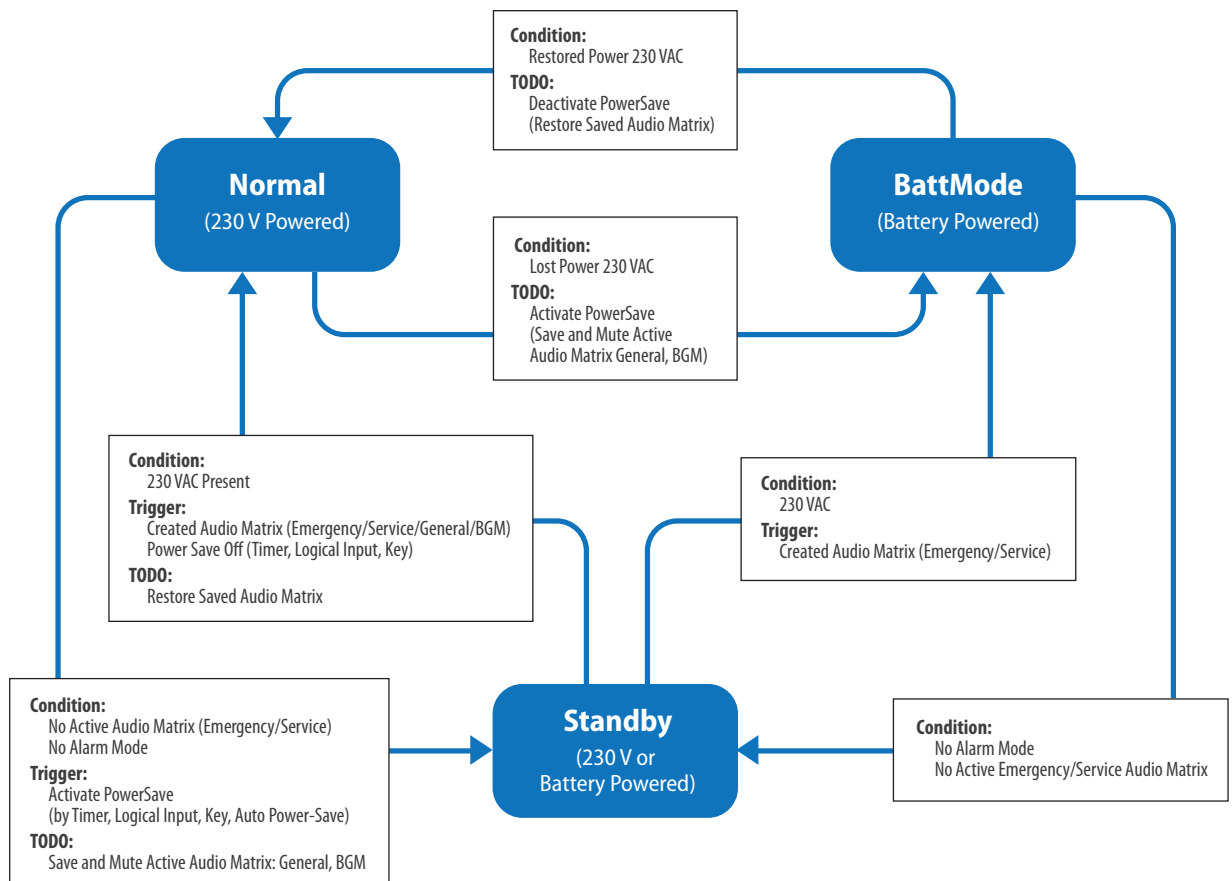

2. The list of errors reported by the system

E: Error – fault description visible on GUI of the control unit / **W: Warning** – access to this type of the information via Selector software – [System Report](#) only / **I: Info** – access to this type of the information via Selector software – [System Report](#) only.

“E0001” – “Function backplane power failure” – no 5 V in the functional part
“E0002” – “Function backplane power failure” – no 12 V in the functional part
“E0003” – “Function backplane power failure” – no -12 V in the functional part
“E0011” – “Control backplane power failure” – no 5 V control part
“E0012” – “Control backplane power failure” – no 12 V control part
“E0013” – “Control backplane power failure” – no -12 V control part
“E0022” – “Power control system failure” – damage control system control part
“E0023” – “Power control system failure” – damage control system functional part
“E0101” – “Device do not respond”
“E0102” – “Logical input open”
“E0103” – “Logical input short”
“E0104” – “Speaker line ground fault”
“E0105” – “Speaker line short”
“E0106” – “Files integrity error”
“E0107” – “Speaker line impedance error”
“E0108” – “Speaker line open”
“E0109” – “EOL error”
“E0110” – “Interruption of the audio path”
“E0111” – “Battery failure”
“E0112” – “Backup power / PSM missing”
“E0113” – “230V AC power failure”
“E0114” – “Amplifier overheat”
“E0115” – “Fuse failure”
“E0116” – “Power system manager failure”
“E0117” – “48 V DC error”
“E0118” – “No communication with ABT-ISLE”
“E0119” – “Loop link error”
„E0120” – “48V DC failure on port RS485”
„E0122” – “Optical link connection mismatch”
„E0130” – “FAN failure”
„E0131” – “Amplifier oveheat”
„E0132” – “Microphone failure”
„E0133” – “Temperature sensor failure”
„E0134” – “Supply failure”
„E0135” – “Battery voltage too low”
„E0136” – “No batt. or damaged fuse”
„E0137” – “No calibration data, CU001”
„E0138” – “Calibration data corrupted”
“E0200” – “ABT-DFMS missing”
“E0201” – “Evacuation button error”
“E0202” – “Backup audio path interruption”
“E0203” – “CPLD verification error”
“E0204” – “Interruption of the audio path in ABT-DFMS capsule”
“E0205” – “Internal hardware error”
“E0206” – “Error triggered from logical input”
“E0207” – “Integrity state error”
“E0208” – “Test generator failure”

"E0209" – "No conditions for measurement"
 „E0210" – "Incorrect number of extensions connected"
 "W0001" – "Function backplane power overload" – over current power supply 5 V functional part
 "W0002" – "Function backplane power overload" – over current power supply 12 V functional part
 "W0003" – "Function backplane power overload" – over current power supply -12 V functional part
 "W0011" – "Control backplane power overload" – over current power supply 5 V control part
 "W0012" – "Control backplane power overload" – over current power supply 12 V control part
 "W0013" – "Control backplane power overload" – over current power supply -12 V control part
 "W0021" – "Power supply overheat" – power supply overheat functional part
 "W0022" – "Power supply overheat" – power supply overheat control part
 "W0031" – "System operates on battery power"
 "W0101" – "Standby mode activation"
 "W0102" – "Standby mode deactivation"
 "W0103" – "Device Initialization error, dev=%x"
 "I0101" – "Alarm mode activation"
 "I0102" – "Alarm mode deactivation"
 "I0103" – "Event activation %xx"
 "I0104" – "Event deactivation %x"
 "I0105" – "Matrix activation %x"
 "I0106" – "Matrix deactivation %x"
 "I0107" – "Failure Accept"
 "I0108" – "Failure Delete"
 "I0109" – "Device start, dev=%x"
 "I0110" – "Connection state 0x%x->0x%x: %d"
 "I0111" – "Logical input 0x%x state changed %d"
 "I0112" – "Logical output (Relay) 0x%x state changed to the value %d"
 "I0119" – "Backup link activation"

Expanded error code 205 "Internal hardware error" list

An internal hardware error (E0205) is reported by the module when it diagnoses that one of its components is not working properly. Usually it concerns communication problems with elements connected to the I2C bus, but it can also indicate incorrect configuration or incorrect operation. In order to facilitate the diagnosis, a parameter was added to the error to determine which element is the problem. This parameter is a collection of flags.

Each flag is assigned to a specific item or erroneous state. The table below describes the meaning of each flag:

xCPU (ISA00003-02)

0x0001 no communication pca9548 (switch_i2c, bus 0, addr 0x70)
 0x0002 no communication pca9548 (switch_i2c, bus 1, addr 0x70)
 0x0004 no eeprom communication on backplane
 0x0008 no communication vcxo
 0x0010 no FPGA communication

cAudio-4/12 (ISA00005-01)

0x0001 no ADAU1701 communication (sigmaDSP,addr0x36)
 0x0002 no ADAU1701 communication (sigmaDSP, addr 0x34)
 0x0004 no communication ADAU1701 (sigmaDSP, addr 0x35)
 0x0008 no communication pca9548 (switch_i2c, 0x70)
 0x0010 no communication pca9548 (switch_i2c, 0x71)
 0x0020 no eeprom communication on backplane
 0x0040 no communication expander (16 channel IO, addr 0x20)
 0x0080 no communication expander (8 channel IO, addr 0x21)
 0x0100 no vcxo communication

xAudio-4/8—RS (ISA00004—01)

0x0001 no communication ADAU1701 (sigmaDSP)

xNET-1Gb/WAN / RS (ISA00001-02)

0x0001 no communication MCP3021AOT (ex_input, addr 0x48)

0x0002 no communication MCP3021AOT (ex_input, addr 0x4d)

DFMS (TA00003-01)

0x0001 no communication pca9555 (buttons)

0x0002 no communication MCP3021AOT (ex_input, addr 0x48)

0x0004 no communication MCP3021AST (ex_input, addr 0x4d)

0x0008 no communication cs4265 (codec)

0x001 0 no communication dac

0x0020 no pca9955 communication (led driver, addr, 0x61)

0x0040 no pca9955 communication (led driver, addr, 0x62)

0x0080 no communication max11601 (talk button, alarm button, potentiometer)

0x0100 no vcxo communication

0x0200 no communication pca9548 (switch_i2c)

0x0400 invalid state pca9955 (led fault)

Tables – damage to the guardless

smartVES – island (ISLE)

0x0001 blown fuse of the CH1 amplifier

0x0002 blown fuse on the CH2 amplifier

0x0004 blown fuse of the CH3 amplifier

0x0008 blown fuse of the CH4 amplifier

miniVES

Minives (xCharge)

0x0800 blown power supply fuse

0x1000 blown fuse of the CH1 or CH2 amplifier

0x2000 battery fuse blown

0x4000 blown fuse 48V (internal bus)

xCharge (BRD00012-01)

0x0001 invalid state BOARD_FFLAGO, TBD

0x0002 invalid state BOARD_FFLAG1, TBD

0x0004 invalid state BOARD_FFLAGZ, TBD

0x0008 invalid state BOARD_FFLAG3, TBD

0x0010 invalid state BOARD_FFLAG4, TBD

0x0020 invalid state BOARD_FFLAGS, TBD

xNET_M|N|—1Gb/WAN (BRD00010-01), xNET_M|N|—1Gb/WAN /RS (BRD0001 1-01)

0x0001 no communication PCA6416 (io_exp)

0x0002 no communication PCA6408 (io_exp ctrl)

0x0004 no communication PCA9548 (switch_iZc)

0x0008 no communication PCA9546 (switch_i2c ctrl)

0x0010 no communication AT24C02 (backplane eeprom)

0x0020 no communication PCA6416 (keypad io_exp)

0x0040 no communication MAX11601 (keypad adc)

0x0080 no communication MCP4651 (pa_potch1)

0x0100 no communication MCP4651 (pa_pot ch2)

0x0200 no communication PCF2129 (RTC charger)

0x0400 no communication PCA6416 (dip_sw)

0x0800 no communication CDCE913 (vcxo)

0x1000 no communication MCP4725 (vcxo_dac)

0x2000 no communication ADAU1701 (sigmaDSP)

3. The size of memory card in the control unit compared to available length of the message played, recorded and the number of entries in reports

SD Card [MB]	512	1024	2048	4096	8192	16348	32768
Audio Message 16 bit / 48 kS/s	20 min	40 min	80 min	160 min	320 min	640 min	1280 min
Reports	100 k	200 k	400 k	800 k	1600 k	3200 k	64000 k
BlackBox	60 min	120 min	240 min	480 min	960 min	1920 min	3840 min
RecordMessage	20 min	40 min	80 min	160 min	320 min	640 min	1280 min

4. Software compatibility

The official versions possess three identification characters:

x.y.z

For the official version it is acceptable (but not preferred) to have four-character marking, but in this situation the last character always has to be zero "0":

x.y.z.0

Subsequent version numbers may only increase (in time), however increasing the number of the more significant character is always accompanied by resetting the less significant character.

The importance of the individual characters:

X (major number) – it is so called a major version. This number is changed only in special cases, while introducing major changes to the functioning and structure of the software.

It is forbidden to substitute software with any other numbering at major number. Such a change could mean eg. change of the operating system, framework, core libraries, and almost always results in a lack of compatibility backwards. Also, there is no guarantee of the correct functioning of the hardware. In particular, substitution of software – even if successful – can cause permanent damages to the device. There is also no guarantee of the proper functioning of equipment after returning to the previous version of the software. Replacement of the software in this case should always be consulted with the software provider.

Y (API number / feature) – this number is always increased at the time when differences at the *Application Programming Interface* level occur – that is, very often when adding new functionality to the officially released version. You may also have additional bug fixes – but this is not mandatory. Changing the number on the Y level due to other (e.g. new) functionality will usually mean the lack of full software compatibility, but does not exclude that the new functionality does not affect compatibility. Such a change should always ensure no damage to the equipment after replacing software. Information of software compatibility backward should always be provided during the official release.

Z (bug number) – number incremented always at the subsequent bug fixes. Compatibility of hardware and software backwards is guaranteed. There is no new functionality resulting in the lack of backward compatibility. This means that the FW/SW is fully compatible when X.Y are the same (except the ones with fixed errors or minor adjustments).

Note: due to the introduction of encrypted communication, from version 0.750.1 there is the following dependence:

- » systems with FW lower than 0.750.1 will not be visible in the System Connection window of the Selector in version higher or equal to 0.750.1
- » systems with FW 0.750.1 or higher will not be visible in the System Connection window of the Selector lower than 0.750.1

14. smartVES system touchscreen user manual

The following instructions describe the available functions and how to operate them from the touch screen located on the front panel of the SMART-CU-8LCD and SMART-CU-11LCD control units.

14.1 Home screen (screen saver)

Control units in idle status display the start screen (screen saver) informing about the system status, control unit name, current date and time in the system.

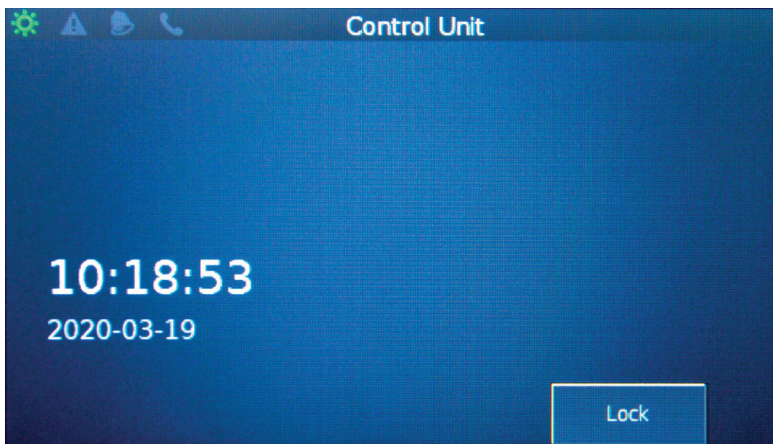

14.2 Lock screen

From the start screen (screen saver), we can use the **Lock** function, which allows you to set a password to access the screen. Touching the **Lock** icon displays an applet with which you can set a password consisting of one to six digits. The password has been confirmed with the **ENTER** icon.

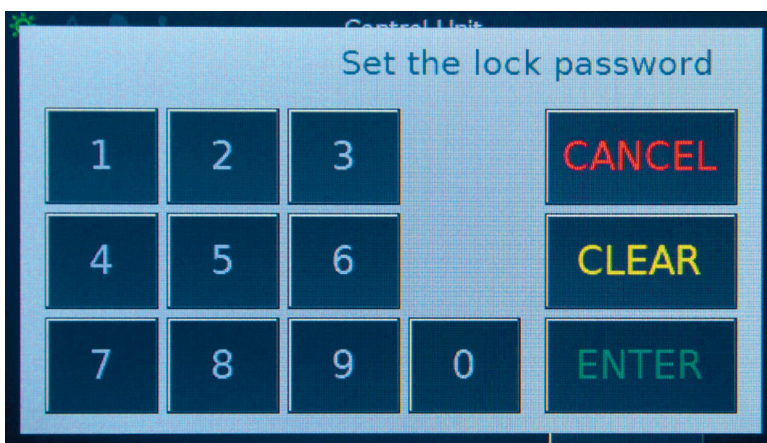

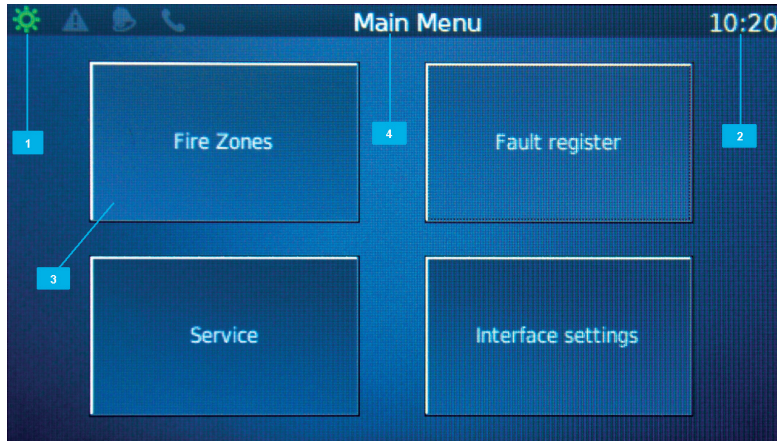

Once set, the lock password will be remembered by the system until you restore the factory settings from the Selector program.

14.3 System Options



1 System Status Icons

The top left field of the screen contains information about the current state of the smartVES system.

When only the green power icon  is displayed, it means that the system is in normal mode (no Alarm) and no faults have been detected. Changing to a blue icon  means the system is in standby mode.

The triangle icon with an exclamation mark  indicates that internal mechanisms monitoring the state of the system have detected damage. Fault details are available after selecting the [Fault register](#) icon.

A red bell icon  means that the system is in alarm mode and only audio signals with Evacuation priority can be active.



2 The field displays the time of the internal system clock

3 The four main icons are used to navigate between the various functions available from the screen

4 The name of the displayed window

14.4 Fire zones

The **Fire Zones** tab allows you to matrix an audio message / input to a selected zone or fire zones, as well as to view the status of a given zone: failure, blocks, playback with information as to which source.

Note – the up/down arrow markings  and return  are carried out using the physical buttons located on the right side of the screen, not the icons themselves.



To matrix an audio source for a selected zone/zone group:

1. Select the icon(s) with the name of the zone or select the **Select all** icon – when selected, the icon(s) will turn yellow.
2. Select the **Source** icon:
Select the available audio input from the list or switch via the Messages icon to available messages loaded into the system's memory – select from the list and then select the **Play** icon.

This will create the matrix and activate it – the selected audio source will be played in the selected zones.

To stop playing the selected audio source, select the source again and press the **Stop** icon.

Audio Inputs window

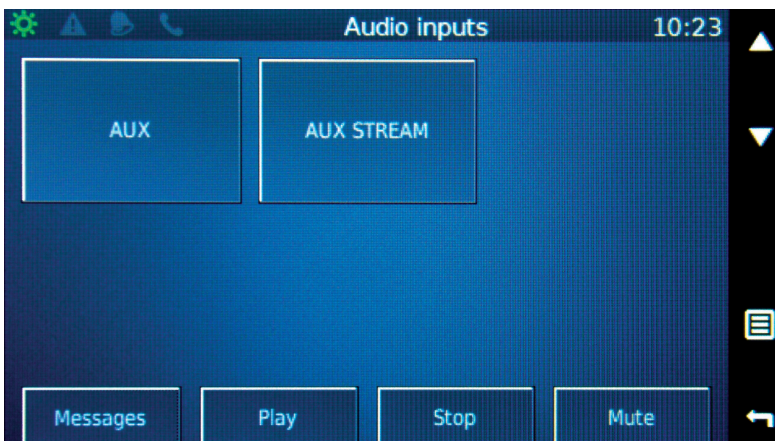

Message window



The **Mute** function is used to mute the audio source/message globally throughout the system. Select the source, the selected source will highlight in yellow and then select the **Mute** icon.

By clicking the back button located next to the icon  you will go to the main window **Fire Zones**, where we can verify if the zone selected by us plays the selected source (signaling within the zone icon).

Access to defined fire zone groups is displayed after selecting the **Group fire zones** icon from main menu **Fire Zones**.

In order to disable the zone (stop playing messages or audio inputs) or completely stop the possibility of playing any audio signal, select the zone/group (it will be highlighted in yellow) and then select the **Stop/Unblock**, which is located in the lower right corner of the **Fire Zones** screen. After selecting the appropriate option **Stop** or **Block/Unblock**, the function will be performed.

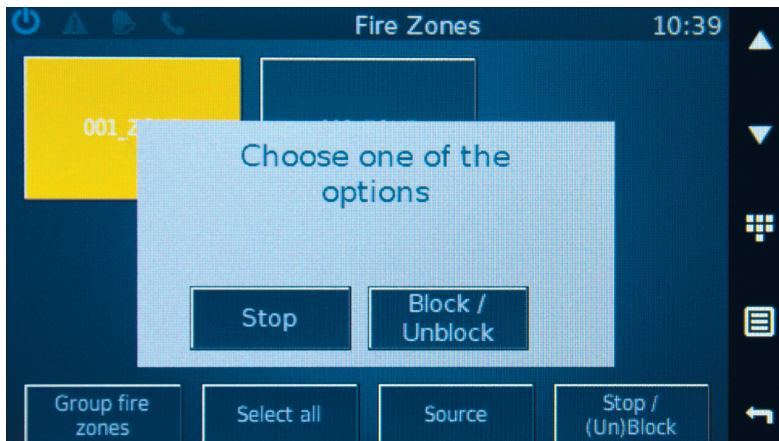

14.5 Numerical selection of fire zones

It is possible to select fire zones in the system using three-digit numbers.

To make this functionality active, you must give the zones names during the system configuration, including the three-digit prefix, according to the scheme XXX_zone name (e.g. 001_ZONE).



After opening the [Fire Zones](#) tab, use the button near this icon  to activate the numerical selection of the fire zone.

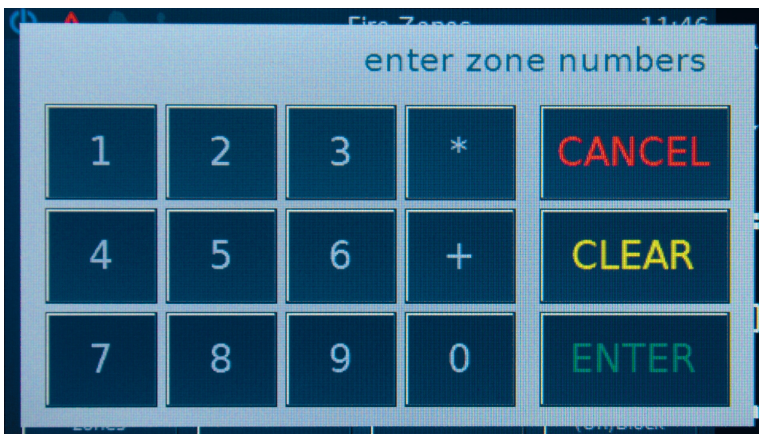

Enter the three-digit number of the fire zone and confirm with **ENTER** icon.

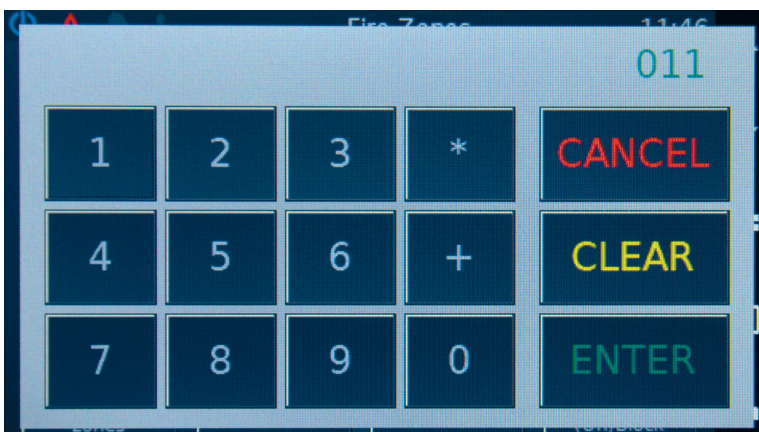

The fire zone we have chosen will be highlighted in yellow.



It is also possible to select several zones at the same time. To do this, enter the numbers of the selected zones, placing the + symbol between them.
 Example in the graphic below.

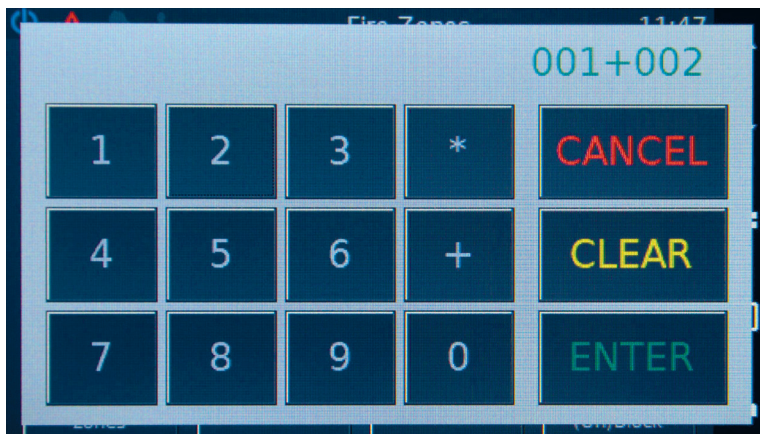

Operation is confirmed with the **ENTER** icon.

Another option for selecting fire zones allows you to select zones whose first elements of the name are common, e.g. all names starting with the syntax **01**. To do this, enter the syntax you want and add the symbol *****.

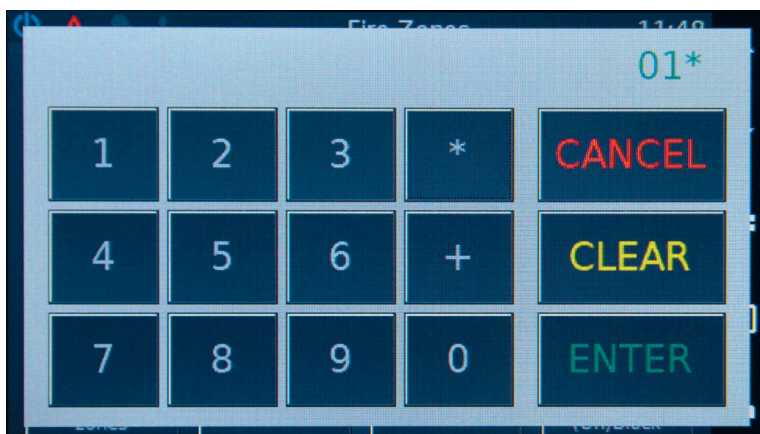

Operation is confirmed with the **ENTER** icon.

14.6 Fire zone groups



The **Group fire zone** icon allows you to open the screen with a view of the previously defined fire zone groups.

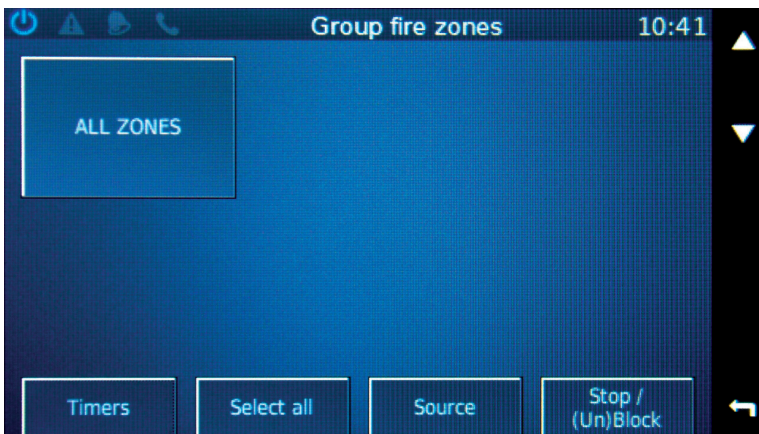

This tab allows you to perform the following actions:

- » check or uncheck a group of zones;
- » starting or stopping previously defined timers by selecting the timer (yellow color) and then using the **Start** or **Stop** icon; the timer status is signaled by a description within the timer icon;
- » select / deselect all fire zone groups (**Select all** icon).

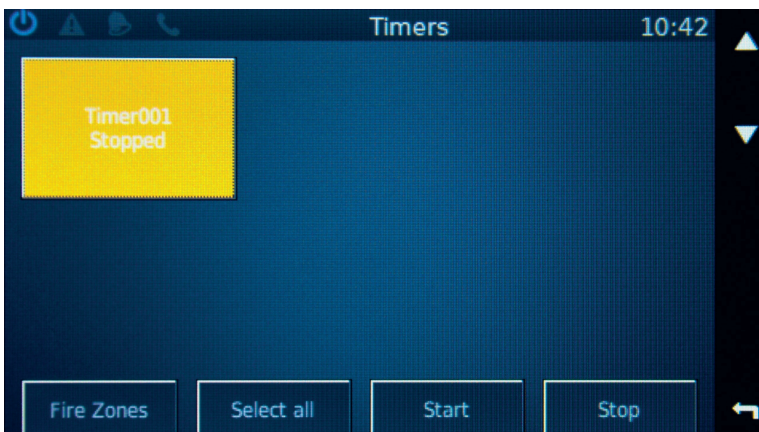

14.7 Service

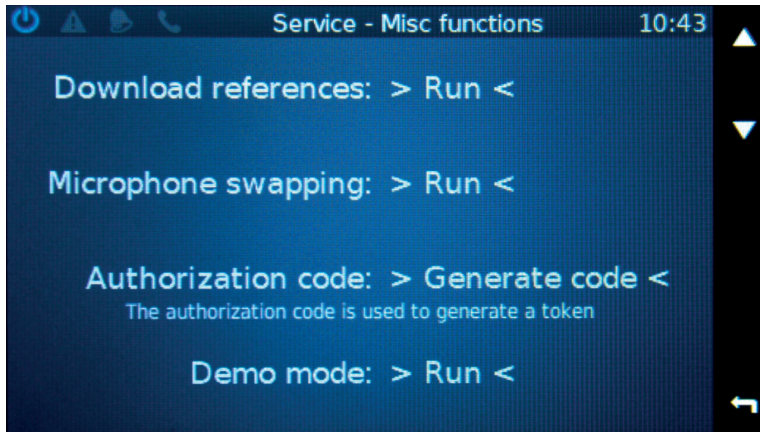

The **Service – Misc functions** tab provides access to the basic functionalities needed for servicing or starting the system. Allows you to view impedance on each line of the control card, save impedance reference globally (on all cards) or on the selected output. It is also possible to generate an authorization code, swap zone microphones and fireman microphones in the event of physical substitution of devices, and to launch demonstration mode.

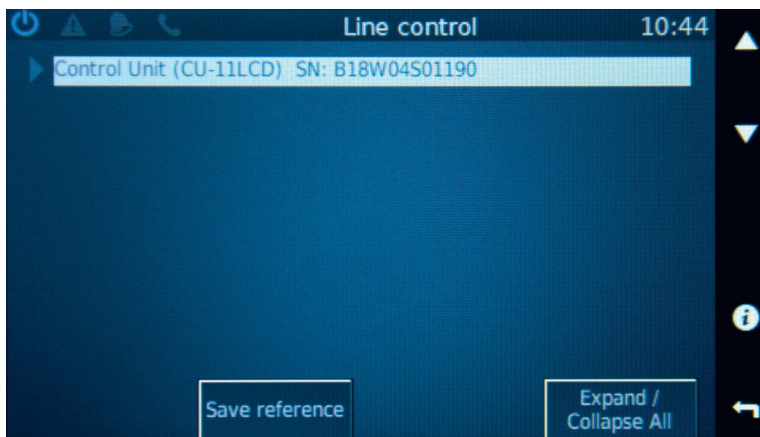

To download the impedance reference of the loudspeaker lines, select the **Run** field in the **Download reference** position:

In the **Line control** window, choice of control units with the buttons on the up / down . For initiate the process of downloading impedance reference values use **Save reference** icon.



To view the current impedance on the selected control card, select the control unit, use the  button, select the speaker line control card and use the  button again.

To save the impedance reference on the selected control card, use the buttons up / down  to select the control card and then use the icon **Save reference** – the impedance reference measured only on the speaker lines in the selected line control card will be saved.

The **Expand / Collapse All** icon displays the serial numbers of the speaker line control cards in all control units.

The **Microphone swapping** option is used to replace the configuration files of the zone microphones and the fireman in the case of substitution with a new one without configuration. In order to load the configuration into a new replacement microphone – e.g. a damaged one – select the **Run** field in to the **Microphone swapping** option. Then, using the up / down  icons select from the list of unavailable devices the microphone that has been removed from the system (List of mic. undetected), then select the **List of new mic.** icon and select a new microphone that is active but has no configuration. Individual serial number of the microphone is used for identification. To assign a configuration, select the **Pair microphone** icon.

List of undetected microphones in the system



List of new microphones but without configuration



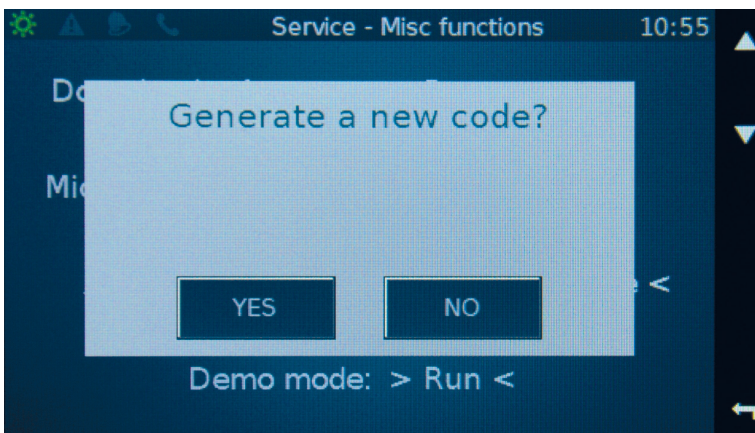

Code generation:





If the system configuration has been password protected and the password is unknown, there is a way to overwrite the old password by authorizing it in the configuration software using a token. After selecting the [Authorization code](#) option in the Service main menu, a 6-digit number will be displayed, which should be sent to Ambient System (support@ambientsystem.pl) to generate the authorization token.

Note: a request to generate an authorization token can only be sent by the system owner or manager or a person who obtains the written consent of the owner or manager and attaches it to an email.

From the Service window, use the buttons up/down  to go to additional functions available on the GUI:

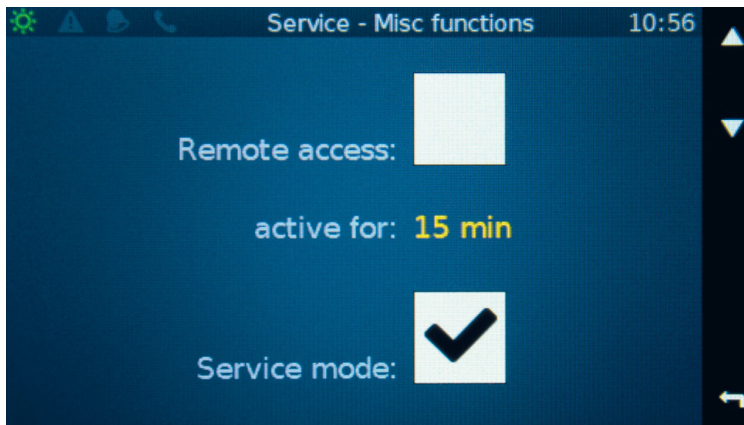
- » **Remote access.** It is an option that allows the system to connect to a remote server, where the simultaneous activation of remote access disconnects the local server enabling connection to a computer via Selector software. The connection time with the remote server is defined by clicking the time field and changing with the buttons up/down  in the range from 15 minutes to 3 days.
- » **Service mode.** Unchecking the service mode will restrict access to system functions. If the service mode is turned off, it is only possible to select zones and activate audio sources from the touch screen.



The service mode is reactivated after successive presses of four icons in the upper left corner of the display . It practically comes down to repeatedly sliding your finger on these icons until you see information about the activation of the service mode, which must be confirmed with the **OK** icon.

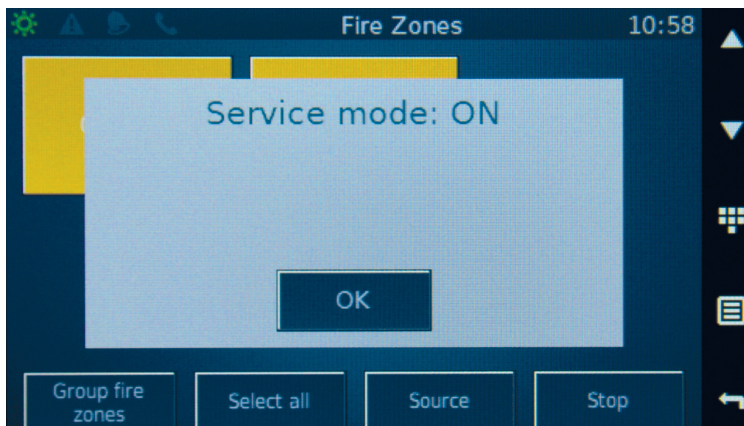

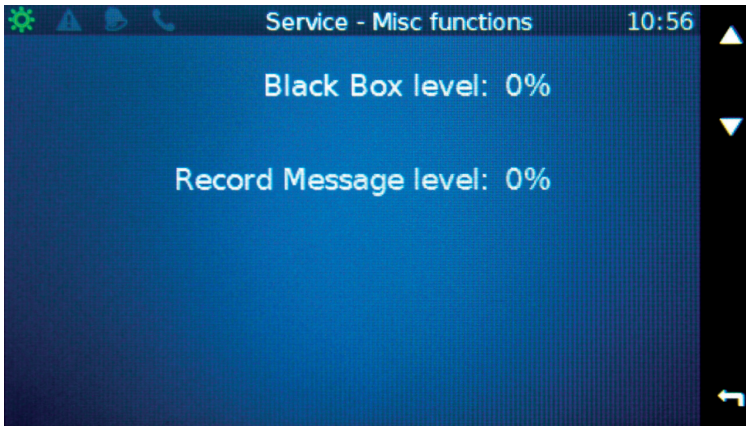

Selecting the "down" button again  will take you to the last tab showing the occupation of the Record Message and BlackBox buffers.



14.8 Fault register

The [Failure register](#) tab allows you to view the current damages detected by the system. The buttons located at the bottom of the screen allow viewing the failure history, sorting entries, confirming the fault (after confirming the fault acoustic signaling is turned off) and clearing the fault with calling the check function again.



Scroll the list of faults with the buttons up/down . The detailed description of the fault is displayed by pressing the information button . A detailed description of the information includes: notification number, error code, date and time of the fault occurrence, description of the fault and a detailed description of the device the fault relates to (control unit, card name, slot, line – assigned audio output).

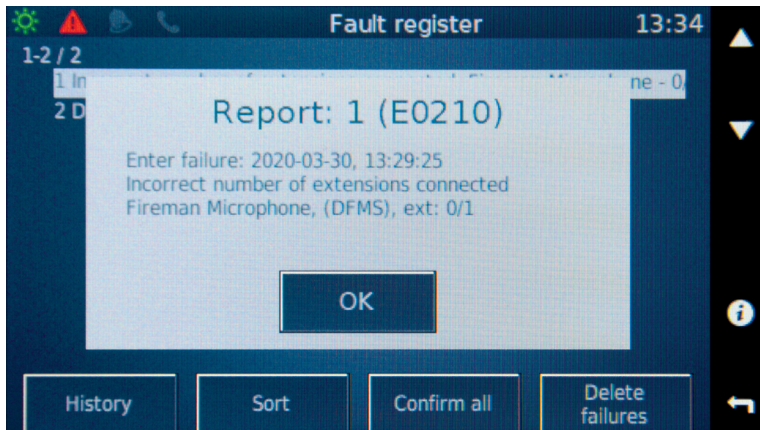

Selecting the [Sort](#) icon allows you to sort the damage list by date, module, unit, failure code.

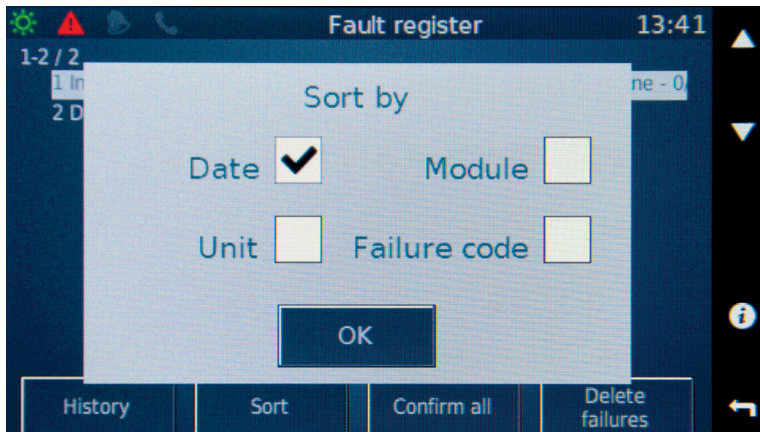

Selecting the [History](#) icon allows you to view past failures with the ability to view failure details, sort, filter by start date, and delete the registry.

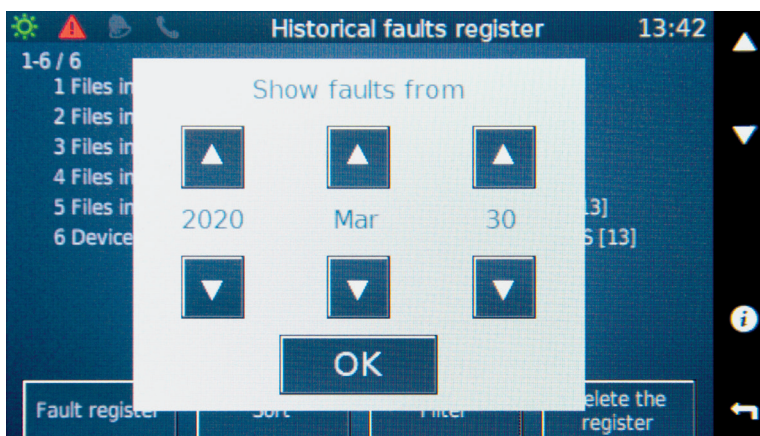

Selecting the [Delete the register](#) icon clears all entries in the failure history. Deleting the history log has no effect on the system event log, available through the Selector program.

14.9 Interface setting

The [Interface settings](#) window is used to set the language in which the display is operated, change the time zone and display information about the expected IP address of the remote server, the signature of the system firmware version along with the project name.

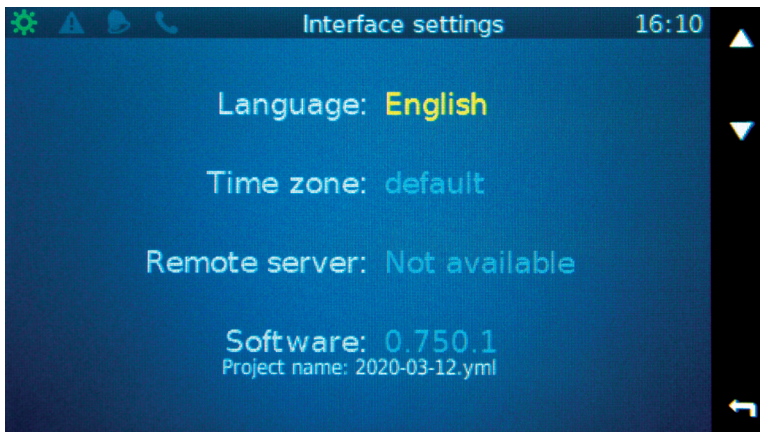

Screen timeout

Use the buttons up/down  to access the window activating the transition of the display to the energy saving mode. This function is natively active. It will cause that after 5 minutes from the last activity, the display will switch to the time and date view and after another 30 seconds, it will be completely blank.

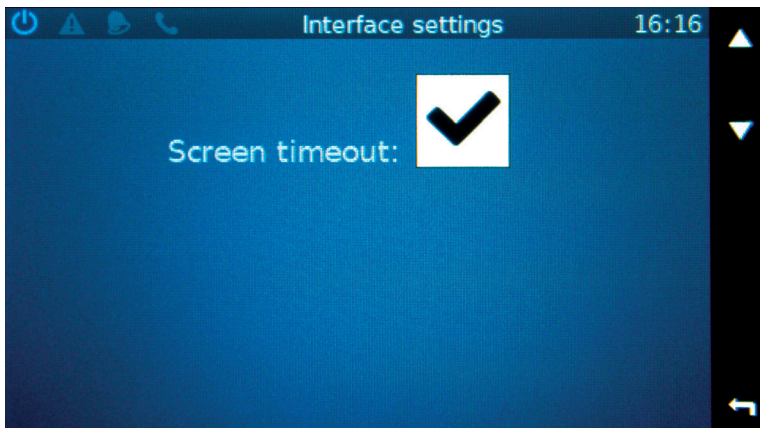

15. Annexes

- » List of certified switches to connect devices in daisy chain topology

16. Certificates

17. Glossary

AFL

Ambient Flex Language – internal script language based on LUA language. LUA is covered by X11 license.

AVB

Audio Video Bridging – technology of sending audio and video streams a computer network.

FACIE

Fire Alarm Control and Indicating Equipment – central part of fire signaling system powering fire detectors and receiving fire detection signals in order to trigger the alarm.

VASCU

Voice Alarm System Central Unit – central unit managing the voice alarm system.

TDM

Time-division multiplexing – method of realizing two or more communication channels in one transmission medium. Multiplexing allows limiting the number of transmission mediums.

18. List of tables

Table 1.	SMART-CU-8LCD technical data	23
Table 2.	SMART-CU-11LT technical data	26
Table 3.	SMART-CU-11LCD technical data	31
Table 4.	ABT-xCPU technical data	39
Table 5.	ABT-xNET-1Gb/WAN/RS technical data	41
Table 6.	ABT-xLogIN-8f/c technical data	44
Table 7.	ABT-xLogOUT-8f/c technical data	46
Table 8.	ABT-xAudIO-4/8-RS technical data	49
Table 9.	ABT-xAudi-8 technical data	50
Table 10.	ABT-xCtrLine-4 technical data	52
Table 11.	ABT-xCtrLine-2 technical data	54
Table 12.	SMART-xCtrLine-44 technical data	57
Table 13.	SMART-PA8080 technical data	64
Table 14.	SMART-PA8160 amplifier parameters	65
Table 15.	SMART-PA2650 technical data	66
Table 16.	Technical specifications of the SMART-PSM48 power supply manager	77
Table 17.	SMART-PS48800 technical data	81
Table 18.	ABT-DFMS fireman's microphone technical data	84
Table 19.	ABT-DMS zone microphone technical data	88
Table 20.	ABT-DMS-LCD technical data	91
Table 21.	ABT-EKB-20M technical data	92
Table 22.	ABT-NSC6 technical data	97
Table 23.	ABT-EOL technical data	98
Table 25.	LED colors of the button assigned to the function Select Zone	127
Table 26.	Color of the LEDs on the front panel of the control unit	128

19. List of drawings

Drawing 1.	SMART-CU-8LCD front panel	24
Drawing 2.	SMART-CU-8LCD rear panel	25
Drawing 3.	SMART-CU-11LT front panel	28
Drawing 4.	SMART-CU-11LT rear panel	28
Drawing 5.	SMART-CU-11LT rear panel – example layout of extension cards	29
Drawing 6.	SMART-CU-11LCD dedicated communication and audio card diagram	30
Drawing 7.	SMART-CU-11LCD front panel	32
Drawing 8.	SMART-CU-11LCD rear panel	33
Drawing 9.	SMART-CU-11LCD – example layout of extension cards	33
Drawing 10.	SMART-DU-1604 front panel	34
Drawing 11.	SMART-DU-1604 rear panel	34
Drawing 12.	Housing and interior of the SMART-AMAP-6 measurement microphone hub	36
Drawing 13.	SMART-ANSM-01 measurement microphone	38
Drawing 14.	ABT-xCPU processor card	39
Drawing 15.	ABT-xCPU processor card	39
Drawing 16.	ABT-xNET-1Gb/WAN/RS communication card	40
Drawing 17.	ABT-xNET-1Gb/WAN/RS communication card	41
Drawing 18.	Logical inputs/outputs diagram	41
Drawing 19.	Logical input card for function slot	43
Drawing 20.	ABT-xLogIN-8f front panel	43
Drawing 21.	Resistor wiring example on a monitored line	44
Drawing 22.	Logical input card for control slot	45
Drawing 23.	ABT-xLogIN-8 - front panel	45
Drawing 24.	ABT-xLogOUT-8f front panel	45
Drawing 25.	Logical input card for function slot	46
Drawing 26.	Logical input card for control slot	47
Drawing 27.	ABT-xLogOUT-8c front panel	47
Drawing 28.	ABT-xAUDIO-4/8-RS card	48
Drawing 29.	8 audio input card	50
Drawing 30.	ABT-xAudi-8 front panel	50
Drawing 31.	ABT-xCtrLine-4 loudspeaker lines control card	51
Drawing 33.	ABT-xCtrLine-2 loudspeaker lines control card	53
Drawing 34.	ABT-xCtrLine-2 front panel	53
Drawing 35.	Normal connection (impedance measurement)	55
Drawing 36.	Loop connection	55
Drawing 37.	SMART-xCtrLine-44 speaker line control card	56
Drawing 38.	SMART-xCtrLine-44 front panel	56

Drawing 39.	SMART-PAxxxx front panel	58
Drawing 40.	Front panel buttons	58
Drawing 41.	Block diagram of the menu structure of the amplifier	59
Drawing 42.	SMART-PAxxxx rear panel	60
Drawing 43.	8P8C connector (RJ-45)	61
Drawing 44.	Bridging of channel 1 & 2 outputs (100 V line)	62
Drawing 45.	Bridging two amplifier channels	63
Drawing 46.	48 V DC supply and ground connectors	63
Drawing 47.	ABT-ISLE	68
Drawing 48.	ABT-ISLE connectors diagram	68
Drawing 49.	Connection of power supply modules to the power manager	71
Drawing 50.	Connection of the battery pack to the power manager	72
Drawing 51.	Connection of CTRL LINK SMART-PSM48 with smartVES control unit via audio/RS interface ABT-ISLE	73
Drawing 52.	SMART-PSM48 power supply manager front panel	73
Drawing 53.	Front panel buttons	74
Drawing 54.	Block diagram of the power manager menu structure	75
Drawing 55.	SMART-PSM48/E power supply manager rear panel	76
Drawing 56.	CTRL LINK connector wiring	76
Drawing 57.	230 V AC power supply terminals and earth terminal	79
Drawing 58.	Rear panel of the SMART-PS48800 power supply unit	80
Drawing 59.	SMART-PF4 power supply frame	81
Drawing 60.	Microphone plug pin diagram	82
Drawing 61.	ABT-DFMS fireman's microphone	83
Drawing 62.	ABT-DFMS top panel	84
Drawing 63.	ABT-DMS zone microphone	87
Drawing 64.	ABT-DMS top panel	87
Drawing 65.	ABT-DMS-LCD zone microphone with display	90
Drawing 66.	ABT-DMS-LCD top panel	90
Drawing 67.	ABT-EKB-20M microphone keyboard extension	92
Drawing 68.	Connection of microphone and extension using aluminium connector	96
Drawing 69.	ABT-NSC6 noise sensing controller	96
Drawing 70.	ABT-EOL end-of-line supervision module	98
Drawing 71.	General connection diagram	100
Drawing 72.	Example of connection of control units in daisy chain topology	103
Drawing 73.	Connection of control units in Ring topology (optical fibre)	104
Drawing 74.	Individual connection of amplifiers to the SMART-CU-8LCD unit	105
Drawing 75.	Individual connection of amplifiers with SMART-11LT / SMART-11LCD unit	106
Drawing 76.	Connection with redundant amplifier channels to the SMART-CU-8LCD unit	107
Drawing 77.	Connection with redundant amplifier channels to the SMART-CU-11LT / SMART-CU-11LCD unit	108
Drawing 78.	Connecting a backup amplifier to the SMART-CU-8LCD unit	109

Drawing 79.	Connection of a backup amplifier to the SMART-CU-11LT / SMART-CU-11LCD unit	110
Drawing 80.	Power supply diagram	111
Drawing 81.	Preparing the cable termination	112
Drawing 82.	Completely open terminal of the Power Supply Manager	113
Drawing 83.	Proper cable position	113
Drawing 84.	Correct connection of storage battery cables	114
Drawing 85.	Interconnection diagram for 4x12 V DC VRLA batteries	115
Drawing 86.	Connecting the battery bank to the power manager	115
Drawing 87.	Ring-type optical fibre connection for firefighter's microphone	116
Drawing 88.	Fireman's microphone cable connection - daisy chain topology	117
Drawing 90.	Power supply for the fireman's microphone - LAN PoE	118
Drawing 91.	Power supply for the fireman's microphone - power output	118
Drawing 93.	Zone microphone connection	119
Drawing 94.	Connection between zone microphone and fireman's microphone	119
Drawing 95.	Zone microphone - switch connection	120
Drawing 96.	Zone microphone connection - switch (connected to SMART-CU-8LCD front panel)	121
Drawing 97.	Power supply for zone microphone - LAN PoE	122
Drawing 98.	Zone microphone power supply - power supply output of the control unit	122
Drawing 99.	Zone microphone power supply - power supply manager output	123



We make everyday life safer

Ambient System Sp. z o.o.

ul. Bysewska 27 | 80-298 Gdańsk

T: +48 58 345 51 95 | ambient@ambientsystem.pl