



miniVES



midiVES

Compact Voice Alarm System

EN

User Manual

EN 54-16:2008

EN 54-4:1997+AC:1999+A1:2002+A2:2006



ver. 11.2023

Table of Contents

1. Safety	3
2. miniVES and midiVES front panel	7
2.1 miniVES front panel	7
2.2 midiVES front panel	8
2.3 LED colors on the control unit front panel	8
3. miniVES and midiVES connector panel	10
3.1 miniVES L series and midiVES 8003R connector panel	12
3.2 miniVES LN, midiVES 8003 LN and 8003 LNR series connector panel	13
4. miniVES Charger	14
4.1 miniVES Charger	14
4.2 Batteries	16
5. Instructions for performing basic functions	17
5.1 Alarm mode	17
5.2 Failure mode	18
6. Technical data	19
6.1 miniVES 2001L, 4001L, 4002L	19
6.2 midiVES 8003R	22
6.3 midiVES 8003LNR , 8003LN	24
7. Mounting instructions	26
8. Notes	30

1. Safety



Danger!

High risk: This symbol indicates an imminently hazardous situation such as "Dangerous Voltage" inside the product. If not avoided, this will result in an electrical shock, serious bodily injury, or death.



Warning!

Medium risk: Indicates a potentially hazardous situation. If not avoided, this could result in minor or moderate bodily injury.



Caution!

Low risk: Indicates a potentially hazardous situation. If not avoided, this could result in property damage or risk of damage to the unit.

- 1 **Read these instructions.** All the safety and operating instructions should be read before the apparatus or system is operated.
- 2 **Keep these instructions.** The important safety instructions and operating instructions should be retained for future reference.
- 3 **Heed all warnings.** All warnings on the apparatus and in the operating instructions should be adhered to.
- 4 **Follow all instructions.** All instructions for installation or use/operating should be followed.
- 5 **Do not use this apparatus near water.** Do not use this apparatus near water or a moist environment – for example, near a bath tub, wash bowl, kitchen sink, or laundry tub, in a wet basement, near a swimming pool, in an unprotected outdoor installation, or any area which is classified as a wet location.
- 6 **Clean only with dry cloth.** Unplug the apparatus from the outlet before cleaning. Do not use liquid cleaners or aerosol cleaners.
- 7 **Do not block any ventilation openings. Install in accordance with the manufacturer's instructions.** Openings in the enclosure, if any, are provided for ventilation and to ensure reliable operation of the apparatus and to protect it from overheating. These openings must not be blocked or covered. This apparatus should not be placed in a built-in installation unless proper ventilation is provided or the manufacturer's instructions have been adhered to.

- 8 **Do not install near any heat sources such as radiators, heat registers, stoves, or other apparatus (including amplifiers) that produce heat or in direct sunlight.**
- 9 **No naked flame sources, such as lighted candles, should be placed on the apparatus.**
- 10 **Do not defeat the safety purpose of the polarized or ground-type plug.** A polarized plug has two blades with one wider than the other. A grounding type plug has two blades and a third grounding prong. The wider blade or the third prong are provided for your safety. If the provided plug does not fit into your outlet, consult an electrician for replacement of the obsolete outlet.
- 11 **Protect the power cord from being walked on or pinched particularly at plug, convenience receptacles, and the point where they exit from the apparatus.**
- 12 **Only use attachments/accessories specified by the manufacturer.** Any mounting of the apparatus should follow the manufacturer's instructions, and should use a mounting accessory recommended by the manufacturer.
- 13 **Use only with the cart, stand, tripod, bracket or table specified by the manufacturer, or sold with the apparatus.** When a cart is used, use caution when moving the cart/apparatus combination to avoid injury from tip-over. Quick stops, excessive force, and uneven surfaces may cause the appliance and cart combination to overturn.
- 14 **Unplug this apparatus during lightning storms or when unused for long periods of time.** Not applicable when special functions are to be maintained, such as evacuation systems.
- 15 **Refer all servicing to qualified service personnel.** Servicing is required when the apparatus has been damaged in any way, such as power-supply cord or plug is damaged, liquid has been spilled or objects have fallen into the apparatus, the apparatus has been exposed to rain or moisture, does not operate normally, or has been dropped.
- 16 **Avoid mechanical shocks.** Strong impacts and shocks may damage the device. Transport the device carefully and avoid dropping it.
- 17 **The apparatus shall not be exposed to dripping or splashing and that no objects filled with liquid, such as vases, shall be placed on the apparatus.**
- 18 **Batteries (battery pack or batteries installed) shall not be exposed to excessive heat such as sunshine, fire or the like.**
 **Caution!** Danger of explosion if battery is incorrectly replaced. Replace only with the same or equivalent type. Dispose of used batteries according to the environmental law and procedures.
- 19 **Professional installation only.** Do not use this equipment in residential applications.
- 20 **Condensation.** In order to avoid condensation; wait a few hours before turning on the equipment when it is transported from a cold to a warm space.
- 21 **Hearing damage.** For apparatus with audio output, to prevent possible hearing damage, do not listen at high volume levels for long periods.

- 22 **Do not disassemble the device or attempt to repair or modify it.** The device does not include user replaceable components inside the chassis. Opening the chassis and unauthorized repairs will void the warranty. Unauthorized substitutions may result in fire, electric shock or other hazards.
- 23 **Safety check.** Upon completion of any service or repairs to this apparatus, ask the service technician to perform safety checks to determine that the apparatus is in proper operating condition.



Danger!

Overloading – do not overload outlets and extension cords as this can result in a risk of fire or electric shock.

- 24 **Power sources.** This apparatus should be operated only from the type of power source indicated on the marking label. If you are not sure of the type of power supply you plan to use, consult your appliance dealer or local power company. For apparatuses intended to operate from battery power, or other sources, refer to the operating instructions.
- 25 **Power lines.** An outdoor system should not be located in the vicinity of overhead power lines or other electric light or power circuits, or where it can fall into such power lines or circuits. When installing an outdoor system, extreme care should be taken to keep from touching such power lines or circuits, as contact with them might be fatal.



Danger! Object and Liquid entry – never push objects of any kind into this apparatus through openings as they may touch dangerous voltage points or short-out parts that could result in a fire or electric shock. Never spill liquid of any kind on the apparatus.

- 26 **Protective grounding.** An apparatus with class I construction shall be connected to a power outlet socket with a protective grounding connection.

Protective earthing. An apparatus with class I construction shall be connected to a mains socket outlet with a protective earthing connection.

Note for power connections

- » For permanently connected equipment, a readily operable mains plug or all-pole mains switch shall be external to the equipment and in accordance with all applicable installation rules.
 - » For pluggable equipment, the socket-outlet shall be installed near the equipment and shall be easily accessible.
-



This label may appear on the bottom of the apparatus due to space limitations.



Caution! To reduce the risk of electrical shock, DO NOT open covers. Refer servicing to qualified service personnel only.



Warning! To prevent fire or shock hazard, do not expose units to rain or moisture.



Warning! Installation should be performed by qualified service personnel only in accordance with the National Electrical Code or applicable local codes.



Warning! Power disconnect: If the apparatus is mains powered and a power supply cord set is provided, the disconnect device is the mains plug of the power cord set. If an AC DC adapter is provided and the mains plug that is part of the direct plug in device, the AC DC adapter is the disconnect device. The socket outlet shall be near the apparatus and shall be easily accessible.



Old electrical and electronic appliances

Electrical or electronic devices that are no longer serviceable must be collected separately and sent for environmentally compatible recycling (in accordance with the European Waste Electrical and Electronic Equipment Directive). To dispose of old electrical or electronic devices, you should use the return and collection systems put in place in the country concerned.



Only used at altitude not exceeding 2000 m.



Only used in non-tropical climate regions.

2. miniVES and midiVES front panel

2.1 Front panel

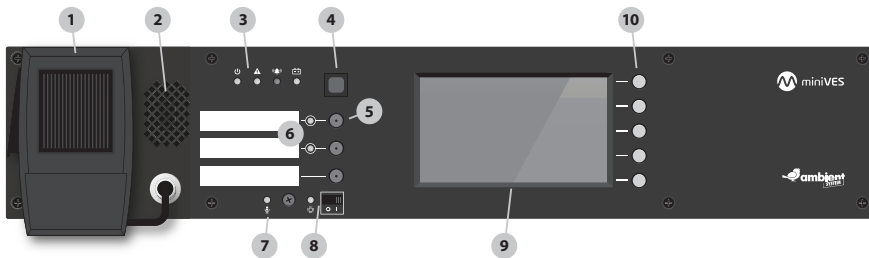

Fig. 1. Front panel of miniVES 2001L, 4001L, 4002L, 2001LN, 4001LN, 4002LN, 4002LNR series and midiVES 8003LN, 8003LNR

1. **Handheld fireman's microphone**
2. **Built in speaker**
3. **Indicators**
 - a. Power supply indicator (green LED)
 - b. Failure indicator (yellow LED)
 - c. Emergency indicator (red LED)
 - d. Battery failure indicator (yellow LED)
4. **Emergency button**
5. **Configurable function buttons**
6. **Function button activation LEDs**
7. **Handheld microphone LED**
8. **CPU off section**
 - a. CPU off function LED (yellow)
 - b. CPU off function switch
9. **Display – shows control unit's menu**
10. **Functional keys, support auxiliary functions when navigating the menu**
 - a. HOME – press to return to the fers menu
 - b. ENTER – press to enter value / select control unit in menu
 - c. Up arrow – press to navigate in the control unit menu
 - d. Down arrow – press to navigate in the control unit menu
 - e. Back – press to return to previous item in the control unit menu

2.2 Front panel of midiVES 8003R

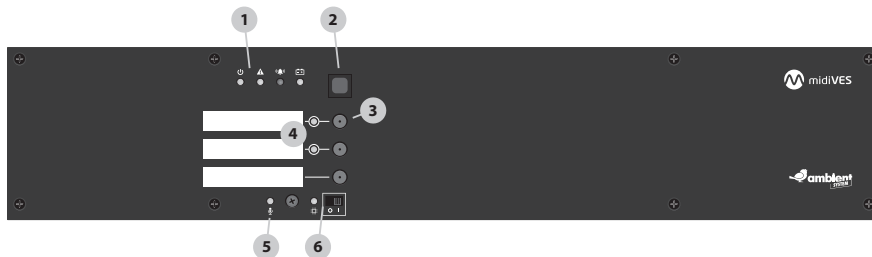















Fig. 2. Front panel of midiVES 8003R

1. **Indicators**
 - a. Power supply indicator (green LED)
 - b. Failure indicator (yellow LED)
 - c. Emergency indicator (red LED)
 - d. Battery power indicator (yellow LED)
2. **Emergency button**
3. **Configurable function buttons**
4. **Function button activation LEDs**
5. **Handheld microphone LED**
6. **CPU off section**
 - a. CPU off function LED (yellow)
 - b. CPU off function switch

2.3 LED colors on the control unit front panel

Graphic symbol	Color		miniVES, midiVES Control Units
		green	POWER
		yellow	FAILURE
		red	Blocking function active
		red	ALARM
		yellow	Battery failure
		green	Handheld microphone active
		yellow	CPU-off function active (CPU bypass)

3. miniVES and midiVES connector panel

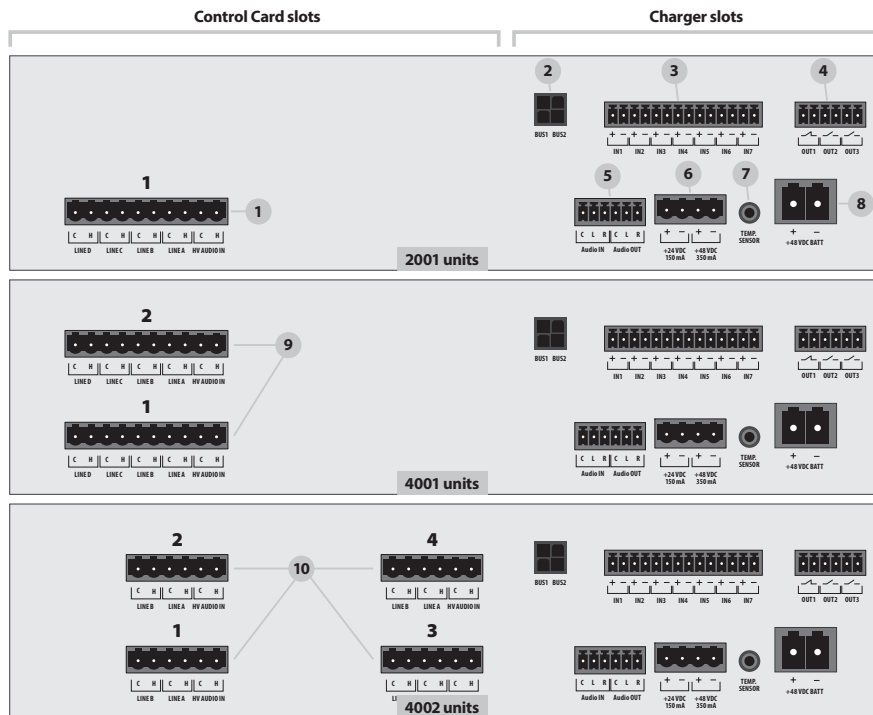

Fig. 3. Line control card arrangement for miniVES systems

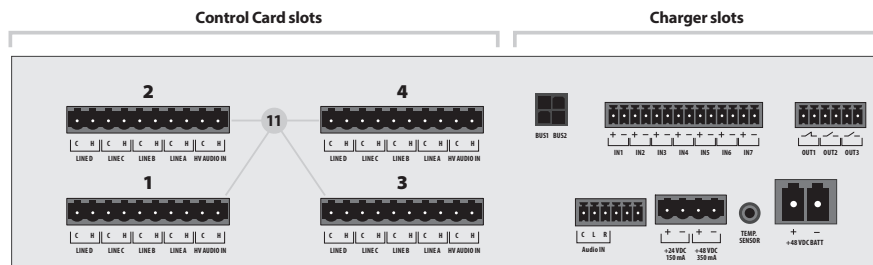

Fig. 4. Line control card arrangement for midiVES 8003 units

1. **ABT-xCtrLine-4 control card**
2. **Local audio bus outputs for 4 line control card operation**
3. **Logic inputs connector**
4. **Logic outputs connector**
5. **Audio I/O connector**
6. **Auxillary power outputs**
7. **Temperature sensor input jack**
8. **Main battery connector**
9. **Two ABT-xCtrLine-4 control cards**
10. **Four ABT-xCtrLine-2 control cards**
11. **Four ABT-xCtrLine-44 control cards**

3.1 miniVES L series and midiVES 8003R connector panel

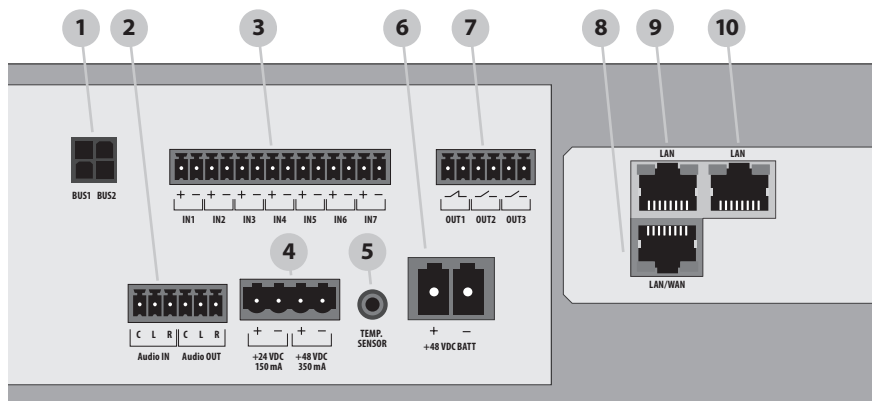

Fig. 5. Diagram of the connector panel for miniVES series 2001L, 4001L, 4002L and midiVES 8003R

1. **Local audio bus outputs for 4 line control card operation**
2. **Audio input and output (Audio out not available in midiVES 8003R)**
3. **Logic inputs**
4. **Auxillary power outputs**
5. **Battery temperature sensor input jack**
6. **Main Battery connector**
7. **Logic outputs**
8. **10/100 Mbps Lan/Wan port (PC connection)**
9. **10/100/1000 Mbps Lan port**
10. **10/100/1000 Mbps Lan port**

3.2 *miniVES LN, midiVES 8003 LN and 8003 LNR series connector panel*

miniVES LN series as well as midiVES 8003LN / LNR are equipped with extended xNET_mini 1GB/WAN/RS network card. Extended interface provides additional POE port, 2 logical inputs/ outputs and 2 optional SFP ports for fibre or copper redundant connection.

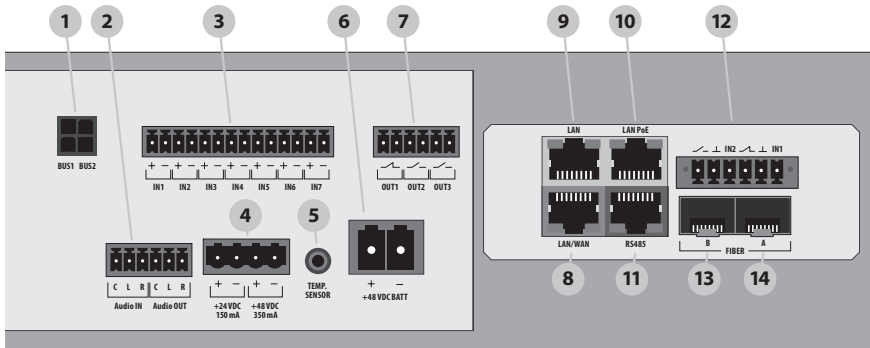

Fig. 6. Diagram of the connector panel for miniVES series 2001LN, 4001LN and 4002LN units

1. **Local audio bus outputs for 4 line control card operation**
2. **Audio input and output**
3. **Logic inputs**
4. **Auxillary power outputs**
5. **Battery temperature sensor input jack**
6. **Main Battery connector**
7. **Logic outputs**
8. **10/100 Mbps Lan/Wan port (PC connection)**
9. **10/100/1000 Mbps Lan port**
10. **10/100/1000 Mbps Lan port**
11. **RS485 Port**
12. **Additional Logic I/O ports**
13. **SFP module slot B**
14. **SFP module slot A**

4. miniVES charger

4.1 miniVES Charger

In order to connect the batteries to the charger use the battery cable supplied with the device. Be sure of proper connection (polarity) between batteries and terminals. Lastly connect the thermistor temperature sensor to the "TEMP SENSOR" jack and place it near installed batteries. Only unused and type compliant batteries (same manufacturer, equivalent capacity and voltage, same manufacturing date) may be connected.

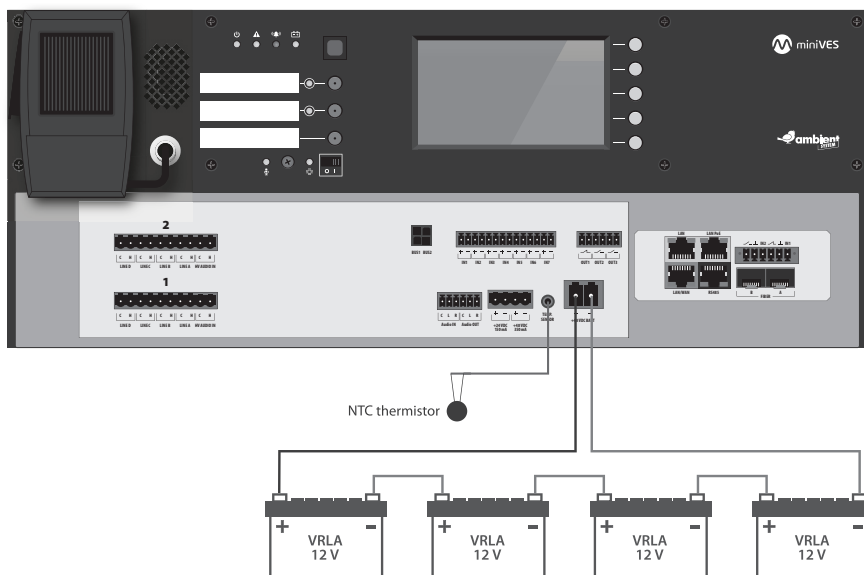

Fig. 7. Connection between VRLA batteries, temp. sensor and miniVES Charger module

▲ NOTE: It is crucial to connect the batteries to the system before startup.

Once the power supply has been provided, connect loudspeaker lines, logic inputs and outputs, network devices.

When you make sure all connections have been carried out properly, you can power up the system

Connecting midiVES 8003LNR with 8003R:

For connecting midiVES 8003LNR with 8003R we can use a single set of 4x12V (VRLA) batteries which is shared between 8003LNR and 8003R.

Please remember to set the capacity of the batteries on unit 8003LNR only and select no batteries option in 8003R when using the same batteries. Below are schematic how to connect batteries to the midiVES 8003LNR and 8003R using dedicated panel:

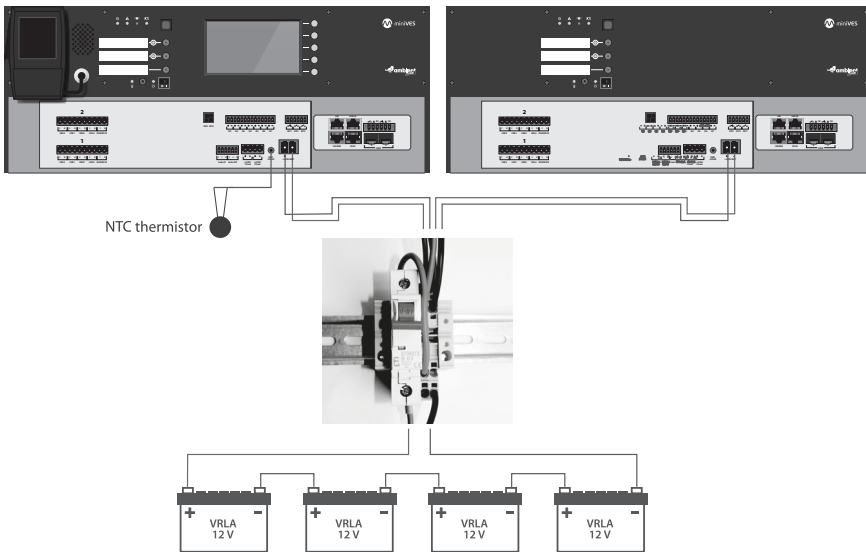

Fig. 8. Connecting midiVES 8003LNR with 8003R with a set of 4x12V batteries

4.2 Batteries

It is necessary to protect batteries from short-circuit while connecting battery leads. Short-circuit may lead to system failure. Follow this manual to assure safety while connecting.

Make sure the system power has been switched off before battery is connected.

Once the batteries have been connected, make sure all terminals of all batteries have been protected against short-circuit.

Connecting batteries

- » Wait over 10 seconds after the power cord was unplugged from AC socket located on the miniVES main unit.
- » Never connect negative cable in the first place as in the case of short-circuit between battery positive wire and a device frame or rack cabinet element, a device damage may occur.
- » Connect battery negative cable to negative terminal.

▲ NOTE: Battery bank has to be connected before connecting main power supply.

▲ In case of disconnecting batteries and lack of AC power please wait 60 seconds for fully discharge of miniVES before the battery pack will be reconnected to the system. Improper connection procedure may lead to charger module damage.

5. Instructions for performing basic functions

5.1 Alarm mode

Activating alarm mode

Lift red button flap (alarm button “activate Evacuation”) and press it. However miniVES system is not equipped with the red button protected by the flap. That means that pressing once the red button on the front panel of miniVES activates the 5 seconds procedure (Evacuation button starts blinking RED) during which the system waits for second press of the button. Finishing this two steps procedure activates Alarm Mode. Green LED indicators will emit light in all sound system zones. The system enters alarm state and automatically activates all zones. In this state, music background and zone microphones are disconnected. It is still possible to send automatic alarm messages or via fireman microphone. The system awaits messages to given zones. The alarm state applies until the programmed as “cancel alarm” is pressed.

Cancelling alarm

During alarm state, press “Cancel Alarm” button. VASCU enters standby mode, all alarm messages are muted and background music is restored.

Sending evacuation messages

Activate alarm and select zones. A green LED next to the zone name means the zone is ready to transmit. Press “Evacuation” button. A constant red indicator next to green zone selection indicator means that evacuation message is being sent. The evacuation message will be played back in given zones in a continuous way, until the button “cancel alarm” is pressed.

Sending warning messages

Activate alarm and select zones. A green LED next to the zone name means the zone is ready to transmit. Press “Warning” button. A flashing red indicator next to green zone selection indicator means that the warning message is being sent. The warning message will be played back in given zones in a continuous way, until the button “cancel alarm” is pressed.

Sending verbal messages via microphone

Activate alarm and select zones you wish to be received in. A green LED next to the zone name means the zone is ready to transmit. Lift the microphone, press and hold “push to talk” button while speaking.. Speak slowly, loud and clearly.

Message priorities

Activate alarm and select zones. Press “Warning” button – warning message will be played back in given zones. Next, press “Evacuation” button – warning message will stop, and evacuation message will replace it because has a higher priority. Then, press “push to talk” button – all automatic messages will stop and you will be able to transmit a live message via the fireman microphone.

Transmitting automatic messages and microphone messages in various zones

Activate alarm and select one zone. Activate evacuation message or warning message playback in the given zone. Unselect this zone (green indicator goes out, red one still emits a constant light or flashes). Select another zone. To send a verbal message, press and hold “Push to talk” button and speak to the microphone.

Transmitting verbal messages when the central processing unit is faulty – CPU OFF

Set the switch on the front panel in the CPU OFF position. The CPU OFF LED will light up with a steady green light. Press “push to talk” button and speak to the microphone.

▲ NOTE! When the switch is in the CPU OFF position, playback of the alarm messages recorded in the miniVES memory does not work. The processor is bypassed. A direct connection between devices is created: microphone → amplifiers → loudspeakers. Microphone input is broadcasted to the entire system. Amplifiers operate at maximum amplification – be aware that this rises the SPL significantly.

5.2 Failure mode

A flashing yellow FAILURE LED means that one of VAS central unit elements or a loudspeaker line is damaged. On miniVES devices and ABT-DFMS the system failure will be indicated by an acoustic signal. When the damage is signaled, press “confirm failure” button to mute the alarm sound, and the system will register that the failure was confirmed by the Operator (this event will be recorded in the event log). The failure LED goes out when the system failure is eliminated and “cancel failure” button is pressed.

A system maintenance technician or technical service must be notified of any damage immediately.

6. Technical data

6.1 miniVES 2001/4001/4002 L/N, 4002LNR

Model	miniVES 2001L, 4001L, 4002L	miniVES 2001LN, 4001LN, 4002LN, 4002LNR
Power supply	230 V AC, IEC C14 3pin terminal	
Power consumption	Up to 600 W (depending on configuration)	
Number of control slots	4	
Message storage	SD HC cards with capacities up to 32 GB supported The included 512 MB SLC SDHC card provides more than 20 min of message time	
LCD display	4,3" LCD touch screen	
DSP	Implemented 3 band parametric EQ	
Number of audio inputs	1	
Type of audio inputs	Unbalanced	
Connector type	3 pin phoenix connector	
Frequency response	40 Hz... 20 kHz (@1 dB) / 400 Hz... 8 kHz (@0,1 dB)	
Input impedance	250 Ω	
Maximum input voltage	≤ 3 Vrms	
Number of outputs	1	
Type of outputs	Balanced	
Connector type	3 pin phoenix connector	
Frequency response	40 Hz... 20 kHz (@1dB) / 400 Hz... 8 kHz (@0,1dB)	

Harmonic distortion (THD+IMD)	≤ 0,05%
Headroom	10 dB
SNR	≥ 90 dB
Channel separation	≥ 80 dB
Output impedance	600 Ω
Nominal output level	1 Vrms
Data communication	<p>Standard communication:</p> <ul style="list-style-type: none"> ↳ 1000BASE-TX/RJ45 CAT5E cables – 2 ports available on the connector panel ↳ 100BASE-TX/RJ45 CAT5 cables – 1 port available on the connector panel, for connections with an external network <p>Communication over large distances:</p> <ul style="list-style-type: none"> ↳ 1000BASE X optical fibre ↳ 2 ports providing a redundant connection <p>Standard communication:</p> <ul style="list-style-type: none"> ↳ 1000BASE-TX/RJ45 CAT5E cables – 2 ports available on the connector panel ↳ 100BASE-TX/RJ45 CAT5 cables – 1 port available on the connector panel, for connections with an external network
Fibre module connector type / fibre type	<p>SFP modules / SC/LC connector Multimode or single mode E30 or E90, OM or OM2</p>
Communication with PC	PC software: RJ45, twisted pair connection TIA/EIA568-B via Ethernet protocol
Operating temperature	-5°C / +40°C
Operating humidity	15% to 80% (non-condensing)
Storage temperature	-20°C / +70°C
Storage humidity	15% to 80% (non-condensing)

Case material and finish	Steel with powdercoat finish
Dimensions	439 (W) × 176 (H) × 354 (D) mm for 4002LNR 440 (W) × 525 (H) × 350 (D) mm for 2001/4001/4002 L/LN
Mount options	4 × 10 mm wall mount holes in the back of the case
Weight 2001	26 kg
Weight 4001	31 kg
Weight 4002	31,5 kg
Accessories	Battery cable, AC power connector, Handheld Microphone

6.2 **midiVES 8003R**

Model	midiVES 8003R
Power supply	230 V AC, IEC C14 3pin terminal
Power consumption	Up to 750 W (depending on configuration)
Number of control slots	4
Message storage	SD HC cards with capacities up to 32 GB supported The included 512 MB SLC SDHC card provides more than 20 min of message time
LCD display	None
DSP	Input EQ, outputs EQ, Feedback eliminator and audio limiter, delay up to 30000 ms
Number of audio inputs	1
No of speaker lines	16
No of control inputs	7
Control by	Programmable 4 buttons and color touch screen
No of relay outputs	3
No of messages played at the same time	3
Connector type	3 pin phoenix connector
Frequency response	20 Hz - 22kHz (+0,5 / -3dB) Rated power
Input impedance	250 Ω
Maximum input voltage	≤ 3 Vrms
Rated output voltage	100Vrms / 20 Ω, THD+N < 1%

Total Harmonic Distortion + Noise (THD+N) < 0,1%

Signal to Noise Ratio (SNR) > 76dB

Standard communication:

Data communication Ő 1000BASE-TX/RJ45 CAT5E cables – 2 ports available on the connector panel

 Ő 100BASE-TX/RJ45 CAT5 cables – 1 port available on the connector panel, for connections with an external network

Communication with PC PC software: RJ45, twisted pair connection TIA/EIA568-B via Ethernet protocol

Operating temperature -5°C / +40°C

Operating humidity 15% to 80% (non-condensing)

Storage temperature -20°C / +70°C

Storage humidity 15% to 80% (non-condensing)

Case material and finish Steel with powdercoat finish

Dimensions 439 (W) × 176 (H) × 354 (D) mm

Finish Black

Mounting method 19" rack or desk top

Ingress protection IP30

Weight 13,5 kg

Accessories Battery cable, AC power connector, Handheld Microphone

Protection Over-temperature, short circuit, overload, ground leakage

6.3 *midIVES 8003LNR, 8003LN*

Model	midIVES 8003LNR	midIVES 8003LN
Power supply	230 V AC, IEC C14 3pin terminal	
Power consumption	Up to 750 W (depending on configuration)	
Number of control slots	4	
Message storage	SD HC cards with capacities up to 32 GB supported The included 512 MB SLC SDHC card provides more than 20 min of message time	
LCD display	4,3" LCD touch screen	
DSP	Input EQ, outputs EQ, Feedback eliminator and audio limiter, delay up to 30000 ms	
Number of audio inputs	1	
No of speaker lines	16	
No of control inputs	7	
Control by	Programmable 4 buttons and color touch screen	
No of relay outputs	1x NC, 2x NO	
Switching current (Max.)	1 A peak *	
Switching voltage (Max.)	50 V AC/DC peak *	
Switching power (Max.)	30 W *	
No of messages played at the same time	3	
Connector type	3 pin phoenix connector	
Frequency response	20 Hz - 22kHz (+0,5 / -3dB) Rated power	
Input impedance	250 Ω	

Maximum input voltage	≤ 3 Vrms	
Rated output voltage	100Vrms / 20 Ω, THD+N < 1%	
Total Harmonic Distortion + Noise (THD+N)	< 0,1%	
Signal to Noise Ratio (SNR)	> 76dB	
Data communication	2 × SFP module 1 Gb/s, 1 × POE 1 Gb/s, 100 Mb/s, 1 × LAN 1 Gb/s, 100 Mb/s connection; RS485 port; 1 × LAN/WAN 100 Mb/s connection	
Fibre module connector type / fibre type	SFP modules / SC/LC connector Multimode or single mode E30 or E90, OM or OM2	
Communication with PC	PC software: RJ45, twisted pair connection TIA/EIA568-B via Ethernet protocol	
Operating temperature	-5°C / +40°C	
Operating humidity	15% to 80% (non-condensing)	
Storage temperature	-20°C / +70°C	
Storage humidity	15% to 80% (non-condensing)	
Case material and finish	Steel with powder coat finish	
Dimensions	439 (W) × 176 (H) × 354 (D) mm	439 (W) × 525 (H) × 350 (D) mm
Finish	Black	
Mounting method	19" rack or desk top	
Ingress protection	IP30	
Weight	14 kg	26 kg
Accessories	Battery cable, AC power connector, Handheld Microphone	
Protection	Over-temperature, short circuit, overload, ground leakage	

7. Mounting instructions

Due to the weight of the product, it is important that the wall-mounted system is installed securely. The unit must be fixed to a structure designed to support its weight. Depending on the substrate, fixing should be done with dedicated screws to avoid them unscrewing, coming loose, pulling out of the wall or the wall system falling. Failure to fix the unit correctly may cause an accident and consequent injury to operators and bystanders.

STEP 1

Remove 4 × M4 TORX screws from part A and take off the front panel.

STEP 2

Remove 5 × M3 screws from part B.

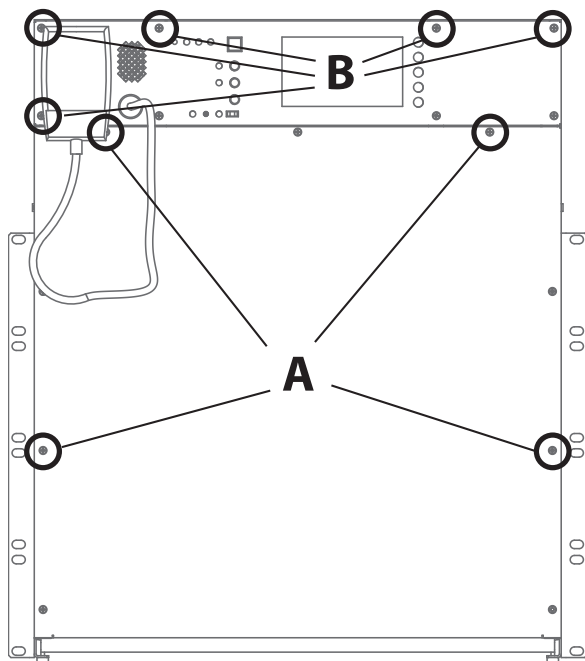

STEP 3

Remove Locking screws C and pull the drawer towards you D.

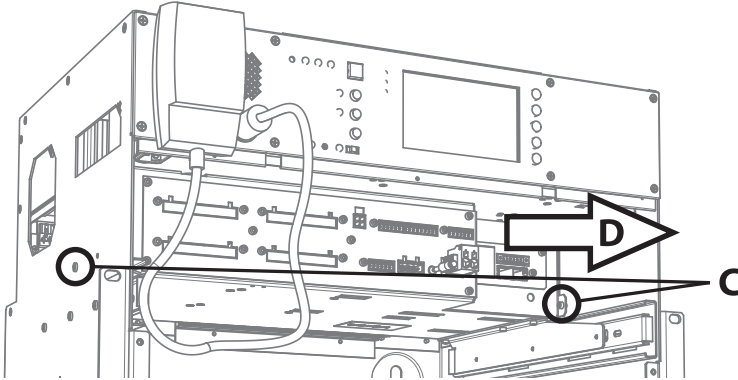

STEP 4

Drawer release lever.

1. To release, push down on lever on left hand side and pull up on lever on the right hand side.
2. With levers depressed, pull drawer towards you to remove it completely

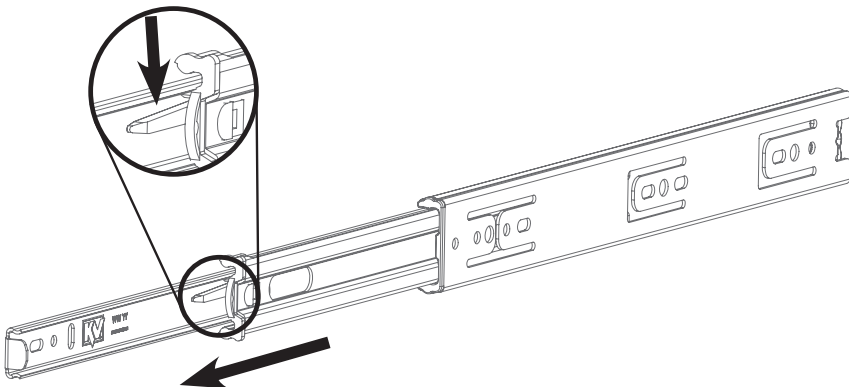

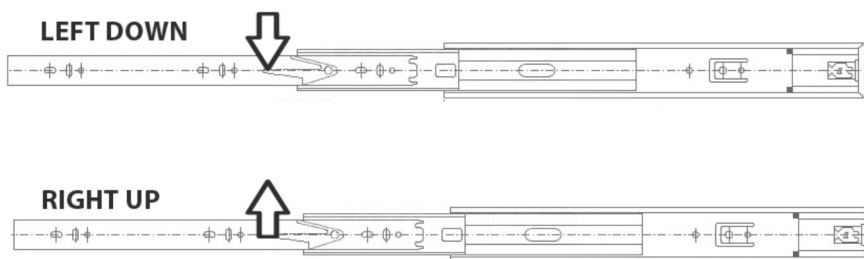

STEP 5

Fix the empty chassis to the wall with four screws.

Use screws and anchors suiting your type of wall (not provided).

- ▲ Due to the mass of the product (up to 80 kg with the batteries), it is important that the wall-mounted system is safely installed in accordance with local building regulations.**

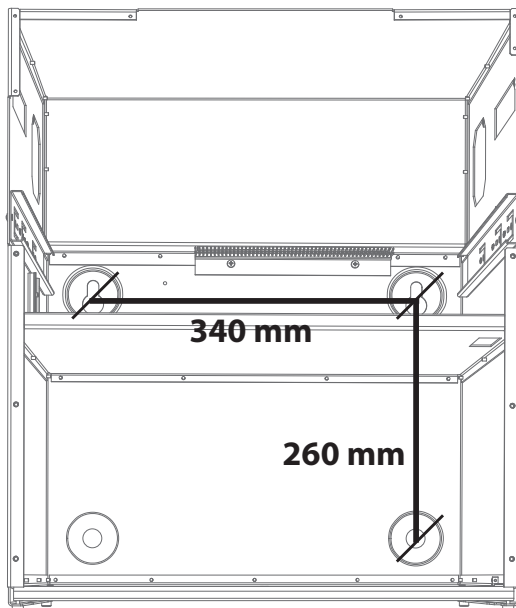

STEP 6

Add the batteries to the dedicated compartment.

Check that the battery compartment holds the type of battery selected by the installer.

A = 220 mm

B = 340 mm

C = 430 mm

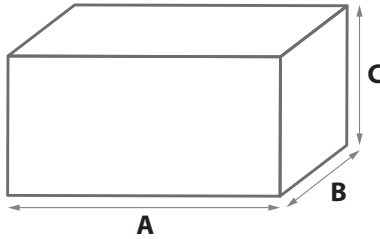

STEP 7

Slide the drawer back in position and tighten the screws.

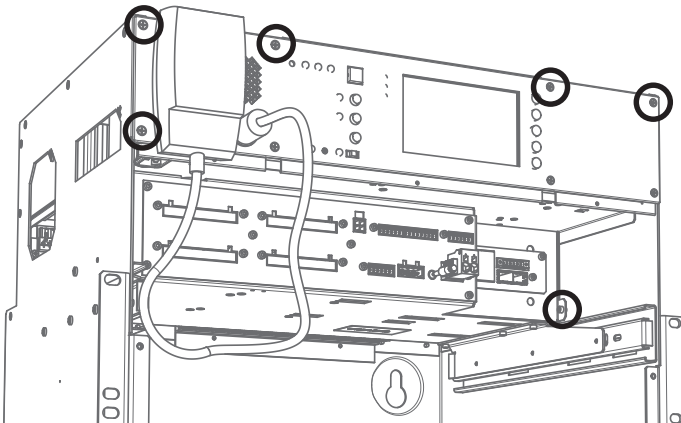

8. Notes

A series of horizontal dotted lines for taking notes.



17

Ambient System Sp. z o.o. | ul. Bysewska 27 | 80-298 Gdańsk | Poland
1438-CPR-0527

EN 54-16:2008

EN 54-4:1997 | EN 54-4:1997/AC:1999 | EN 54-4:1997/A1:2002 | EN 54-4:1997/A2:2006

Voice alarm control and indicating equipment with integrated power supply equipment

miniVES 2001 | miniVES 4001 | miniVES 4002
miniVES 2001L | miniVES 4001L | miniVES 4002L
miniVES 2001N | miniVES 400LN | miniVES 4002N
miniVES 2001LN | miniVES 4001LN | miniVES 4002LN | miniVES 4002LNR
midiVES 8003LN | midiVES 8003R | midiVES 8003LNR

Declared intended use of product: Fire safety

Optional functions:

Delays to entering the voice alarm condition | Phased evacuation
Manual silencing of the voice alarm condition | Manual reset of the voice alarm condition
Voice alarm condition output | Indication of faults related to voice alarm zones
Disablement condition | Voice alarm manual control
Emergency microphone | Redundant power amplifiers

Other technical data: see „Technical documentation“



We make everyday life safer

Ambient System Sp. z o.o.

ul. Bysewska 27 | 80-298 Gdańsk | Poland
T: +48 58 345 51 95 | ambient@ambientsystem.eu