



We make everyday life safer

Compact Voice Alarm System



miniVES



midiVES

EN

Service Manual

EN 54-16: 2008

EN 54-4: 1997 + A1: 2002 + A2: 2006



ver. 10.2021

Table of Contents

1. Safety	5
2. Ambient System Presentation	9
3. miniVES & midiVES system presentation	10
4. Symbols used in the document	14
5. Warranty conditions	15
6. Requirements	16
6.1 Unpacking	16
6.2 Installation requirements	17
6.3 Environmental conditions	17
7. Device description	18
7.1 Internal devices	18
7.1.1 Control units	18
7.1.1.1 miniVES series 2001, 4001 and 4002 units	19
7.1.1.2 miniVES series 2001N, 4001N, 4002N	21
7.1.1.3 miniVES series 2001L, 4001L and 4002L units	25
7.1.1.4 miniVES series 2001LN, 4001LN, 4002LN	26
7.1.1.5 midiVES 8003R unit	30
7.1.1.6 midiVES series 8003LN, 8003LNR units	35
7.1.1.7 DFMS Box	39
7.1.2.1 ABT-xNET_mini-1Gb/WAN/RS communication card	39
7.1.2.2 ABT-xNET_mini-1Gb communication card	41
7.1.2.3 ABT-xCtrLine-4 – Control card of 4 loudspeaker lines	43
7.1.2.4 ABT-xCtrLine-2 – 2 loudspeaker lines control card	45
7.1.2.5 ABT-xCtrLine-44 – Control card of 4 loudspeaker lines	48
7.1.2.6 Loop monitor board LM8200 for short isolators	50
7.1.3 Assembly and connection of ABT-LMK Master and ABT-LMK extension sets	59
7.1.4 Built in amplifier modules	63
7.1.4.1 Technical details	63
7.1.5 miniVES Charger	64
7.2 External devices	67
7.2.1 ABT-DFMS fireman microphone	67
7.2.2 ABT-DMS zone microphone	71
7.2.3 ABT-DMS-LCD – zone microphone with LCD	74
7.2.4 ABT-EKB-20M – microphone keyboard extension	77
7.2.4.1 Functional buttons performance	78
7.2.4.2 Functional buttons signaling	78
7.2.4.3 Extension connector	79
7.2.7 ABT-M01 Microphone	83

8. System hardware installation	85
8.1 Information on limiting damage consequences	85
8.2 General connection diagram	85
8.3 Connecting devices	86
8.3.1 Control units	87
8.3.1.1 Daisy Chain Topology	87
8.3.1.2 Power and Lan Configuration	88
8.3.1.3 DIP Switch Configuration	88
8.3.1.4 Use of CTC VDTU2-B140-DC	89
8.3.1.5 Example of Use with Systems - Point to Point Connection	89
8.3.1.6 Ring Topology	91
8.3.2 Batteries	93
8.3.3 Microphones	95
8.3.3.1 Fireman microphone RING-type optic fiber connection	95
8.3.3.2 Fireman microphone CHAIN-type cable connection	96
8.3.3.3 Different ways to power the fireman microphone	96
8.3.3.4 Zone microphones – types of connection	98
8.3.3.5 Connecting power to zone microphones	100
8.4 Preparing sound system for VAS application	101
9. Operation modes – LED colors	103
9.1 Normal mode	105
9.2 Alarm mode	105
9.3 Failure mode	105
9.4 Lock mode	105
10. Instruction for performing tests and trials	106
10.1 Instructions for performing basic functions	106
10.1.1 Alarm mode	106
10.1.2 Failure mode	107
10.1.3 Controlling backup power batteries	107
10.2 Testing the system	108
11. Operation instructions	109
11.1 Control Unit	109
11.2 Fireman microphone	109
11.3 Zone microphone	111
12. Maintenance and service	112
12.1 Preparations before VAS system maintenance works	112
12.1.1 Initial procedures for system testing	112
12.1.2 System testing	112
12.2 System maintenance	113
12.2.1 Daily review	113
12.2.2 Inspection every 6 months	113

12.2.3 Annual inspection	115
12.2.4 Manufactures remarks	115
13. Configuration Software	116
13.1 Welcome screen	116
13.2 Basic Configuration	117
13.3 System Configuration	119
13.3.1 File	120
13.3.2 Preferences	121
13.3.3 System	122
13.3.4 System Connection Settings	124
13.3.5 Workspace	125
13.3.6 Central Unit Configuration	126
13.3.7 DFMS	132
13.3.8 DMS	135
13.3.9 DMS-LCD	137
13.3.10 xCtrlLine-2/4	138
13.4 Priority Manager Configuration	139
13.5 Group Zone Configuration	141
13.6 Control I/O Configuration	142
13.6.1 Group Logical Inputs	142
13.6.2 Group Logical Outputs	143
13.6.3 Timers	145
13.7 Matrix Configuration	146
13.8 Scenario Configuration	148
13.9 Event Configuration	150
13.9.1 Functions	152
13.10 The Amplifier Output Manager Tab	164
13.11 Reports	167
13.12 Basic steps required to program the system	168
13.13 Glossary	169
13.14 FAQ	170
13.15 Appendix	172
14. miniVES / midiVES system touchscreen user manual	177
15. Annexes	190
16. Certificates	191
17. Glossary	192
18. List of tables	193
19. List drawings	194

1. Safety



Danger!

High risk: This symbol indicates an imminently hazardous situation such as "Dangerous Voltage" inside the product. If not avoided, this will result in an electrical shock, serious bodily injury, or death.



Warning!

Medium risk: Indicates a potentially hazardous situation. If not avoided, this could result in minor or moderate bodily injury.



Caution!

Low risk: Indicates a potentially hazardous situation. If not avoided, this could result in property damage or risk of damage to the unit.

- 1 **Read these instructions.** All the safety and operating instructions should be read before the apparatus or system is operated.
- 2 **Keep these instructions.** The important safety instructions and operating instructions should be retained for future reference.
- 3 **Heed all warnings.** All warnings on the apparatus and in the operating instructions should be adhered to.
- 4 **Follow all instructions.** All instructions for installation or use/operating should be followed.
- 5 **Do not use this apparatus near water.** Do not use this apparatus near water or a moist environment – for example, near a bath tub, wash bowl, kitchen sink, or laundry tub, in a wet basement, near a swimming pool, in an unprotected outdoor installation, or any area which is classified as a wet location.
- 6 **Clean only with dry cloth.** Unplug the apparatus from the outlet before cleaning. Do not use liquid cleaners or aerosol cleaners.
- 7 **Do not block any ventilation openings. Install in accordance with the manufacturer's instructions.** Openings in the enclosure, if any, are provided for ventilation and to ensure reliable operation of the apparatus and to protect it from overheating. These openings must not be blocked or covered. This apparatus should not be placed in a built-in installation unless proper ventilation is provided or the manufacturer's instructions have been adhered to.
- 8 **Do not install near any heat sources such as radiators, heat registers, stoves, or other apparatus (including amplifiers) that produce heat or in direct sunlight.**
- 9 **No naked flame sources, such as lighted candles, should be placed on the apparatus.**
- 10 **Do not defeat the safety purpose of the polarized or ground-type plug.** A polarized plug has two blades with one wider than the other. A grounding type plug has two blades and a third grounding prong. The wider blade or the third prong are provided for your safety. If the provided plug does not fit into your outlet, consult an electrician for replacement of the obsolete outlet.
- 11 **Protect the power cord from being walked on or pinched particularly at plug, convenience receptacles, and the point where they exit from the apparatus.**
- 12 **Only use attachments/accessories specified by the manufacturer.** Any mounting of the apparatus should follow the manufacturer's instructions, and should use a mounting accessory recommended by the manufacturer.
- 13 **Use only with the cart, stand, tripod, bracket or table specified by the manufacturer, or sold with the apparatus.** When a cart is used, use caution when moving the cart/apparatus combination to avoid injury from tip-over. Quick stops, excessive force, and uneven surfaces may cause the appliance and cart combination to overturn.
- 14 **Unplug this apparatus during lightning storms or when unused for long periods of time.** Not applicable when special functions are to be maintained, such as evacuation systems.

- 15 **Refer all servicing to qualified service personnel.** Servicing is required when the apparatus has been damaged in any way, such as power-supply cord or plug is damaged, liquid has been spilled or objects have fallen into the apparatus, the apparatus has been exposed to rain or moisture, does not operate normally, or has been dropped.
- 16 **Avoid mechanical shocks.** Strong impacts and shocks may damage the device. Transport the device carefully and avoid dropping it.
- 17 **The apparatus shall not be exposed to dripping or splashing and that no objects filled with liquid, such as vases, shall be placed on the apparatus.**
- 18 **Batteries (battery pack or batteries installed) shall not be exposed to excessive heat such as sunshine, fire or the like.**

**Caution!**

Danger of explosion if battery is incorrectly replaced. Replace only with the same or equivalent type. Dispose of used batteries according to the environmental law and procedures.

- 19 **Professional installation only.** Do not use this equipment in residential applications.
- 20 **Condensation.** In order to avoid condensation; wait a few hours before turning on the equipment when it is transported from a cold to a warm space.
- 21 **Hearing damage.** For apparatus with audio output, to prevent possible hearing damage, do not listen at high volume levels for long periods.
- 22 **Do not disassemble the device or attempt to repair or modify it.** The device does not include user replaceable components inside the chassis. Opening the chassis and unauthorized repairs will void the warranty. Unauthorized substitutions may result in fire, electric shock or other hazards.
- 23 **Safety check.** Upon completion of any service or repairs to this apparatus, ask the service technician to perform safety checks to determine that the apparatus is in proper operating condition.

**Danger!**

Overloading – do not overload outlets and extension cords as this can result in a risk of fire or electric shock.

- 24 **Power sources.** This apparatus should be operated only from the type of power source indicated on the marking label. If you are not sure of the type of power supply you plan to use, consult your appliance dealer or local power company. For apparatuses intended to operate from battery power, or other sources, refer to the operating instructions.
- 25 **Power lines.** An outdoor system should not be located in the vicinity of overhead power lines or other electric light or power circuits, or where it can fall into such power lines or circuits. When installing an outdoor system, extreme care should be taken to keep from touching such power lines or circuits, as contact with them might be fatal.

**Danger!**

Object and Liquid entry – never push objects of any kind into this apparatus through openings as they may touch dangerous voltage points or short-out parts that could result in a fire or electric shock. Never spill liquid of any kind on the apparatus.

- 26 **Protective grounding.** An apparatus with class I construction shall be connected to a power outlet socket with a protective grounding connection.
Protective earthing. An apparatus with class I construction shall be connected to a mains socket outlet with a protective earthing connection.
- 27 **Due to the weight of the product, it is important that the wall-mounted system is installed securely.** The unit must be fixed to a structure designed to support its weight. Depending on the substrate, fixing should be done with dedicated screws to avoid them unscrewing, coming loose, pulling out of the wall or the wall system falling.

**Caution!**

Failure to fix the unit correctly may cause an accident and consequent injury to operators and bystanders.

Note for power connections

- For permanently connected equipment, a readily operable mains plug or all-pole mains switch shall be external to the equipment and in accordance with all applicable installation rules.
- For pluggable equipment, the socket-outlet shall be installed near the equipment and shall be easily accessible.



This label may appear on the bottom of the apparatus due to space limitations.



Caution!

To reduce the risk of electrical shock, DO NOT open covers. Refer servicing to qualified service personnel only.



Warning!

To prevent fire or shock hazard, do not expose units to rain or moisture.



Warning!

Installation should be performed by qualified service personnel only in accordance with the National Electrical Code or applicable local codes.



Warning!

Power disconnect: If the apparatus is mains powered and a power supply cord set is provided, the disconnect device is the mains plug of the power cord set.

If an AC DC adapter is provided and the mains plug that is part of the direct plug in device, the AC DC adapter is the disconnect device. The socket outlet shall be near the apparatus and shall be easily accessible.



Old electrical and electronic appliances

Electrical or electronic devices that are no longer serviceable must be collected separately and sent for environmentally compatible recycling (in accordance with the European Waste Electrical and Electronic Equipment Directive).

To dispose of old electrical or electronic devices, you should use the return and collection systems put in place in the country concerned.



Only used at altitude not exceeding 2000 m.



Only used in non-tropical climate regions.

Impact on the environment



This product was marked in accordance with WEEE Directive (2002/96/EC) and further amendments on waste electrical and electronic equipment. Assuring a proper scrapping, you contribute to reduction of risk of negative impact on the environment and people's health, which would occur in the case of improper equipment disposal. The symbol located on the product or attached documents means that our product has not been classified as domestic waste. The equipment must be transported to a suitable waste treatment plant in order to recycle it.

To see more details about recycling our product, contact a local authority representative, waste treatment service provider or the store where our product was sold. Pursuant to the act of 29 July 2005 on waste electronic and electrical equipment, it is forbidden to dispose of the waste electronics along with other (municipal) waste because such actions entail criminal penalties. Packaging elements were made of cardboard and polyethylene foam. For this reason, they may be subject to recycling. In so doing, redundant packaging must be sorted out in accordance with their intended use and delivered to the local waste collector.

In the interest of protecting human's health and environment, we assure that our products, subject to RoHS 2011/65/EU directive provisions on the use of hazardous substances in electric and electronic equipment, have been designed and manufactured in accordance with requirements of this directive.

2. Ambient System Presentation

With more than twenty years of experience, Ambient System has quickly established itself as a leading manufacturer of Public Address, Voice Alarm systems and counter intercoms. The constant growth of market share in Europe provides confirmation of the quality of Ambient System commercial and technical approach.

Products:

The company now offers a full range of sound equipment: microphones, preamplifiers, digital processors, digital audio matrixes, loud-speaker monitoring systems, amplifiers, etc. AMBIENT SYSTEM designs and manufactures leading products in the voice alarm systems market which have been certified EN 54-4, EN 54-16, EN 54-24 compliant.

Development:

Thanks to a development team that includes thirty engineers, and to constant investment, we are able to respond rapidly to the demands of our various markets with specific solutions and cutting edge technology. We have distributors in more than fifteen countries in Europe and the Middle East, with whom we have carried out major projects.

In choosing Ambient System, you are guaranteed a trustworthy partner that can be counted on for the long term.

Ambient System Field:

Ambient System's audio systems have been installed in the following markets:

- » Railways,
- » Subways,
- » Airports,
- » High rise buildings,
- » Hotels,
- » Restaurants,
- » Shopping malls,
- » Theme parks,
- » Places of worship,
- » Stadiums,
- » Museums,
- » Industrial buildings,
- » Industrial plants,
- » Commercial buildings.

3. miniVES & midiVES system presentation

midIVES is the latest product promoted by Ambient System, the company specializing in production of reliable and certified voice alarm systems. midIVES is a Public Address & Voice Evacuation system based on optical fibre digital transmission of voice, alarm and commercial messages.

midIVES and miniVES VAS central unit has been designed in accordance with the European EN 54-16 norm.

In accordance with the internal regulations of CEN/CENELEC, the organizations for standardization of the following countries are obligated to introduce this European standard:

Austria, Belgium, Bulgaria, Cyprus, the Czech Republic, Denmark, Estonia, Finland, France, Germany, Greece, Hungary, Island, Ireland, Italy, Lithuania, Latvia, Luxembourg, Malta, the Netherlands, Norway, Poland, Portugal, Romania, Spain, Slovakia, Slovenia, Sweden, Switzerland and Great Britain.

miniVES and midIVES system includes the following: control devices, fireman microphone panels and zone microphones. All components are certified (officially approved). The system rests on a modern platform which allows a digital scalable communication between all elements of the system, as well as between other integrated safety systems.

miniVES and midIVES system has been developed with various applications in mind – it is perfect for both decentralized and centralized systems.

The system architecture is based on optical connection between control unit devices and other system elements. It allows creation of highly large facilities, such as airport terminals, oil fields and refineries, shopping centers or office complexes.

At the same time, along with the customized construction of control unit and network types, we are able to create compact systems for single small and middle-sized facilities, as well as larger groups connected by a digital network.

The following components account for integrated concept of miniVES / midIVES system VAS central unit:

miniVES 2001 unit

miniVES 2001N unit

miniVES 2001L unit

miniVES 2001LN unit

miniVES 4001 unit

midIVES 8003R unit

miniVES 4001N unit

miniVES 4001L unit

miniVES 4001LN unit

midIVES 8003LNR unit

miniVES 4002 unit

miniVES 4002N unit

miniVES 4002L unit

miniVES 4002LN unit

midIVES 8003LN unit

miniVES 4002LNR unit

DFMS Box unit

4 loudspeaker line control card ABT-xCtrLine-4 / ABT-xCtrLine-44

2 loudspeaker line control card ABT-xCtrLine-2

ABT-DFMS fireman microphone

ABT-DMS zone microphone

ABT-DMS-LCD zone microphone with display

ABT-EKB-20M microphone keyboard extension

Optional features in accordance with EN 54-16 standard:

Sound signaling	x
Delayed voice alarm introduction	✓
Gradual evacuation	✓
Manual voice alarm muting	✓
Manual voice alarm cancelling	✓
Fire alarm device outputs	x
Voice alarm output	✓
Signaling damage related to transmission track to FACIE	✓
Signaling damage related to voice alarm zones	✓
Lock status	✓
Manual control of voice alarm	✓
Digital interface between VASCU and external control devices	x
Emergency microphones	✓
Back-up power amplifier	✓

 DEKLARACJA WŁAŚCIWOŚCI UŻYTKOWYCH
 DECLARATION OF PERFORMANCE





Deklaracja właściwości użytkowych

Declaration of Performance



Nr/No miniVES-20210525

1.	Produkt Product	Centrala Dźwiękowego Systemu Ostrzegawczego Emergency Sound System
2.	Niepowtarzalny kod identyfikacyjny typu wyrobu Type of construction product	<p>miniVES _ midiVES</p> <p>Elementy składowe: / Components: miniVES 2001, miniVES 2001R, miniVES 2001L, miniVES 2001N, miniVES 2001LN, miniVES 4001, miniVES 4001R, miniVES 4001L, miniVES 4001N, miniVES 4001LN, miniVES 4002, miniVES 4002R, miniVES 4002L, miniVES 4002N, miniVES 4002LNR, miniVES 4002LN, midiVES 8003L, midiVES 8003LN, midiVES 8003 LR, midiVES 8003 LNR, midiVES 8003 R, DFMS BOX, DFMS BOX-L, ABT-XNET_MINI_1GB/WAN/RS, ABT-XNET_MINI_1GB/WAN, ABT-XCTRLINE-2, ABT-XCTRLINE-4, ABT-XCTRLINE-44, LM8200, TF-06-01, DDR-30L-24, ABT-EOL, IS8200-1, SF-MM31002D-GP, SF-MM31/55WD055D-GP, SF-MM31/55WD055-GP, SF-MMS31/55WD055D-GP, SF-MMS31/55WD055-GP, SF-SM31/55WD020D-GP, SF-SM31/55WD020D-GP, SF-SMS31/55WD020D-GP, SF-SMS31/55WD020-GP, SFP-1GBT-06, SF-CP100C-GP, ABT-XLCD, ABT-REG1, ABT-NSC6, ABT-NSM A / B, ST-POE8P-A, ST-POE4P-A, ST-POE1R-P, FS116P, FS116PV2, FS108P, GS 110TP, CTC VDTU2-B140 DC, ABT-IC-1K1, ABT-OCIP INDOOR01, ABT-ICO MODULE-1, MASTERLOCK MULLER S.C. 95 47 PRO, OYYOSS PMS-05, MINIPC-W2</p>
3.	Numer typu, partii lub serii lub jakiegokolwiek inny element umożliwiający identyfikację wyrobu budowlanego Type, batch or serial number or any other element allowing identification of the construction product	Zobacz etykietę znaku CE i oznaczenia na tabliczce See CE mark label and marking on boards
4.	Zamierzone zastosowanie Declared intended use of product	Bezpieczeństwo pożarowe Fire Safety
5.	Producent Manufacturer	Ambient System Sp. z o.o. ul. Bysewska 27, 80-298 Gdańsk, Polska
6.	System oceny i weryfikacji stałości użytkowych System of AVCP	1
7.	Jednostka notyfikowana Notified body	CNBOP-PIB 1438-CPR-0527

Example of VASCU miniVES rating plate

<h1>miniVES 2001LN</h1> <table border="1"> <tr> <td>Certyfikat zgodności z EN 54-4, EN 54-16 // Certificate of constancy of performance EN 54-4, EN 54-16</td> <td>1438-CPR-0527</td> </tr> <tr> <td>Świadectwo dopuszczenia CNBOP-PIB // Certificate of admission CNBOP-PIB</td> <td>2909/2017</td> </tr> <tr> <td>Deklaracja właściwości użytkowych / Declaration of Performance</td> <td>miniVES-20200525</td> </tr> <tr> <td>Przeznaczenie // Declared intended use of product</td> <td>bezpieczeństwo pożarowe // fire safety</td> </tr> <tr> <td>Zgodny z normą // Comply with</td> <td>EN 54-4 / EN 54-16</td> </tr> <tr> <td>Stopień ochrony IP // Ingress Protection Rating</td> <td>30</td> </tr> </table>		Certyfikat zgodności z EN 54-4, EN 54-16 // Certificate of constancy of performance EN 54-4, EN 54-16	1438-CPR-0527	Świadectwo dopuszczenia CNBOP-PIB // Certificate of admission CNBOP-PIB	2909/2017	Deklaracja właściwości użytkowych / Declaration of Performance	miniVES-20200525	Przeznaczenie // Declared intended use of product	bezpieczeństwo pożarowe // fire safety	Zgodny z normą // Comply with	EN 54-4 / EN 54-16	Stopień ochrony IP // Ingress Protection Rating	30	 	SN
		Certyfikat zgodności z EN 54-4, EN 54-16 // Certificate of constancy of performance EN 54-4, EN 54-16	1438-CPR-0527												
Świadectwo dopuszczenia CNBOP-PIB // Certificate of admission CNBOP-PIB	2909/2017														
Deklaracja właściwości użytkowych / Declaration of Performance	miniVES-20200525														
Przeznaczenie // Declared intended use of product	bezpieczeństwo pożarowe // fire safety														
Zgodny z normą // Comply with	EN 54-4 / EN 54-16														
Stopień ochrony IP // Ingress Protection Rating	30														
 <p>Producent / Manufacturer: Ambient System Sp. z o.o. Gdańsk 80-298, ul. Bysewska 27</p>															

Example of VASCU midiVES rating plate

<h1>midiVES 8003LN</h1> <table border="1"> <tr> <td>Certyfikat zgodności z EN 54-4, EN 54-16 // Certificate of constancy of performance EN 54-4, EN 54-16</td> <td>1438-CPR-0527</td> </tr> <tr> <td>Świadectwo dopuszczenia CNBOP-PIB // Certificate of admission CNBOP-PIB</td> <td>2909/2017</td> </tr> <tr> <td>Deklaracja właściwości użytkowych / Declaration of Performance</td> <td>midiVES-20200825</td> </tr> <tr> <td>Przeznaczenie // Declared intended use of product</td> <td>bezpieczeństwo pożarowe // fire safety</td> </tr> <tr> <td>Zgodny z normą // Comply with</td> <td>EN 54-4 / EN 54-16</td> </tr> <tr> <td>Stopień ochrony IP // Ingress Protection Rating</td> <td>30</td> </tr> </table>		Certyfikat zgodności z EN 54-4, EN 54-16 // Certificate of constancy of performance EN 54-4, EN 54-16	1438-CPR-0527	Świadectwo dopuszczenia CNBOP-PIB // Certificate of admission CNBOP-PIB	2909/2017	Deklaracja właściwości użytkowych / Declaration of Performance	midiVES-20200825	Przeznaczenie // Declared intended use of product	bezpieczeństwo pożarowe // fire safety	Zgodny z normą // Comply with	EN 54-4 / EN 54-16	Stopień ochrony IP // Ingress Protection Rating	30	 	SN
		Certyfikat zgodności z EN 54-4, EN 54-16 // Certificate of constancy of performance EN 54-4, EN 54-16	1438-CPR-0527												
Świadectwo dopuszczenia CNBOP-PIB // Certificate of admission CNBOP-PIB	2909/2017														
Deklaracja właściwości użytkowych / Declaration of Performance	midiVES-20200825														
Przeznaczenie // Declared intended use of product	bezpieczeństwo pożarowe // fire safety														
Zgodny z normą // Comply with	EN 54-4 / EN 54-16														
Stopień ochrony IP // Ingress Protection Rating	30														
 <p>Producent / Manufacturer: Ambient System Sp. z o.o. Gdańsk 80-298, ul. Bysewska 27</p>															

4. Symbols used in the document

**Warning!**

This symbol means a potentially hazardous situation posing a death or disability hazards

**Attention!**

This symbol means potentially hazardous situation posing medium or minor injuries and/or material loss hazards.

**Warning!**

This symbol means that using the above-mentioned products increases the risk of visual impairment.

5. *Warranty conditions*

Warranty conditions are a part of General Terms & Conditions of Delivery available at: www.ambientsystem.eu/en

6. Requirements

Unused devices must be stored in the original packaging, in enclosed rooms with the ambient temperature ranging from -20°C to 70°C and relative humidity – from 5% to 95% (without condensation).

Once the device has been moved from cold to warm environment, there is a risk of water condensation, which has a negative impact on device performance. In such case, it is necessary to leave the device to let it adapt to a new surrounding for about an hour before the operation.

During the transport, the devices should be packed in a way assuring reduced risk of mechanical damage and impact of weather conditions.

- ⚠ miniVES / midiVES should only be transported vertically, as indicated on the carton of the device;**
- ⚠ miniVES / midiVES should be transported only on a transport pallet (wooden or plastic) up to 3 stacking units. Additional load stabilization methods such as plastic stretch wrap, shrink wrap, plastic or stretch tape is required for additional securement.**

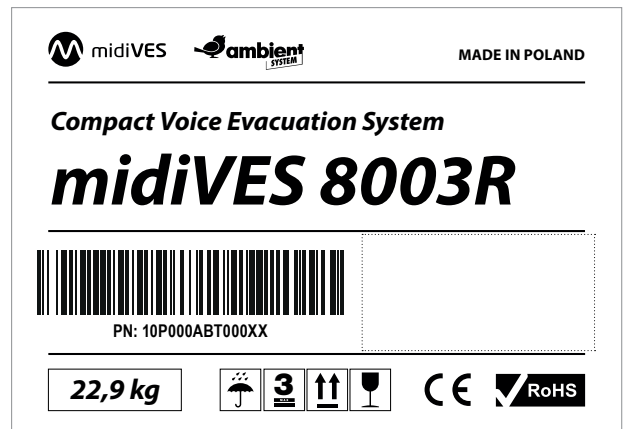
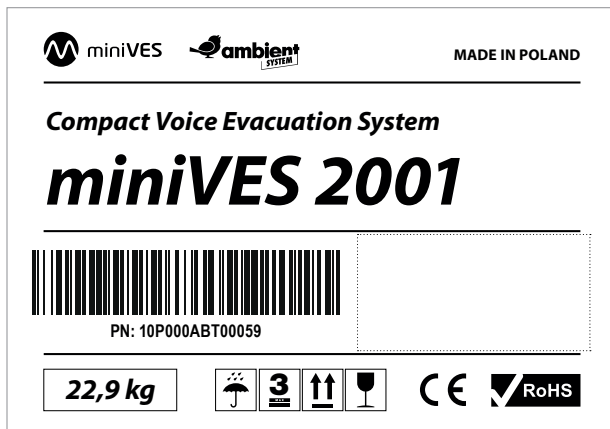

6.1 Unpacking

Please read this service manual to get familiar with relevant details concerning installation, operation, nature and product functions. If it is necessary to return the product to the service point, wrap the device into the original packaging (or identical to the original one).

6.2 Installation requirements

The alarm central unit room, in which VASCU is located, must satisfy the following conditions:

- » Fire protection device operation room (FPDOR) should be located on the floor of the structure, close to entrance/exit designed and marked as the entrance for rescue teams.
- » The room must be located and marked in a way that allows rescuers to notice it at the entrance. It is advisable to make sure FPDOR access doors are not located farther than 10m from rescue team exit.
- » The width of passage leading to the room should be at least 1,5 m.
- » The room should be properly marked.
- » If FPDOR is located at a distance greater than 10 m from the rescue team exit, additional signs must be used in order to point location and direction to FPDOR.
- » The Fire Safety Instructions in graphics and site evacuation procedures should include signs and location of FPDOR.
- » Install the Manual Call Point in FPDOR or in its immediate vicinity. FPDOR should be monitored by automatic sensors being part of fire alarm system on the site.
- » Access to FPDOR should be given solely to authorized persons and rescue team. It is acceptable to lock the door as long as one key is located in a suitably marked box with breakable glass attached to the wall in immediate vicinity to room doors.
- » FPDOR should be a closed room whose walls and ceilings have REI 60 fire resistance rating. The door of FPDOR should have EI30 fire resistance rating.
- » The control desk with a fireman microphone should be connected to VASCU via wires assuring circuit continuity in case of fire.
- » Natural and artificial lighting should be provided. Lighting intensity in the room must be min. 500 lx.
- » The room must be equipped with emergency lighting of an average lighting intensity – min. 10 lx.
- » Weather conditions must satisfy the following requirements: temperature from 0°C to +40°C, relative humidity from 25% to 80%, air pressure from 860 hPa to 1060 hPa.
- » A suitable amount of space around front VASCU board must be provided in order to allow required manipulations.
- » The height of control and indication devices assembly should allow their suitable operation.
- » Background noisevalues in the room, in which the console with the fireman microphone is located, should not exceed 40 dB.
- » A table with dimensions big enough to unfold site and system documentations must be located in the room.

6.3 Environmental conditions

Do not place the product in the environment which may affect its performance or shorten its life. Environments which have a negative influence frequently have high temperatures, are dusty, humid and have high level of vibrations. The equipment must be placed in cold and dry area far away from direct sunlight and inflammable and explosive materials.

The miniVES system is designed to either be mounted in a 19" RACK cabinet or to be mounted on a wall as a standalone device. Even without the additional casing it is rated at IP30 and thus compliant with the EN54-16 norm.

7. Device description

This section provides an insight into miniVES / midiVES system components:

- » **Control units**
- » **Extension cards**
- » **Microphones and microphone extensions**

7.1 Internal devices

7.1.1 Control units

A control unit is the main element of the system which receives audio signal and sends it to the entire system. This device manages all other elements. This component allows flexible configuration of audio signal tracks from any source of signal to any output. Global audio track switch is possible on the basis of the programmable logic system and Ethernet 1G (UDP/IP,TCP/IP) network.

miniVES system offers thirteen various control units:

- » **miniVES 2001 unit**
to be used as a secondary unit or for smaller site applications. Unit equipped with a single xCtrLine-4 card and a basic xNET_mini card
- » **miniVES 2001N unit**
similar to the 2001 unit, additionally equipped with the xNET_mini-1Gb/WAN/RS card with extended networking capabilities
- » **miniVES 2001L unit**
primary system unit, equipped with an LCD screen
- » **miniVES 2001LN unit**
similar to the 2001L unit with the addition of the xNET_mini-1Gb/WAN/RS card with extended networking capabilities
- » **miniVES 4001 unit**
to be used as a secondary unit or for smaller site applications. Equipped with two xCtrLine-4 cards and a basic xNET_mini card
- » **miniVES 4001N unit**
similar to the 4001 unit, additionally equipped with the xNET_mini-1Gb/WAN/RS card with extended networking capabilities
- » **miniVES 4001L unit**
primary system unit, equipped with an LCD screen and two xCtrLine-4 cards
- » **miniVES 4001LN unit**
similar to the 4001L unit with the addition of the xNET_mini-1Gb/WAN/RS card with extended networking capabilities
- » **miniVES 4002 unit**
to be used as a secondary unit or for smaller site applications. Equipped with four xCtrLine-2 cards and a basic xNET_mini card
- » **miniVES 4002N unit**
similar to the 4002 unit, additionally equipped with the xNET_mini-1Gb/WAN/RS card with extended networking capabilities
- » **miniVES 4002L unit**
primary system unit, equipped with an LCD screen and four xCtrLine-2 cards
- » **miniVES 4002LN unit**
similar to the 4002L unit with the addition of the xNET_mini-1Gb/WAN/RS card with extended networking capabilities
- » **miniVES 4002LNR**
Rack mounted unit (4u). Equipped with four xCtrLine-2 cards, fire microphone, LCD and xNET_mini-1Gb/WAN/RS card with extended networking capabilities
- » **DFMS Box unit**
unit containing the DFMS fireman's microphone as a standalone solution

midIVES system offers seven various control units:

- » **midIVES 8003R unit**
Rack mounted unit (4u) can be used as a secondary unit, requires rack minimum 15u for installation midIVES 8003R and batteries (4x 45 Ah / 12 V). Equipped with four xCtrLine-44 cards and a basic xNET_mini card
- » **midIVES 8003LNR unit**
Rack mounted unit (4u) can be used as a main unit with support of midIVES 8003R. Requires rack minimum 15u for installation with midIVES 8003R and batteries (4x 60 Ah / 12 V). Equipped with four xCtrLine-44 cards, fire microphone, LCD and xNET_mini-1Gb/WAN/RS card with extended networking capabilities.
- » **midIVES 8003LN unit**
Wall mounted unit. Equipped with four xCtrLine-44 cards, fire microphone, LCD and xNET_mini-1Gb/WAN/RS card with extended networking capabilities.

System elements operate with the following resolution: 48KHz/32 bits/2 channels. The communication between devices at large distances is carried out in 1000BASE-X technology (optical fibre), a thanks to 2 ports with SFP modules, connection redundancy occurs. In the case of connecting devices located in one RACK-type cabinet, it is advisable to use ports with RJ45 connectors. Available ports:

- » 1000BASE-TX / RJ45 – CAT5E cables – 2 ports available on the rear device panel/communication card,
- » 100BASE-TX / RJ45 – CAT5 cables – 1 port available on the rear panel responsible for connecting WAN external network, and PC with installed configuration software.

To create optical fibre connections, SFP modules are used. It creates a possibility of choosing optical fiber system elements independently and lower costs if the system does not use optical fiber connections.

Components of miniVES control unit:

- » 1 × main backplane
- » 2 × amplifier module
- » 1 × processor card with LAN/WAN 100 Mb/s connection
- » 1 × communication card (option)
- » optional GUI module
- » depending on version: 1 × CtrLine-4, 2 × CtrLine-4, 4 × CtrLine-2
- » 1 × Charger module

Components of midIVES control unit:

- » 1 × main backplane
- » 3 × amplifier module
- » 1 × processor card with LAN/WAN 100 Mb/s connection
- » 1 × communication card (option)
- » optional GUI module
- » 4 × CtrLine-44
- » 1 × Charger module

Components of DFMS Box unit:

- » 1 × main backplane
- » 1 × xNET_mini-1Gb/WAN/RS with 2 logical inputs and 2 logical outputs
- » 1 × Charger module

7.1.1.1 miniVES series 2001, 4001 and 4002 units

miniVES series 2001,4001 and 4002 units were designed to perform minor VAS system or serve as an extension unit in complex systems. In case of lack of connection with a superior unit, thanks to local configuration, it is able to carry out a fire scenario.

The device attached to the main system communication “ring” can receive alarm signals and digital signals and send them to other system devices.

The Control Unit’s main functions are:

- » Dividing audio signals into particular zones and overseeing proper operation of particular zones.
- » Controlling loudspeaker lines.
- » Detecting and signalling damage.
- » Activating internal back-up amplifier module.

Each unit is equipped with a built in communication card which provides one audio input and one audio output intended to connect amplifier inputs. Its diagram has been presented below.

Every central unit except the DFMS-BOX can work independently.

Line control card configuration:

- » **2001:** 1 × xCtrlLine-4
- » **4001:** 2 × xCtrlLine-4
- » **4002:** 4 × xCtrlLine-2

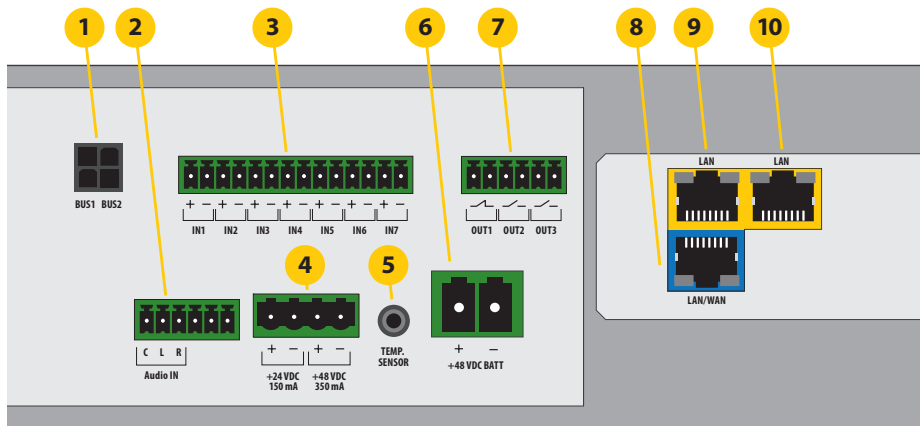

Drawing 1. Diagram of the connector panel for miniVES series 2001, 4001 and 4002 units

1. **Local audio bus outputs for 4 line control card operation**
2. **Audio input and output**
3. **Logic inputs**
4. **Auxillary power outputs**
5. **Battery temperature sensor input jack**
6. **Main Battery connector**
7. **Logic outputs**
8. **10/100 Mbps Lan/Wan port (PC connection)**
9. **10/100/1000 Mbps Lan port**
10. **10/100/1000 Mbps Lan port**

7.1.1.2 miniVES series 2001N, 4001N, 4002N

Units similar to the 2001, 4001, 4002 series with the exception of the extended xNET_mini-1Gb/WAN/RS network interface. This provides more connectivity and slots for two optional SFP modules.

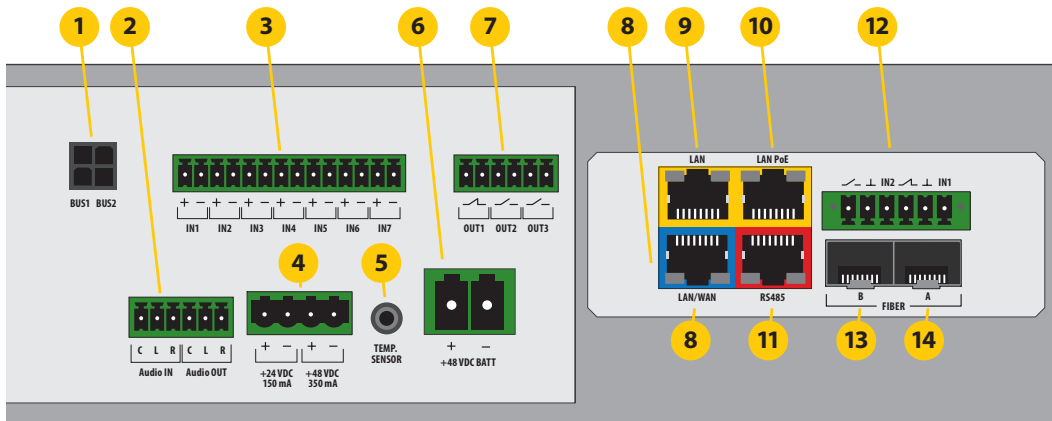

Drawing 2. Diagram of the connector panel for miniVES series 2001N, 4001N and 4002N units

1. **Local audio bus outputs for 4 line control card operation**
2. **Audio input and output**
3. **Logic inputs**
4. **Auxillary power outputs**
5. **Battery temperature sensor input jack**
6. **Main Battery connector**
7. **Logic outputs**
8. **10/100 Mbps Lan/Wan port (PC connection)**
9. **10/100/1000 Mbps Lan port**
10. **10/100/1000 Mbps Lan port**
11. **RS485 Port**
12. **Additional Logic I/O ports**
13. **SFP module slot B**
14. **SFP module slot A**

Table 1. miniVES series 2001, 4001, 4002 and series 2001N, 4001N, 4002N technical data

Model	miniVES 2001, 4001 and 4002	miniVES 2001N, 4001N, 4002N
Power supply	230 V AC, IEC C14 3pin terminal	
Power consumption	Up to 600 W (depending on configuration)	
Number of control slots	4	
Message storage	SD HC cards with capacities up to 32 GB supported The included 512 MB SLC SDHC card provides more than 20 min of message time	
LCD display	None	
DSP	Implemented 3 band parametric EQ	
Number of audio inputs	1	
Connector type	3 pin phoenix connector	
Frequency response	40 Hz... 20 kHz (@1 dB) / 400 Hz... 8 kHz (@0,1 dB)	
Input impedance	250 Ω	
Maximum input voltage	≤ 3 Vrms	
Nominal input voltage	775mV	
Number of outputs	1	
Type of outputs	Balanced	
Connector type	3 pin phoenix connector	
Frequency response	40 Hz... 20 kHz (@1dB) / 400 Hz... 8 kHz (@0,1dB)	
Harmonic distortion (THD+IMD)	≤ 0,05%	
Headroom	10 dB	
SNR	≥ 90 dB	
Output impedance	600 Ω	
Nominal output level	1 Vrms	
Data communication	Standard communication: <ul style="list-style-type: none"> › 1000BASE-TX/RJ45 CAT5E cables – 2 ports available on the connector panel › 100BASE-TX/RJ45 CAT5 cables – 1 port available on the connector panel, for connections with an external network 	Communication over large distances: <ul style="list-style-type: none"> › 1000BASE X optical fiber › 2 ports providing a redundant connection Standard communication: <ul style="list-style-type: none"> › 1000BASE-TX/RJ45 CAT5E cables – 2 ports available on the connector panel › 100BASE-TX/RJ45 CAT5 cables – 1 port available on the connector panel, for connections with an external network

Fiber module connector type / fiber type	SFP modules / SC/LC connector Multimode or single mode E30 or E90, OM or OM2
Communication with PC	PC software: RJ45, twisted pair connection TIA/EIA568-B via Ethernet protocol
Operating temperature	-5°C / +40°C
Operating humidity	15% to 80% (non-condensing)
Storage temperature	-20°C / +70°C
Storage Humidity	15% to 80% (non-condensing)
Case material and finish	Steel with powdercoat finish
Dimensions	439 (W) × 531 (H) × 355 (D) mm
Mount options	4 × 12 mm wall mount holes in the back of the case
Weight 2001	26 kg
Weight 4001	31 kg
Weight 4002	31,5 kg
Accessories	Battery cable, AC power connector, Handheld Microphone

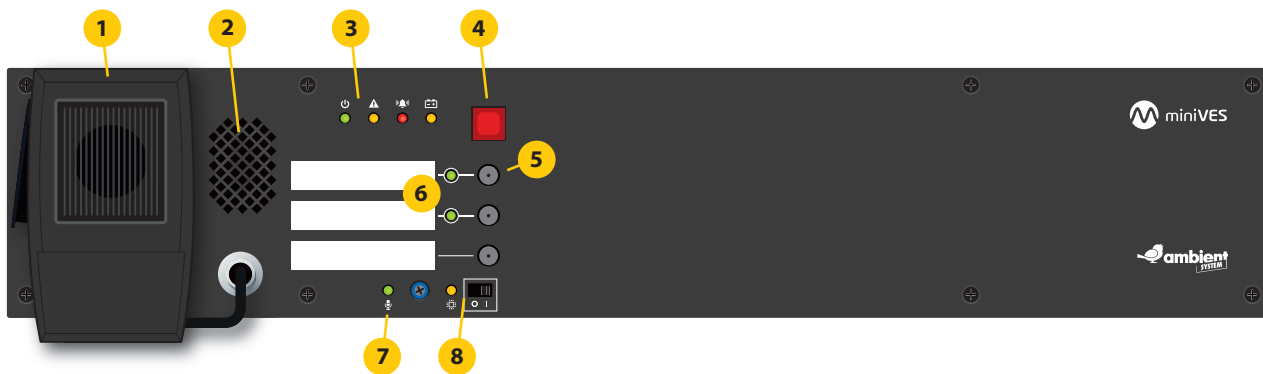

Drawing 3. Front panel of miniVES 2001, 4001, 4002 and 2001N, 4001N, 4002N series

1. **Handheld fireman's microphone**
2. **Built in speaker**
3. **Indicators**
 - a. power supply indicator (green LED)
 - b. Failure indicator (yellow LED)
 - c. Emergency indicator (red LED)
 - d. Battery power indicator (yellow LED)
4. **Emergency button**
5. **Configurable function buttons**
6. **Function button activation LEDs**
7. **Handheld microphone LED**

8. CPU off section

- a. CPU off function LED (yellow)
- b. CPU off function switch

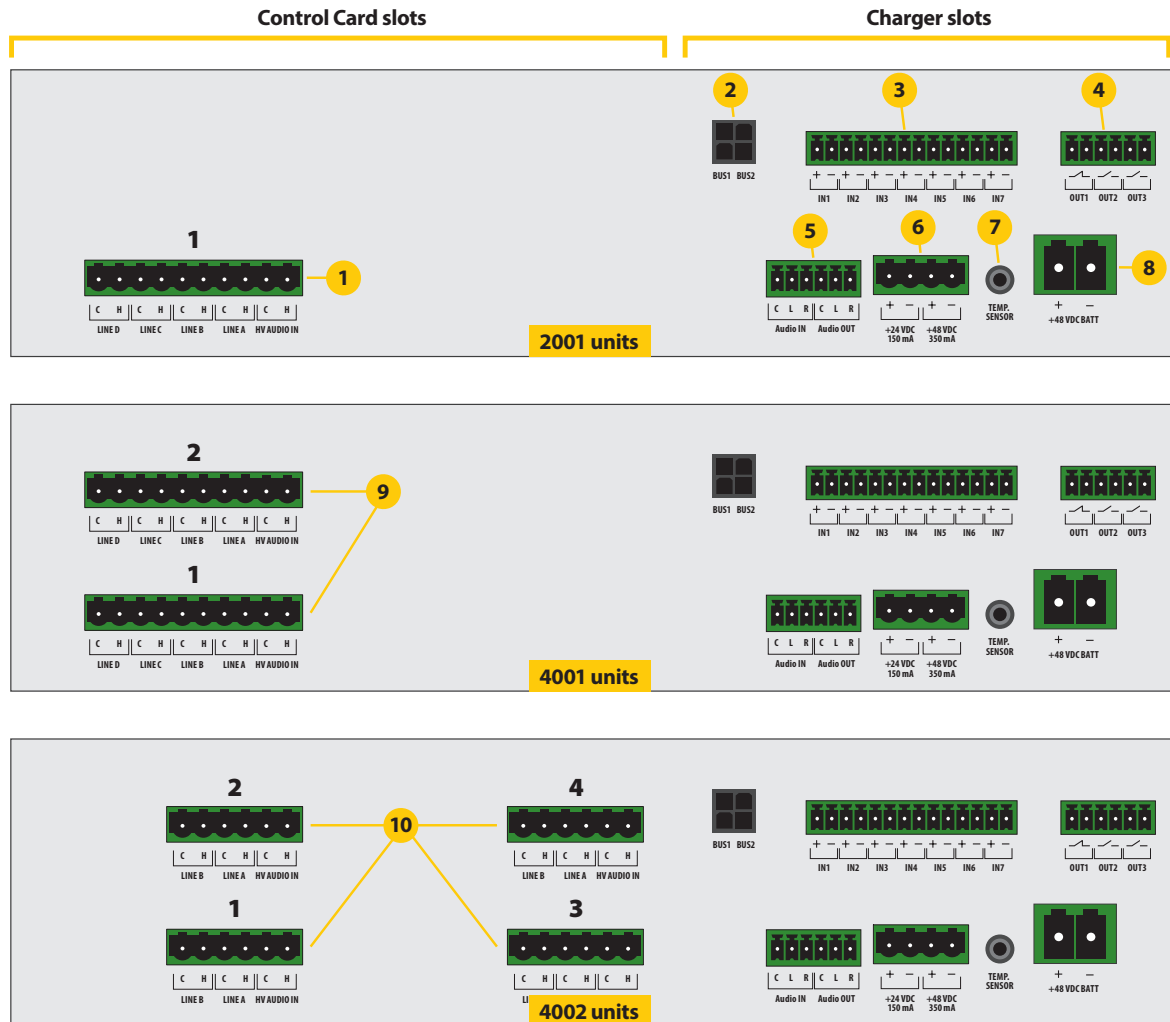

Drawing 4. Line control card arrangement for miniVES systems

1. **ABT-xCtrLine-4 control card**
2. **Local audio bus outputs for 4 line control card operation**
3. **Logic inputs connector**
4. **Logic outputs connector**
5. **Audio I/O connector**
6. **Auxillary power outputs**
7. **Temperature sensor input jack**
8. **Main battery connector**
9. **Two ABT-xCtrLine-4 control cards**
10. **Four ABT-xCtrLine-2 control cards**

Built in amplifier module options:

1. 200X series units use two 160W amplifier modules and a single switchable transformer. This enables one of the amplifiers to work as the main unit while the second one provides redundancy
2. 400X series units use two 320W amplifier modules with two transformers. This enables both of the amplifiers to work either simultaneously with the total output limited to 320W or with one used as main and the other one as backup.

7.1.1.3 miniVES series 2001L, 4001L and 4002L units

miniVES series 2001L, 4001L and 4002L units were designed to perform minor VAS system or serve as an extension unit in complex systems. In case of lack of connection with a superior unit, thanks to local configuration, it is able to carry out a fire scenario. The device attached to the main system communication "ring" can receive alarm signals and digital signals and send them to other system devices.

In comparison to previously presented 2001,4001, 4002 and 2001N, 4001N, 4002N series units these devices are equipped with a 4.5" touch screen LCD display which allows direct access to management and entire system monitoring functions.

The Control Unit's main functions are:

- » Dividing audio signals into particular zones and overseeing proper operation of particular zones.
- » Controlling loudspeaker lines.
- » Detecting and signalling damage.
- » Activating internal back-up amplifier module.
- » Each unit is equipped with a built in communication card which provides one audio input and one audio output intended to connect amplifier inputs. Its diagram has been presented below.

Every central unit except the DFMS-BOX can work independently.

Line control card configuration:

- » **2001L:** 1 × xCtrLine-4
- » **4001L:** 2 × xCtrLine-4
- » **4002L:** 4 × xCtrLine-2

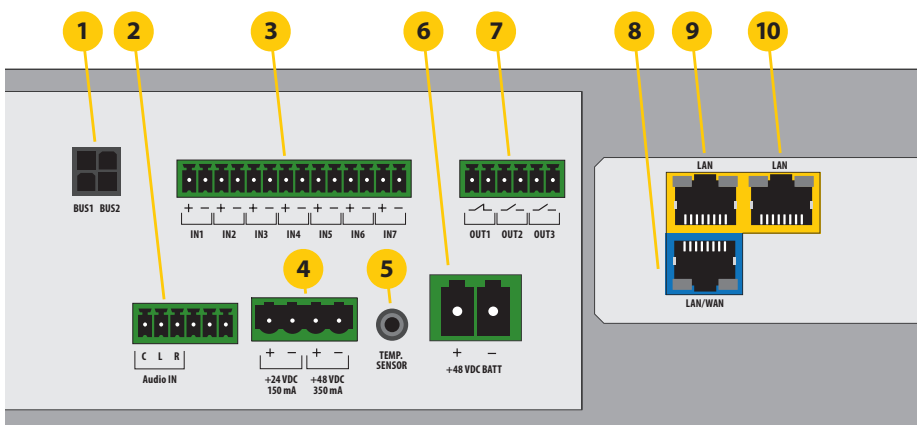

Drawing 5. Diagram of the connector panel for miniVES series 2001L, 4001L and 4002L units

1. **Local audio bus outputs for 4 line control card operation**
2. **Audio input and output**
3. **Logic inputs**
4. **Auxillary power outputs**

5. **Battery temperature sensor input jack**
6. **Main Battery connector**
7. **Logic outputs**
8. **10/100 Mbps Lan/Wan port (PC connection)**
9. **10/100/1000 Mbps Lan port**
10. **10/100/1000 Mbps Lan port**

7.1.1.4 miniVES series 2001LN, 4001LN, 4002LN

Units similar to the 2001L, 4001L, 4002L series with the exception of the extended xNET_mini-1Gb/WAN/RS network interface. This provides more connectivity and slots for two optional SFP modules.

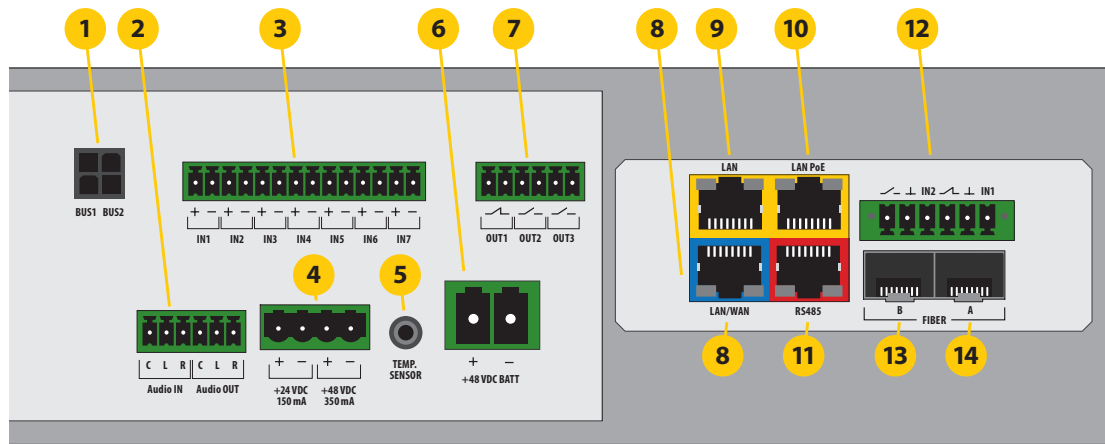

Drawing 6. *Diagram of the connector panel for miniVES series 2001LN, 4001LN and 4002LN units*

1. **Local audio bus outputs for 4 line control card operation**
2. **Audio input and output**
3. **Logic inputs**
4. **Auxillary power outputs**
5. **Battery temperature sensor input jack**
6. **Main Battery connector**
7. **Logic outputs**
8. **10/100 Mbps Lan/Wan port (PC connection)**
9. **10/100/1000 Mbps Lan port**
10. **10/100/1000 Mbps Lan port**
11. **RS485 Port**
12. **Additional Logic I/O ports**
13. **SFP module slot B**
14. **SFP module slot A**

Table 2. miniVES series 2001L, 4001L, 4002L and series 2001LN, 4001LN, 4002LN technical data

Model	miniVES 2001L, 4001L, 4002L	miniVES 2001LN, 4001LN, 4002LN, 4002LNR
Power supply	230 V AC, IEC C14 3pin terminal	
Power consumption	Up to 600 W (depending on configuration)	
Number of control slots	4	
Message storage	SD HC cards with capacities up to 32 GB supported The included 512 MB SLC SDHC card provides more than 20 min of message time	
LCD display	4,3" LCD touch screen	
DSP	Implemented 3 band parametric EQ	
Number of audio inputs	1	
Type of audio inputs	Unbalanced	
Connector type	3 pin phoenix connector	
Frequency response	40 Hz... 20 kHz (@1 dB) / 400 Hz... 8 kHz (@0,1 dB)	
Input impedance	250 Ω	
Maximum input voltage	≤ 3 Vrms	
Number of outputs	1	
Type of outputs	Balanced	
Connector type	3 pin phoenix connector	
Frequency response	40 Hz... 20 kHz (@1dB) / 400 Hz... 8 kHz (@0,1dB)	
Harmonic distortion (THD+IMD)	≤ 0,05%	
Headroom	10 dB	
SNR	≥ 90 dB	
Channel separation	≥ 80 dB	
Output impedance	600 Ω	
Nominal output level	1 Vrms	
Data communication	Standard communication: › 1000BASE-TX/RJ45 CAT5E cables – 2 ports available on the connector panel › 100BASE-TX/RJ45 CAT5 cables – 1 port available on the connector panel, for connections with an external network	Communication over large distances: › 1000BASE X optical fiber › 2 ports providing a redundant connection Standard communication: › 1000BASE-TX/RJ45 CAT5E cables – 2 ports available on the connector panel › 100BASE-TX/RJ45 CAT5 cables – 1 port available on the connector panel, for connections with an external network
Fibre module connector type / fibre type	SFP modules / SC/LC connector Multimode or single mode E30 or E90, OM or OM2	
Communication with PC	PC software: RJ45, twisted pair connection TIA/EIA568-B via Ethernet protocol	

Operating temperature	-5°C / +40°C
Operating humidity	15% to 80% (non-condensing)
Storage temperature	-20°C / +70°C
Storage humidity	15% to 80% (non-condensing)
Case material and finish	Steel with powdercoat finish
Dimensions	439 (W) × 176 (H) × 354 (D) mm for 4002LNR
Mount options	4 × 10 mm wall mount holes in the back of the case
Weight	24 kg
Accessories	Battery cable, AC power connector, Handheld Microphone

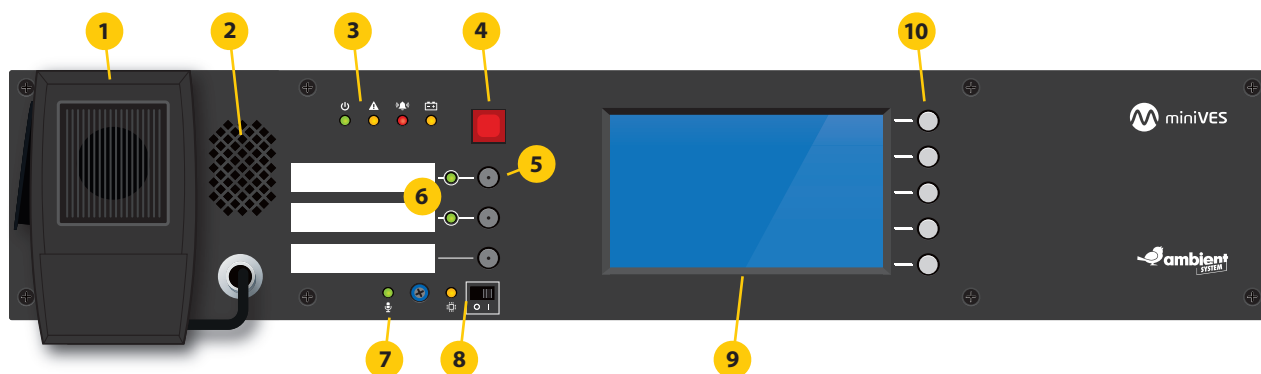

Drawing 7. Front panel of miniVES 2001L, 4001L, 4002L and 2001LN, 4001LN, 4002LN, 4002LNR series

1. **Handheld fireman's microphone**
2. **Built in speaker**
3. **Indicators**
 - a. Power supply indicator (green LED)
 - b. Failure indicator (yellow LED)
 - c. Emergency indicator (red LED)
 - d. Battery power indicator (yellow LED)
4. **Emergency button**
5. **Configurable function buttons**
6. **Function button activation LEDs**
7. **Handheld microphone LED**
8. **CPU off section**
 - a. CPU off function LED (yellow)
 - b. CPU off function switch
9. **Display – shows control unit's menu**
10. **Functional keys, support auxillary functions when navigating the menu**
 - a. HOME – press to return to the fers menu
 - b. ENTER – press to enter value/select control unit in menu
 - c. Up arrow – press to navigate in the control unit menu
 - d. Down arrow – press to navigate in the control unit menu
 - e. Back – press to return to previous item in the control unit menu

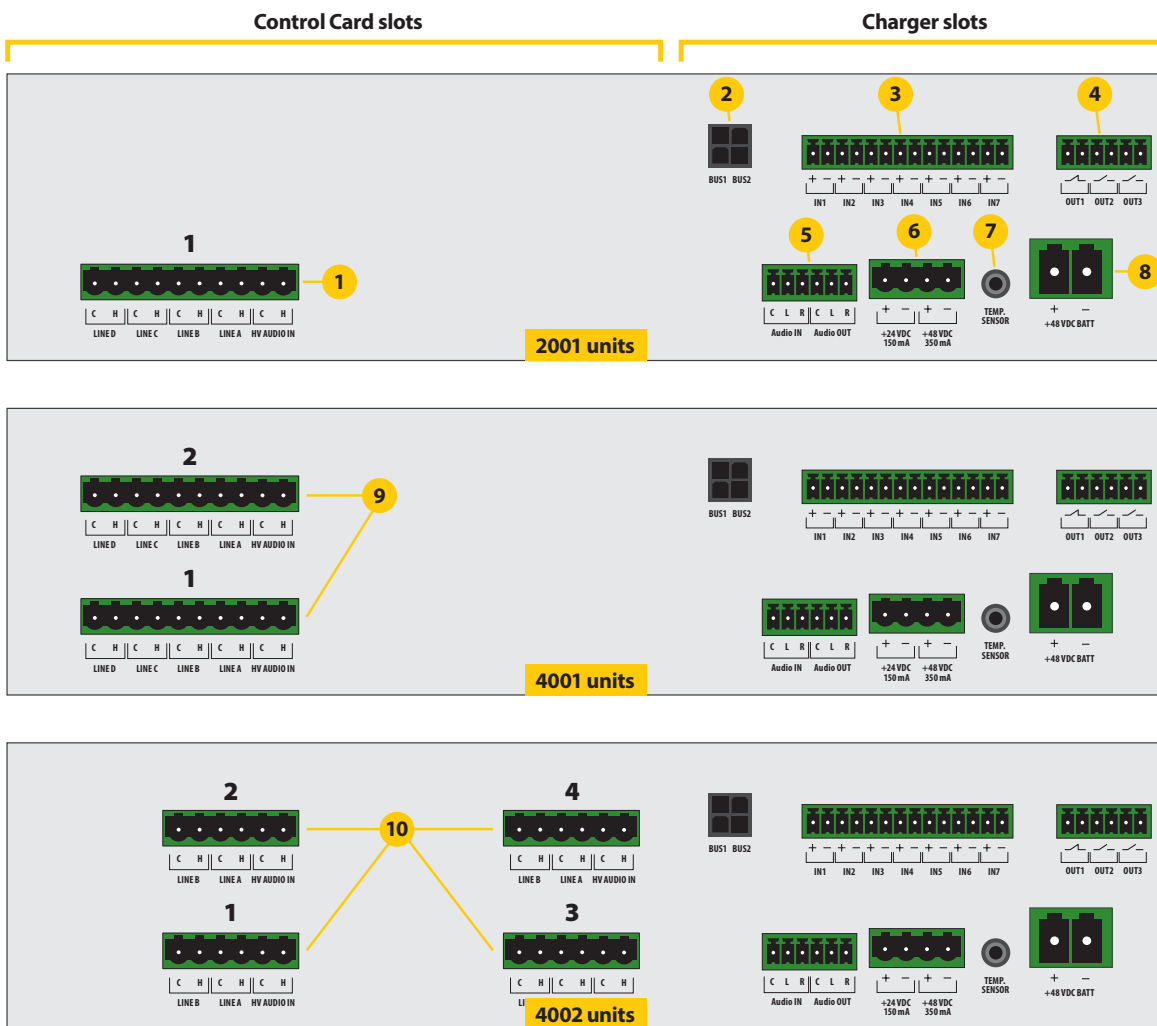

Drawing 8. Line control card arrangement for miniVES systems

1. **ABT-xCtrLine-4 control card**
2. **Local audio bus outputs for 4 line control card operation**
3. **Logic inputs connector**
4. **Logic outputs connector**
5. **Audio I/O connector**
6. **Auxillary power outputs**
7. **Temperature sensor input jack**
8. **Main battery connector**
9. **Two ABT-xCtrLine-4 control cards**
10. **Four ABT-xCtrLine-2 control cards**

7.1.1.5 midIVES 8003R unit

midIVES 8003R units were designed to perform minor VAS system or serve as an extension unit in complex systems. In case of lack of connection with a superior unit, thanks to local configuration, it is able to carry out a fire scenario. The device attached to the main system network can receive alarm signals and digital signals and send them to other system devices.

The Control Unit's main functions are:

- » Dividing audio signals into particular zones and overseeing proper operation of particular zones.
- » Controlling loudspeaker lines.
- » Detecting and signalling damage.
- » Sctivating internal back-up amplifier module.

Each unit is equipped with a built in communication card which provides one audio input and one audio output intended to connect amplifier inputs. Its diagram has been presented below.

Every central unit except the DFMS-BOX can work independently.



Drawing 9. *midIVES 8003R unit*

Line control card configuration:

» **8003R** (rack mounted version): 4 × xCtrLine-44

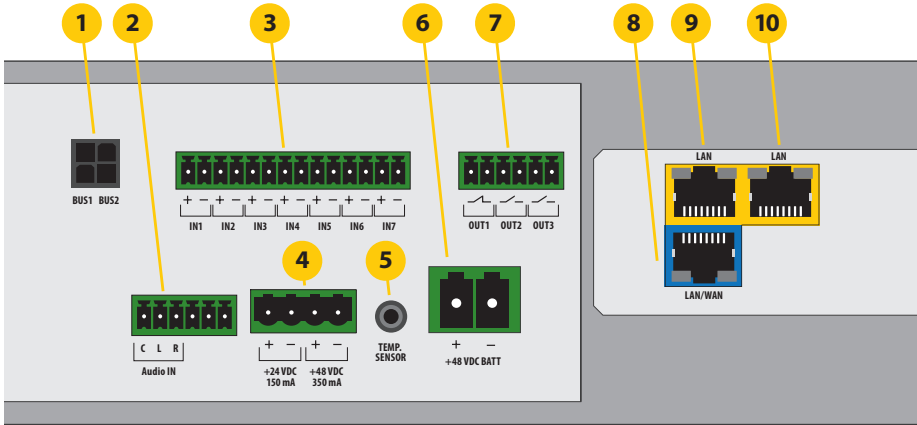

Drawing 10. Diagram of the connector panel for midiVES 8003R unit

1. **Local audio bus outputs for 4 line control card operation**
2. **Audio input**
3. **Logic inputs**
4. **Auxillary power outputs +24 DC, +48 DC**
5. **Battery temperature sensor input jack**
6. **Main Battery connector**
7. **Logic outputs**
8. **10/100 Mbps Lan/Wan port (PC connection)**
9. **10/100/1000 Mbps Lan port**
10. **10/100/1000 Mbps Lan por**

Table 3. midiVES 8003R technical data

Model	midiVES 8003R
Power supply	230 V AC, IEC C14 3pin terminal
Power consumption	Up to 1600 W (depending on configuration)
Number of control slots	4
Message storage	SD HC cards with capacities up to 32 GB supported The included 512 MB SLC SDHC card provides more than 20 min of message time
LCD display	None
DSP	Input EQ, outputs EQ, Feedback eliminator and audio limiter, delay up to 30000 ms
Number of audio inputs	1
No of speaker lines	16

No of control inputs	7
Control by	Programmable 4 buttons and color touch screen
No of relay outputs	3
No of messages played at the same time	3
Connector type	3 pin phoenix connector
Frequency response	20 Hz - 22kHz (+0,5 / -3dB) Rated power
Input impedance	250 Ω
Maximum input voltage	≤ 3 Vrms
Rated output voltage	100Vrms / 20 Ω , THD+N < 1%
Total Harmonic Distortion + Noise (THD+N)	< 0,1%
Signal to Noise Ratio (SNR)	> 76dB
Data communication	Standard communication: › 1000BASE-TX/RJ45 CAT5E cables – 2 ports available on the connector panel › 100BASE-TX/RJ45 CAT5 cables – 1 port available on the connector panel, for connections with an external network
Communication with PC	PC software: RJ45, twisted pair connection TIA/EIA568-B via Ethernet protocol
Operating temperature	-5°C / +40°C
Operating humidity	15% to 80% (non-condensing)
Storage temperature	-20°C / +70°C
Storage humidity	15% to 80% (non-condensing)
Case material and finish	Steel with powdercoat finish
Dimensions	439 (W) \times 176 (H) \times 354 (D) mm
Finish	Black
Mounting method	19" rack or desk top
Ingress protection	IP30
Weight	15 kg
Accessories	Battery cable, AC power connector, Handheld Microphone
Protection	Over-temperature, short circuit, overload, ground leakage

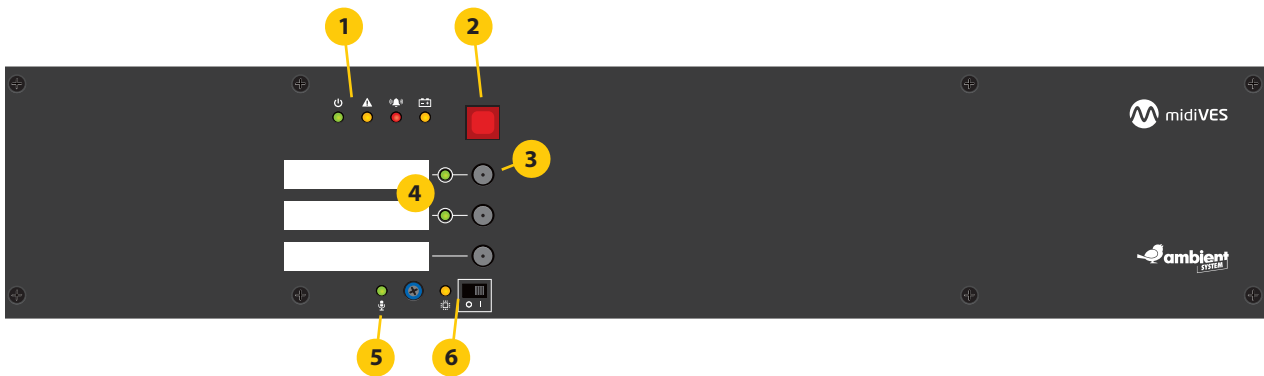

Drawing 11. Front panel of midiVES 8003R

1. **Indicators**

- a. Power supply indicator (green LED)
- b. Failure indicator (yellow LED)
- c. Emergency indicator (red LED)
- d. Battery power indicator (yellow LED)

2. **Emergency button**

3. **Configurable function buttons**

4. **Function button activation LEDs**

5. **Handheld microphone LED**

6. **CPU off section**

- a. CPU off function LED (yellow)
- b. CPU off function switch

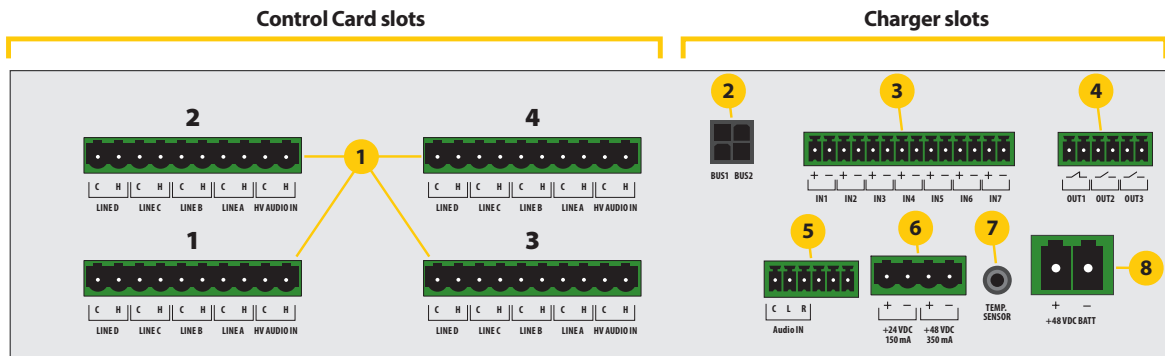

Drawing 12. Line control card arrangement for midiVES 8003R

1. **Four ABT-xCtrLine-44 control cards**
2. **Local audio bus outputs for 4 line control card operation**
3. **Logic inputs connector**
4. **Logic outputs connector**
5. **Audio IN connector**
6. **Auxillary power outputs**
7. **Temperature sensor input jack**
8. **Main battery connector**

Built in amplifier module options:

8003R s unit uses three 500 W Class D transformerless amplifiers. This enables three of the amplifiers to work simultaneously with the total audio load up to 1500 W.

7.1.1.6 *midIVES series 8003LN, 8003LNR units*

midIVES 8003LN and 8003LNR units are the main PAVA centrals. Units consists 4,3" touch screen for ease of control and fault finding as well as fire microphone and extended network card with 2xSFP, 1xPOE and additional 2x logical input and outputs.

The difference between units is in type of chasis. midIVES 8003 LN is wall mounted 12RU standalone box while 8003LNR is rack mounted 4RU device. 8003LNR can be connected with 8003R sharing the same set of 4x12V batteries and mount them to te single minimum 15RU rack.



Drawing 13. *midIVES 8003LR / 8003LNR*

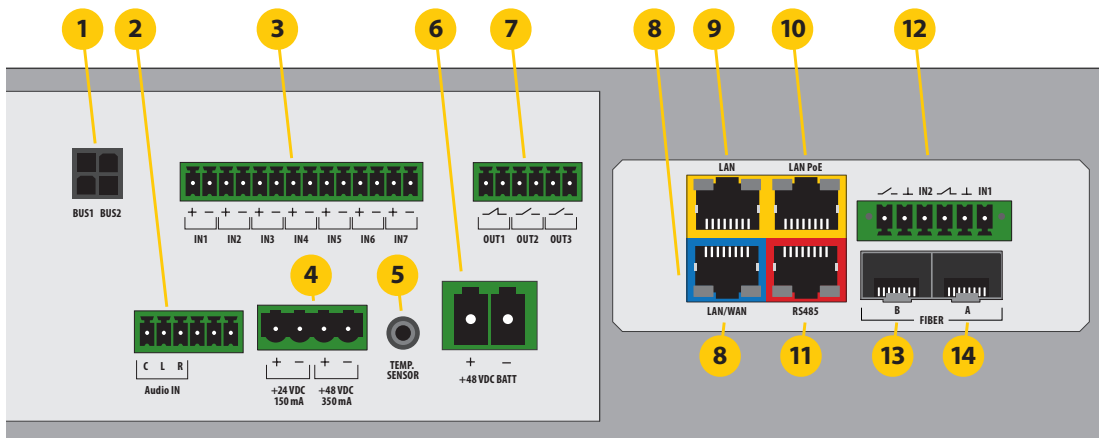

Drawing 14. *Diagram of the connector panel for midIVES series 8003LN, 8003LNR units*

1. **Local audio bus outputs for 4 line control card operation**
2. **Audio input**

3. **Logic inputs**
4. **Auxillary power outputs**
5. **Battery temperature sensor input jack**
6. **Main battery connector**
7. **Logic outputs**
8. **10/100 Mbps Lan/Wan port (PC connection)**
9. **10/100/1000 Mbps Lan port**
10. **10/100/1000 Mbps Lan port**
11. **RS485 Port**
12. **Additional Logic I/O ports**
13. **SFP module slot B**
14. **SFP module slot A**

 Table 4. *midIVES series 8003LN, 8003LNR technical data*

Model	midIVES 8003LNR	midIVES 8003LN
Power supply	230 V AC, IEC C14 3pin terminal	
Power consumption	Up to 1600 W (depending on configuration)	
Number of control slots	4	
Message storage	SD HC cards with capacities up to 32 GB supported The included 512 MB SLC SDHC card provides more than 20 min of message time	
LCD display	4,3" LCD touch screen	
DSP	Input EQ, outputs EQ, Feedback eliminator and audio limiter, delay up to 30000 ms	
Number of audio inputs	1	
No of speaker lines	16	
No of control inputs	7	
Control by	Programmable 4 buttons and color touch screen	
No of relay outputs	1x NC, 2x NO	
Switching current (Max.)	1 A peak *	
Switching voltage (Max.)	50 V AC/DC peak *	
Switching power (Max.)	30 W *	
No of messages played at the same time	3	
Connector type	3 pin phoenix connector	
Frequency response	20 Hz - 22kHz (+0,5 / -3dB) Rated power	
Input impedance	250 Ω	

Maximum input voltage	≤ 3 Vrms	
Rated output voltage	100Vrms / 20 Ω, THD+N < 1%	
Total Harmonic Distortion + Noise (THD+N)	< 0,1%	
Signal to Noise Ratio (SNR)	> 76dB	
Data communication	2 × SFP module 1 Gb/s, 1 × POE 1 Gb/s, 100 Mb/s, 1 × LAN 1 Gb/s, 100 Mb/s connection; RS485 port; 1 × LAN/WAN 100 Mb/s connection	
Fiber module connector type / fibre type	SFP modules / SC/LC connector Multimode or single mode E30 or E90, OM or OM2	
Communication with PC	PC software: RJ45, twisted pair connection TIA/EIA568-B via Ethernet protocol	
Operating temperature	-5°C / +40°C	
Operating humidity	15% to 80% (non-condensing)	
Storage temperature	-20°C / +70°C	
Storage humidity	15% to 80% (non-condensing)	
Case material and finish	Steel with powder coat finish	
Dimensions	439 (W) × 176 (H) × 354 (D) mm	439 (W) × 525 (H) × 350 (D) mm
Finish	Black	
Mounting method	19" rack or desk top	
Ingress protection	IP30	
Weight	15 kg	20 kg
Accessories	Battery cable, AC power connector, Handheld Microphone	
Protection	Over-temperature, short circuit, overload, ground leakage	

⚠ IMPORTANT!

Any DC combination of V & A not to exceed switching power max value. Not allowed capacitive nor inductive load, because of large inrush current / voltage spike, that can significantly exceed the maximum allowed switching current or voltage.

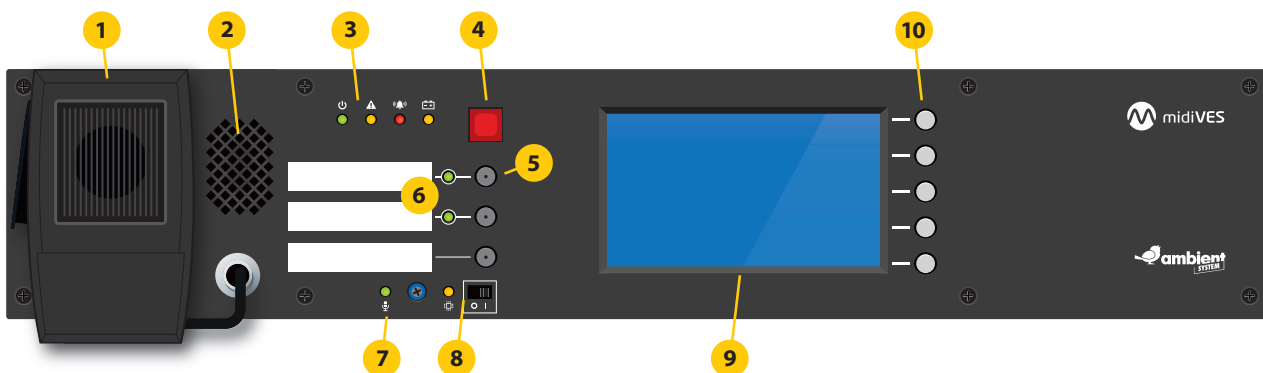

Drawing 15. Front panel of midiVES 8003LN and 8003LNR series

1. **Handheld fireman's microphone**
2. **Built in speaker**
3. **Indicators**
 - a. Power supply indicator (green LED)
 - b. Failure indicator (yellow LED)
 - c. Emergency indicator (red LED)
 - d. Battery power indicator (yellow LED)
4. **Emergency button**
5. **Configurable function buttons**
6. **Function button activation LEDs**
7. **Handheld microphone LED**
8. **CPU off section**
 - a. CPU off function LED (yellow)
 - b. CPU off function switch
9. **Display – shows control unit's menu**
10. **Functional keys, support auxillary functions when navigating the menu**
 - a. HOME – press to return to the fers menu
 - b. ENTER – press to enter value/ select control unit in menu
 - c. Up arrow – press to navigate in the control unit menu
 - d. Down arrow – press to navigate in the control unit menu
 - e. Back – press to return to previous item in the control unit menu

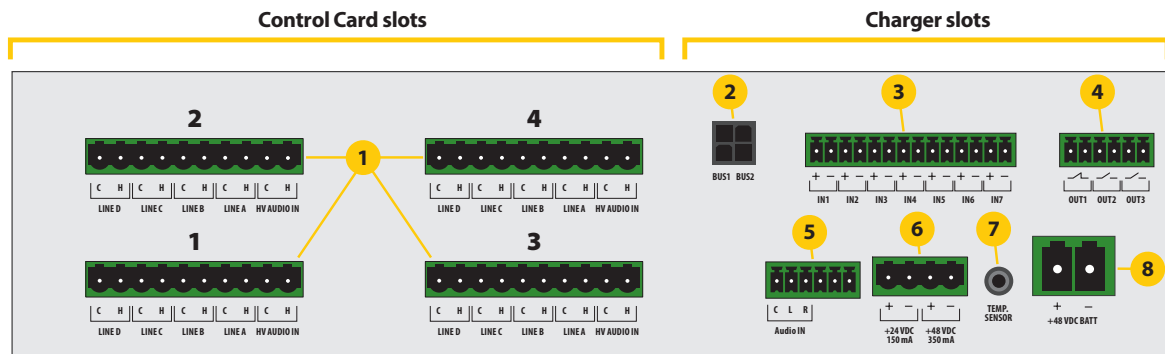

Drawing 16. Line control card arrangement for midiVES 8003LN, 8003LNR series

1. **ABT-xCtrLine-44 control card x 4**
2. **Local audio bus outputs for 4 line control card operation**
3. **Logic inputs connector**
4. **Logic outputs connector**
5. **Audio IN connector**
6. **Auxillary power outputs**
7. **Temperature sensor input jack**
8. **Main battery connector**

7.1.1.7 DFMS Box

This unit is a fusion of the Fireman microphone and miniVES Chassis. It features the same functionality as the fireman microphone with the addition of emergency battery power. In comparison to the previously presented miniVES units the DFMS Box lacks amplifier modules and line control cards.

7.1.2 Extension cards

Every individual element of the system has a set of functions related to sending audio signal, system operation (operation or event reporting), as well as auto-diagnostics.

7.1.2.1 ABT-xNET_mini-1Gb/WAN/RS communication card

ABT-xNET_mini-1Gb/WAN/RS is a communication card consisting of two independent 1 Gbit network switches. The network switch no.1 is intended solely to transmit data related to basic miniVES system functions, that is performing tasks of alarm voice system and AVB support. The network switch no. 2 is intended for remote connections. The card supports TCP/UDP/PTP/DHCP protocols and assures audio data exchange in CPU-OFF mode via an innovative Ambient System protocol. Additionally, this card is equipped with RS485 port which implements and integrates miniVES with any system, e.g. SAP. Another advantage is support of PoE technology to power, e.g. fireman microphone.



Drawing 17. *ABT-xNET_mini-1Gb/WAN/RS communication card*

Unlike the MULTIVES system in the miniVES / midiVES devices the communication card also doubles as the main CPU card. It is responsible for reproducing audio messages from the SD card and sharing them locally or globally while also performing system and control functions.

The card is capable of reproducing 8 messages at a time and supports SD cards up to 32 GB for individual messages, as well as event or defect logs or system update files.

The communication card:

- » has two switches (2 LAN 10/100/1000 ports), system (for VAS communication) and for remote connections (disconnected during fire-fighting) (1 LAN/WAN 10/100 port – configurable working mode),
- » is equipped with VAS switch with AVB support,
- » allows 1Gb/s transmission speed and has optical-fiber interface (2 connectors for SFP modules),
- » supports TCP/UDP/PTP/DHCP protocols,
- » assigns IP addresses dynamically,
- » has PoE feature,
- » can support two logic inputs or two relay outputs (every channels is configured on a case-by-case basis, and by default, both are set as logic inputs) relay outputs NC/NO,
- » in CPU-OFF mode. It transmits audio data via independent protocol,
- » in the future it will allow using network infrastructure for other Audio-Video purposes.

To connect communication cards and fireman microphone via an optical cable, it is required to use highly-reliable low power consumption SFP 1,25 Gbps optical modules.

SFP modules operate with single or multiple-mode optical fibers sending information with up to 1,25 Gbps. They transmit data through optical fiber pairs (duplex). Both SC and LC connectors can be used, the unit also supports digital optical monitoring (DOM).

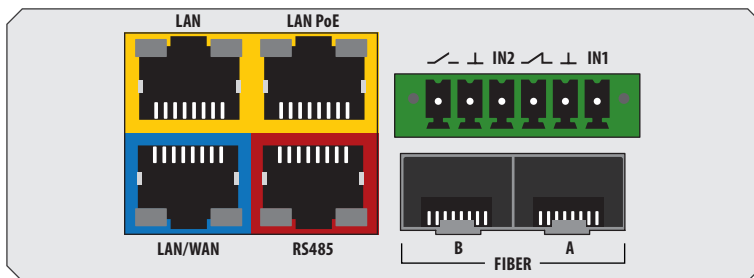

Drawing 18. ABT-xNET_mini-1Gb/WAN/RS communication card

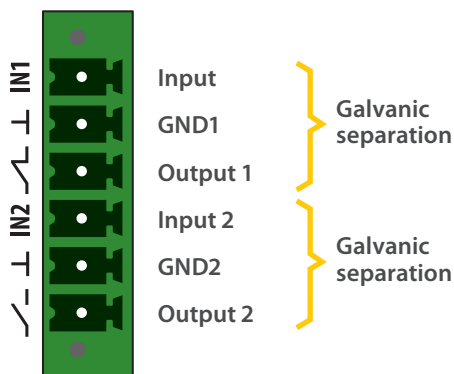

Drawing 19. Diagram of logical inputs/outputs of communication card

Table 5. Technical parameters of ABT-xNET_mini-1Gb/WAN/RS communication card

Model	ABT-xNET-1Gb/WAN/RS
Source of power	Control Unit main backplane or main-passive
Power consumption	48 V about 100 mA; Input/output/PoE extension – max. consumption 360 mA, Typical consumption depends on devices connected to the card via RJ45 connector (PoE) max. 15 W
Optical module – type of connector	SFC modules, SC/LC connector, Multi-mode or single-mode optical fibre, E 30 or E 90, OM1, OM2, OM3
Number of logical inputs / outputs	2 independent channels; galvanically separated 1 × NO, 1 × NC output
Switching current (Max.)	1 A peak *
Switching voltage (Max.)	50 V AC/DC peak *
Switching power (Max.)	30 W *
Source of parametric input signal	Passive, standard resistors: 4 kΩ ↔ 10 kΩ, detection thresholds 0/1/short-circuit/open-circuit set in configuration application
Type of logic input / output seats	Screw terminals PHOENIX 6 pin-type, 3,5 mm
PoE output voltage, load capacity	48 V, 0,3 A of load capacity
Number of RS485 connectors	1 in RJ45
Max. length of RS485 cable	1200 m (according to specifications and characteristics RS485)
Operating temperature	-5°C to +40°C
Operating humidity	15% to 80% (without condensation)
Storage temperature	-20°C to +70°C
Storage humidity	15% to 80% (without condensation)
Dimensions	70 × 160 × 30 (mm)

▲ IMPORTANT!

Any DC combination of V & A not to exceed switching power max value. Not allowed capacitive nor inductive load, because of large inrush current / voltage spike, that can significantly exceed the maximum allowed switching current or voltage.

7.1.2.2 ABT-xNET_mini-1Gb communication card

The ABT-xNET_mini-1Gb is a downsized version of the previous ABT-xNET_mini-1Gb/WAN/RS communication card. As it's predecessor it consists of two independent 1 Gbit network switches.

The network switch no.1 is intended solely to transmit data related to basic miniVES system functions, that is performing tasks of alarm voice system.

The network switch no. 2 is intended for remote connections. The card supports TCP/UDP/PTP/DHCP protocols and assures audio data exchange in CPU-OFF mode via an innovative Ambient System protocol. This card is not equipped with an RS485 port, POE, SFP ports and logical inputs and outputs.

Unlike the MULTIVES system in the miniVES / midiVES devices the communication card also doubles as the main CPU card. It is responsible for reproducing audio messages from the SD card and sharing them locally or globally while also performing system and control functions.

The card is capable of reproducing 8 messages at a time and supports SD cards up to 32 GB for individual messages, as well as event or defect logs or system update files.

The communication card:

- » has two switches (2 LAN 10/100/1000 ports), system (for VAS communication) and for remote connections (disconnected during fire-fighting) (1 LAN/WAN 10/100 port – configurable working mode),
- » is equipped with VAS switch with AVB support,
- » supports TCP/UDP/PTP/DHCP protocols,
- » assigns IP addresses dynamically,
- » in CPU-OFF mode. It transmits audio data via independent protocol,

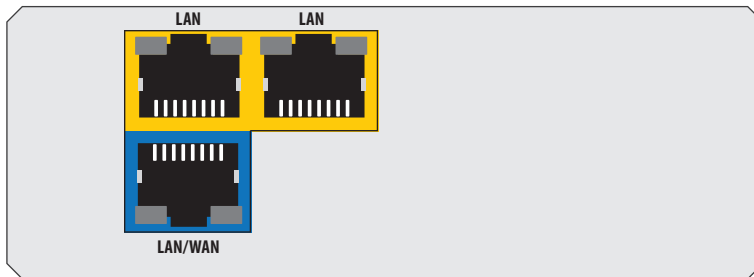

Drawing 20. ABT-xNET_mini-1Gb communication card

Table 6. Technical parameters of ABT-xNET_mini-1Gb communication card

Model	ABT-xNET_mini-1Gb
Source of power	Control Unit main backplane
Power consumption	48 V about 100 mA; Input/output/PoE extension – max. consumption 360 mA, Typical consumption depends on devices connected to the card via RJ45 connector (PoE) max. 15 W
Optical module – type of connector	none
Number of logical inputs/outputs	none
Source of parametric input signal	Does not apply
Type of logic input/output seats	Does not apply
PoE output voltage, load capacity	48 V, 0,3 A of load capacity
Number of RS485 connectors	none
Max. length of RS485 cable	Does not apply

Working temperature	-5°C to +40°C
Ambient humidity during operation	from 15% to 80% (without condensation)
Storage temperature	-20°C to +70°C
Ambient humidity during storage	from 15% to 80% (without condensation)
Dimensions	70 × 160 × 30 (mm)

7.1.2.3 ABT-xCtrLine-4 – Control card of 4 loudspeaker lines

ABT-xCtrLine-4 card provides 4 independent outputs of loudspeaker lines (A,B,C,D).

The card relays 100 V signal to loudspeaker lines from individual HV audio input placed on the card's front panel or the internal 100 V bus available for all control cards.

The card allows switching between main and back-up amplifier modules.

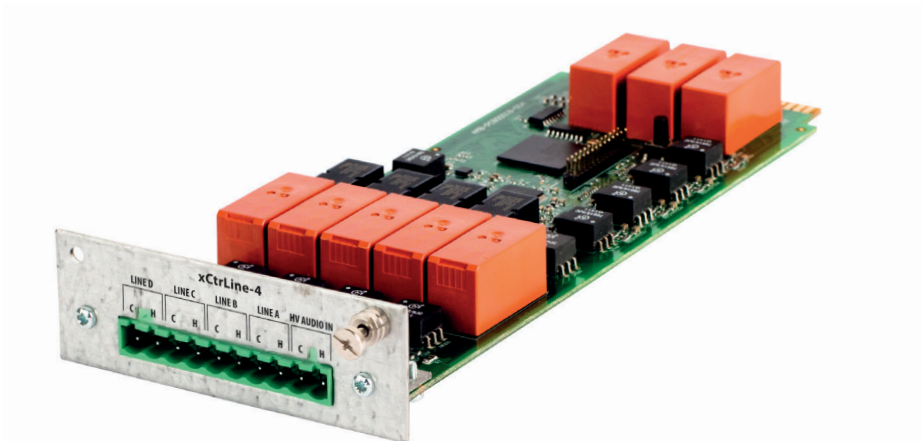

Drawing 21. ABT-xCtrLine-4 loudspeaker lines control card

Line measurements can be performed by means of two various methods:

- » impedance,
- » loop.

The card detects short-circuit, open-circuit and absence of elements.

⚠ Maximum power which ABT-xCtrLine-4 can handle is 800 W for 100 V line. Each output on the card can handle up to 300 W (100 V Line), in the parallel connection of the A-B, C-D maximum load is 450 W.

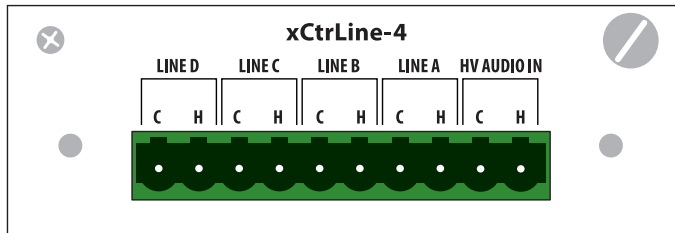

Drawing 22. ABT-xCtrLine-4 loudspeaker lines control card

Table 7. Technical data of ABT-xCtrLine-4

Model	ABT-xCtrLine-4
Power supply	Internal from the Control Unit backplane
Maximum current consumption	152 mA for 48 V
Type of connector	10 pin screw terminal type PHOENIX, 5.08 mm
Impedance measurement frequency	1 kHz to 48 kHz
Frequency of the signal for EOL modules	18 kHz to 24 kHz
Maximum measured current	20 A
Maximum measured voltage	200 V
Accuracy of measurement	Up to 5%
Operating temperature	-5°C to 40°C
Operating Humidity	15% to 80%
Storage Temperature	-20°C to 70°C (non-condensing)
Storage Humidity	5% to 95% (non-condensing)
Dimensions	70 × 215 × 30 (mm)
Accessories	Screw terminals 10 pins, the distance between the partitions 5.08 mm

7.1.2.4 ABT-xCtrLine-2 – 2 loudspeaker lines control card

ABT-xCtrLine-2 card provides 2 independent loudspeaker line outputs (A,B).lcd

The card relays of 100 V signal to loudspeaker lines from individual HV audio input located on the card's front panel or from the internal 100 V bus available to all control cards.

The card allows switching between main and back-up amplifier modules.

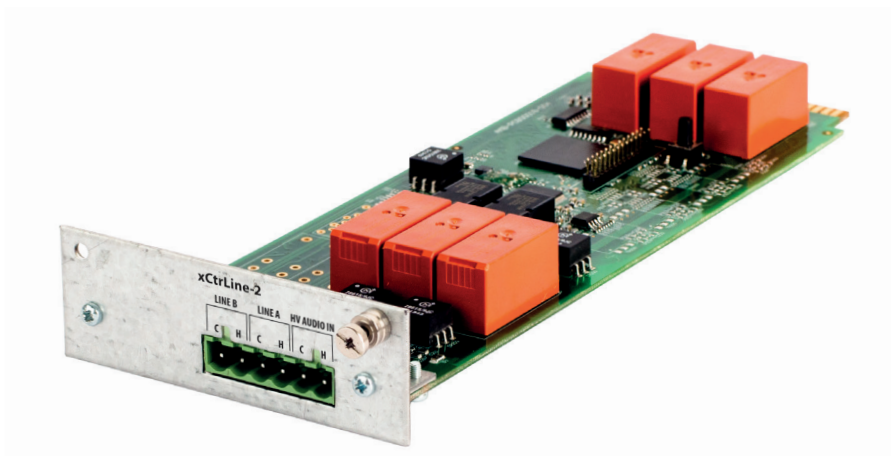

Drawing 23. ABT-xCtrLine-2 card model

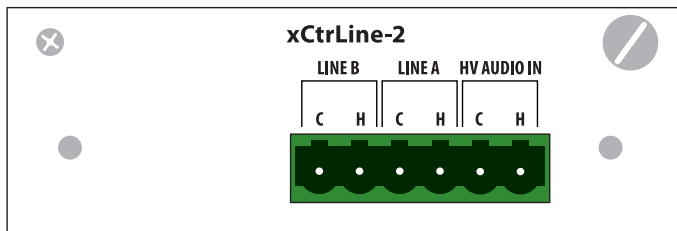

Drawing 24. ABT-xCtrLine-2 card model

Line measurements can be performed by means of two various methods:

- » impedance,
- » loop.

The card detects short-circuit, open-circuit and absence of elements.

⚠ Maximum power which ABT-xCtrLine-2 can handle is 600 W for 100 V line. Each output on the card can handle up to 300 W (100 V Line), in the parallel connection of the A-B, C-D maximum load is 450 W.

Table 8. Technical data of ABT-xCtrLine-2

Model	ABT-xCtrLine-2
Power supply	Internal from the Control Unit backplane
Maximum current consumption	121 mA for 48 V
Type of connector	6 pin screw terminal type PHOENIX, 5.08 mm
Impedance measurement frequency	1 kHz to 48 kHz
Frequency of the signal for EOL modules	18 kHz to 24 kHz
Maximum measured current	20 A
Maximum measured voltage	200 V
Accuracy of measurement	Up to 5%
Operating temperature	-5°C to 40°C
Operating Humidity	15% to 80%
Storage Temperature	-20°C to 70°C (non-condensing)
Storage Humidity	5% to 95% (non-condensing)
Dimensions	70 × 215 × 30 (mm)
Accessories	Screw terminals 6 pins, the distance between the partitions 5.08 mm

Connecting loudspeaker lines illustrated with an example of xCtrLine-2 card

You can connect loudspeaker lines by means of 3 methods: impedance, loop and ABT-EOL end-of-line module.

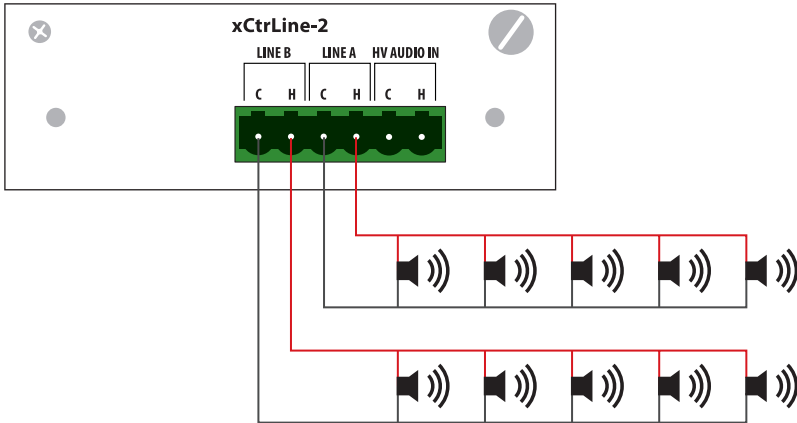

Drawing 25. Impedance connection

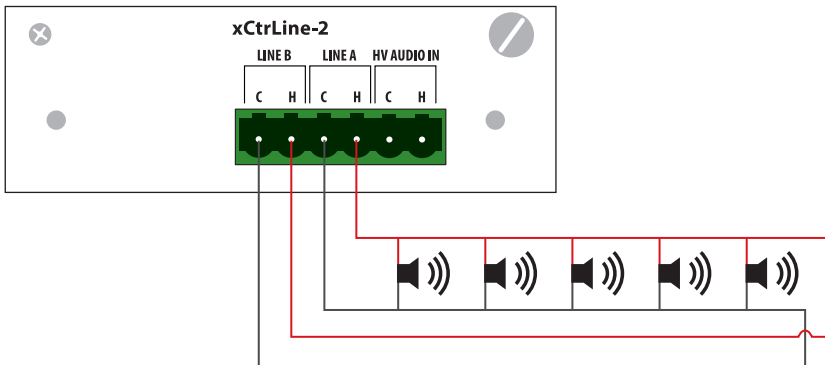

Drawing 26. Loop connection

7.1.2.5 ABT-xCtrLine-44 – Control card of 4 loudspeaker lines

ABT-xCtrLine-44 card provides 4 independent outputs of loudspeaker lines (A,B,C,D) with routing possibilities of 5 signals (4 × 100 V Bus, 1x high voltage individual input). Each of the line (A, B, C, D) can play different message at the same time.

The card allows switching between main and back-up amplifier modules.

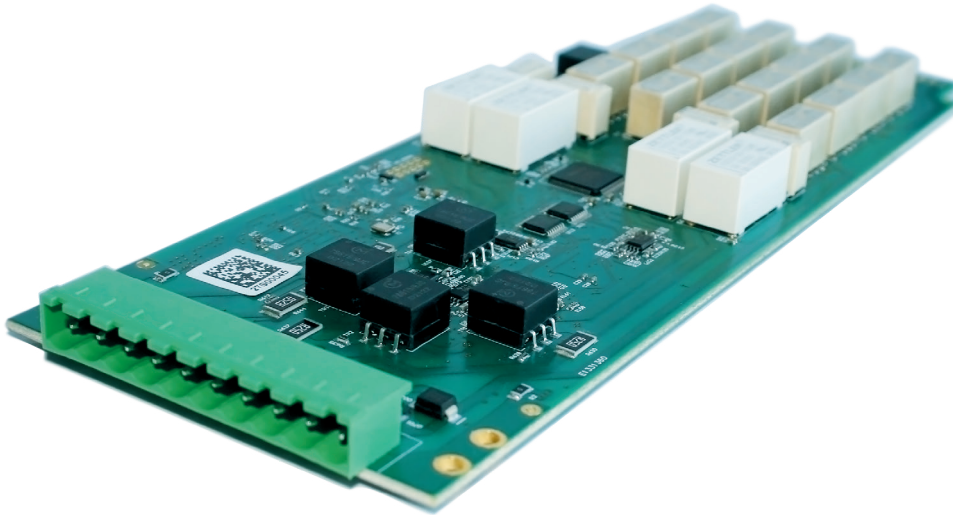

Drawing 27. ABT-xCtrLine-44 loudspeaker lines control card

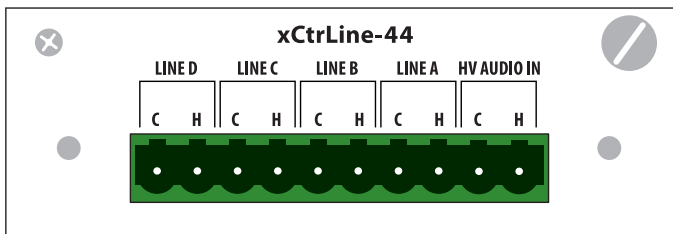

Drawing 28. ABT-xCtrLine-44 loudspeaker lines control card

Line measurements can be performed by means of three various methods:

- » impedance,
- » loop with short isolators,
- » EOL .

The card detects short-circuit, open-circuit and absence of elements.

- ⚠** Maximum power which ABT-xCtrLine-44 can handle is 800 W for 100 V line. Each output on the card can handle up to 200 W (100 V Line).
Impedance of the speaker lines can be measured for 1kHz in service mode as well as for 20kHz in normal mode.

Table 9. Technical data of ABT-xCtrLine-44

Model	ABT-xCtrLine-44
Power supply	Internal from the Control Unit backplane
Maximum current consumption	152 mA for 48 V
Type of connector	10 pin screw terminal type PHOENIX, 5.08 mm
Impedance measurement frequency	1 kHz to 48 kHz
Frequency of the signal for EOL modules	18 kHz to 24 kHz
Maximum measured current	2 A
Maximum measured voltage	200 V
Accuracy of measurement	Up to 5%
Operating temperature	-5°C to 40°C
Operating humidity	15% to 80%
Storage temperature	-20°C to 70°C (non-condensing)
Storage humidity	5% to 95% (non-condensing)
Dimensions	70 × 215 × 30 (mm)
Accessories	Screw terminals 10 pins, the distance between the partitions 5.08 mm

7.1.2.6 Loop monitor board LM8200 for short isolators

The LM8200 AB loop monitor is a device which is connected to the zone output circuitry of miniVES and midiVES systems. It is a solitary system which controls a loop speaker line network with IS8200 isolators. The PCB B board is able to power 66 isolators mounted on all 4 loops available on single LM8200 and controls the signal path in two ways: from left to right and vice versa.

The maximal output power per single loop board is 200 Watt. So LM8200 AB loop monitor is able to detect a loudspeaker configuration of 4 zones maximal 800 Watt RMS.

The IS8200 isolators are certified follow EN54-17:2005+AC2007. The system is built as shown on the next page.

miniVES system supports single LM 8200 with 4 loops

midiVES supports up to two LM 8200 – max 8 loops

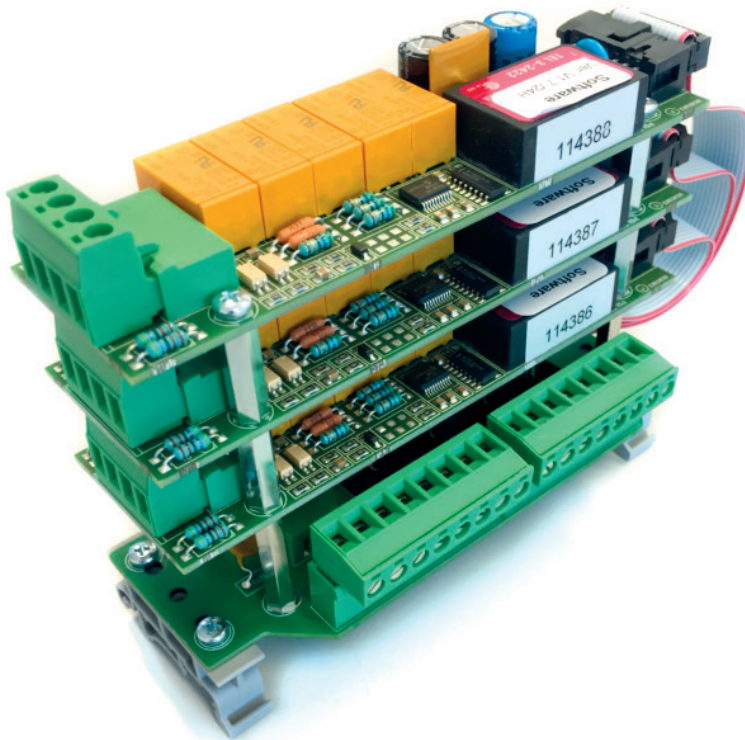

Drawing 29. LM8200 board

Power connection

The LM8200 module includes collective power for 4 loops. MAX 4×150 mA, 24 VDC

Picture below power input:

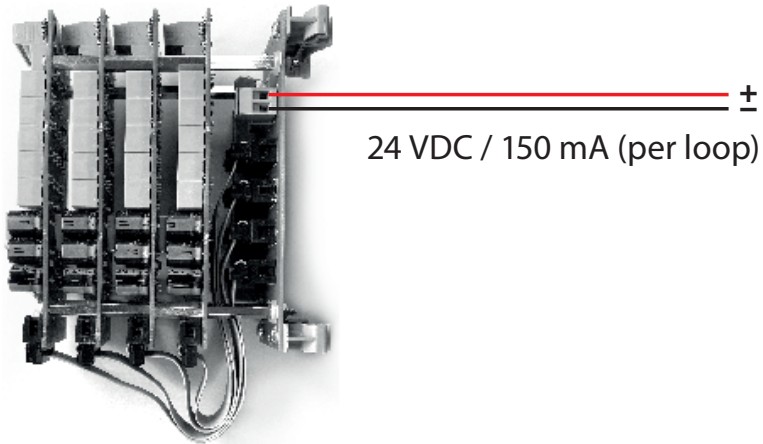

Drawing 30. LM8200 – board for 4 loops

To connect and power the LM8200 from miniVES or midiVES, use DDR-30L-24 converters and connect to 48 VDC (350 mA) output. It is a converter from 48 VDC to 24 VDC which is suitable for LM8200. Single DDR-30L-24 can power up to 2 LM8200 modules.



Drawing 31. DDR-30L-24 – converter 48 VDC to 24 VDC

Connection 100 V speaker line outputs to LM8200 board

The loudspeaker lines from the x-CtrLine-4/44 control cards should be connected as shown in the diagram below:

- » 1 – loop number 1 – top card
- » 4 – loop number 4 – bottom card

It is required to install in parallel TF-06-01 coils.

100V signal output connection to LM8200

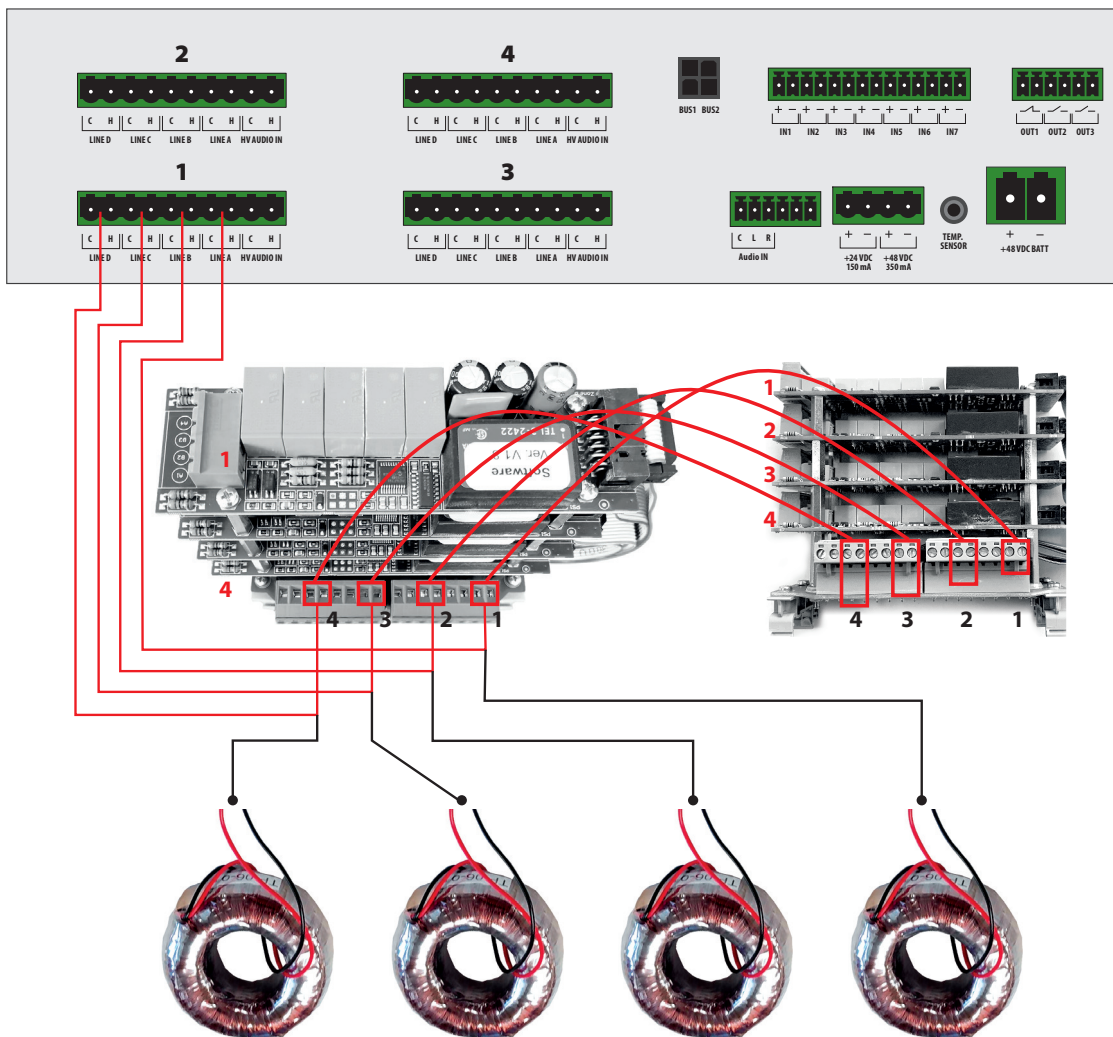

Drawing 32. Control card line outputs connection in parallel with TF06 chokes to LM8200 board

Connecting to each coil module ensures continuity of the DC 24 V circuit when switching the control card between the amplifiers and the internal generator.

Connecting 24VDC to LM8200

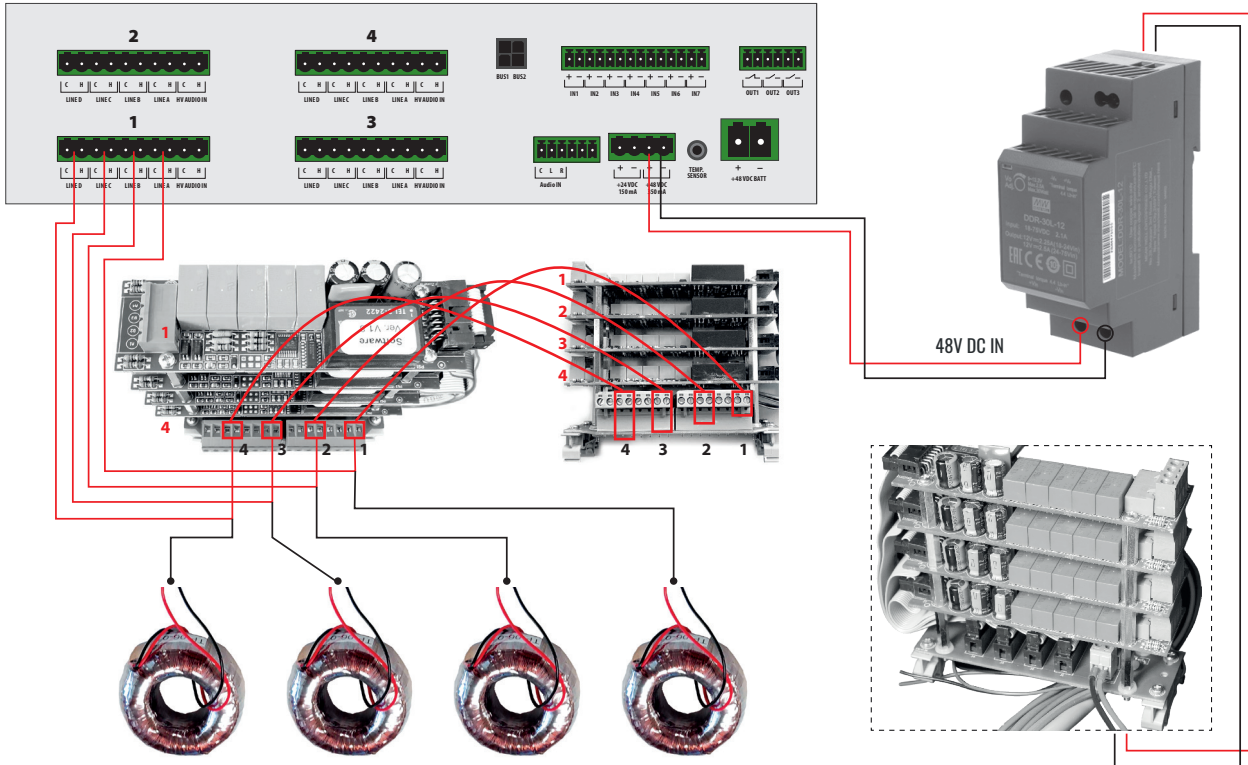

Drawing 33. Connecting 24VDC to LM8200

Connecting Fault Output to logical input available on mini and midIVES

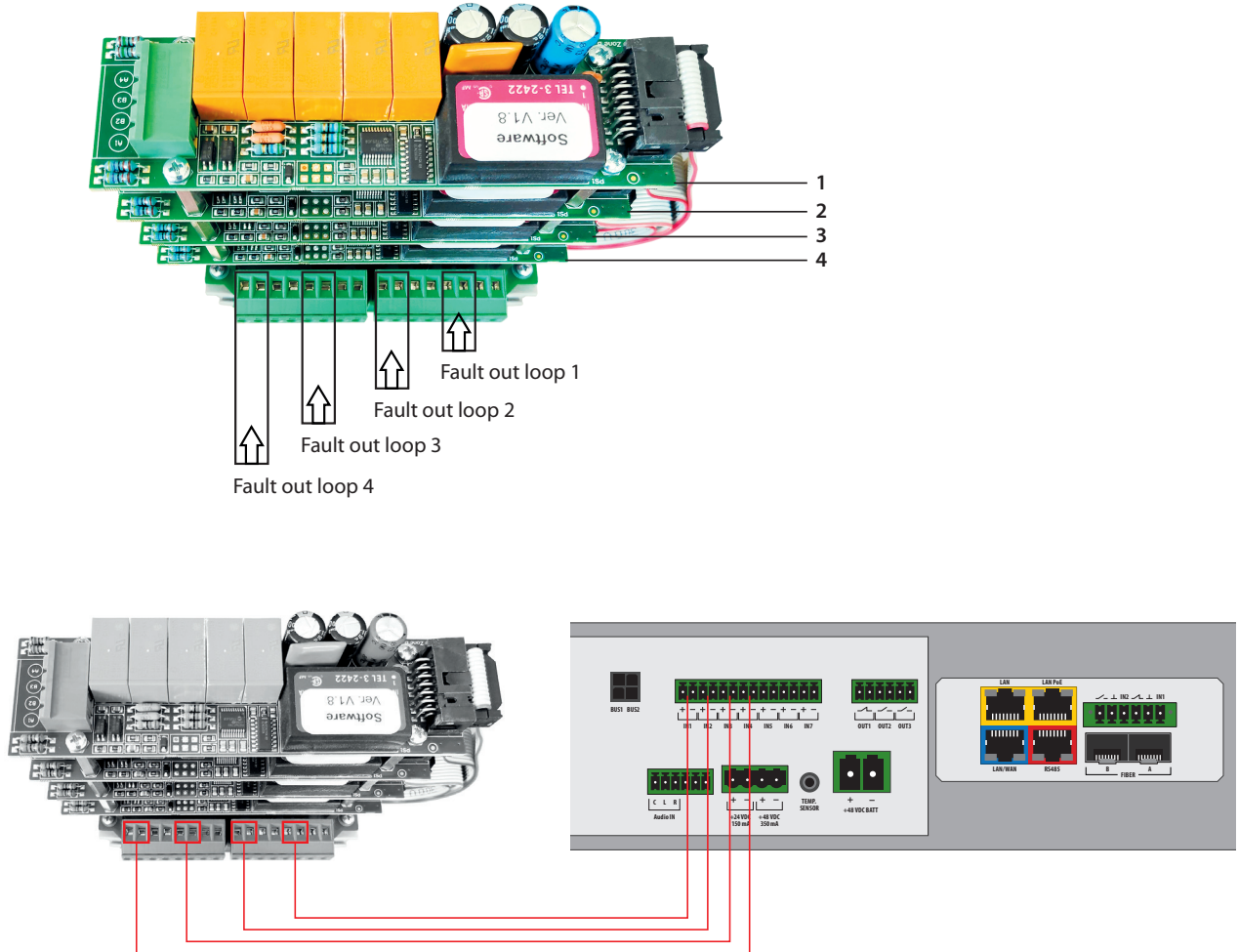

Drawing 34. Connecting Fault Output to logical input available on mini and midIVES

Each of the outputs in the correct operating state of the loop is NO (open), upon detecting a short circuit or an open circuit on the loop, the output goes into NC state.

When the entire system is powered up and the loop initializes (takes about 15 seconds), each output goes into the NC state. After 15 seconds, all outputs should be NO.

In the Selector software:

1. Give a name to the logic inputs – so that it is easy to identify which loop on which module is damaged. To do this, select the input card and change the name e.g. to Loop 1 etc.

Charger Inputs:				
	Name	Mode	Default	Events
1	Loop 1(#5)	Contact	NO	Events
2	Loop 2(#6)	Contact	NO	Events
3	Loop 3(#7)	Contact	NO	Events
4	Loop 4(#8)	Contact	NO	Events
5	Input 5	Contact	NO	Events
6	Input 6(#10)	Contact	NO	Events
7	Input 7(#11)	Contact	NO	Events

Communication Card Inputs:

2. Choose **Events** and assign the **External Fault CIN** function: Active - Start, Inactive – STOP

File View System Help

Event Configuration

Filter Functions: Off Filter Devices: Off

Input	Condition	Value	Function	Mode
24 DMS001.Key7(#7)	1 ^ v Active	N/A	External Fault CIN	Start
25 DMS001.Key8(#8)	2 ^ v Inactive	N/A	External Fault CIN	
26 DMS001.Key9(#9)				
27 DMS001.PTT(#10)				
28 DMSL001.PTT(#7)				
29 Alarm Mode(#1)				
30 Error(#2)				
31 Blocking(#3)				
32 Backup Power(#4)				
33 VirtualInput001(#255)				
34 VirtualInput002(#255)				
35 VirtualInput003(#255)				
36 CU001.Slot #9.Loop 1(#1)				

This way the system will display a fault named loop.

Connecting the outputs of the LM82000 module to insulators

- » PIN A1: is + outgoing to 1st isolator
- » PIN B2: is + return from the last isolator
- » PIN B3: is - return from the last isolator
- » PIN A4: is - outgoing to 1st isolator

Connection diagram with modules below:

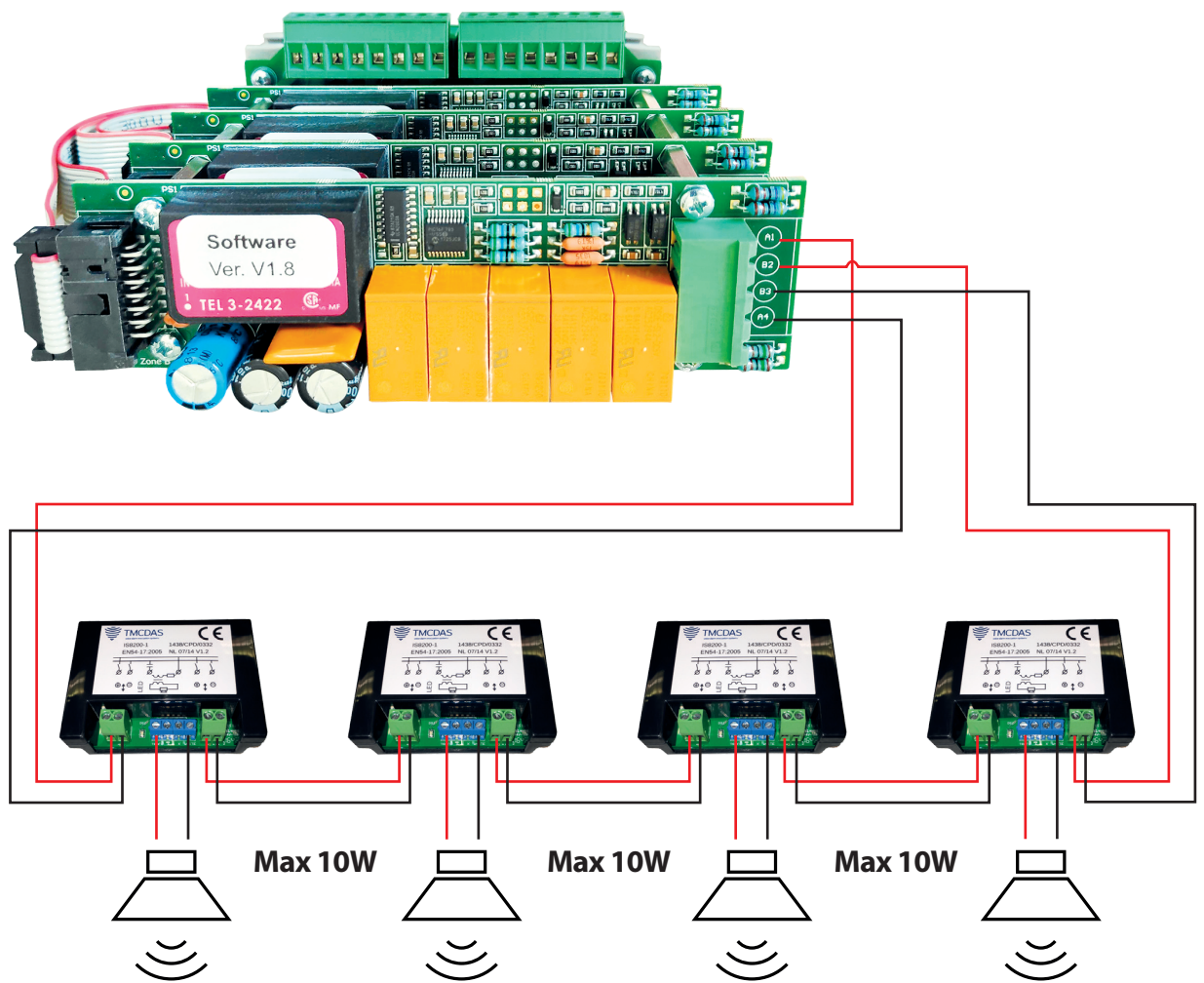

Drawing 35. Connection of isolators IS8200 to loop monitor board LM8200

Connecting the outputs of the LM82000 module to insulators

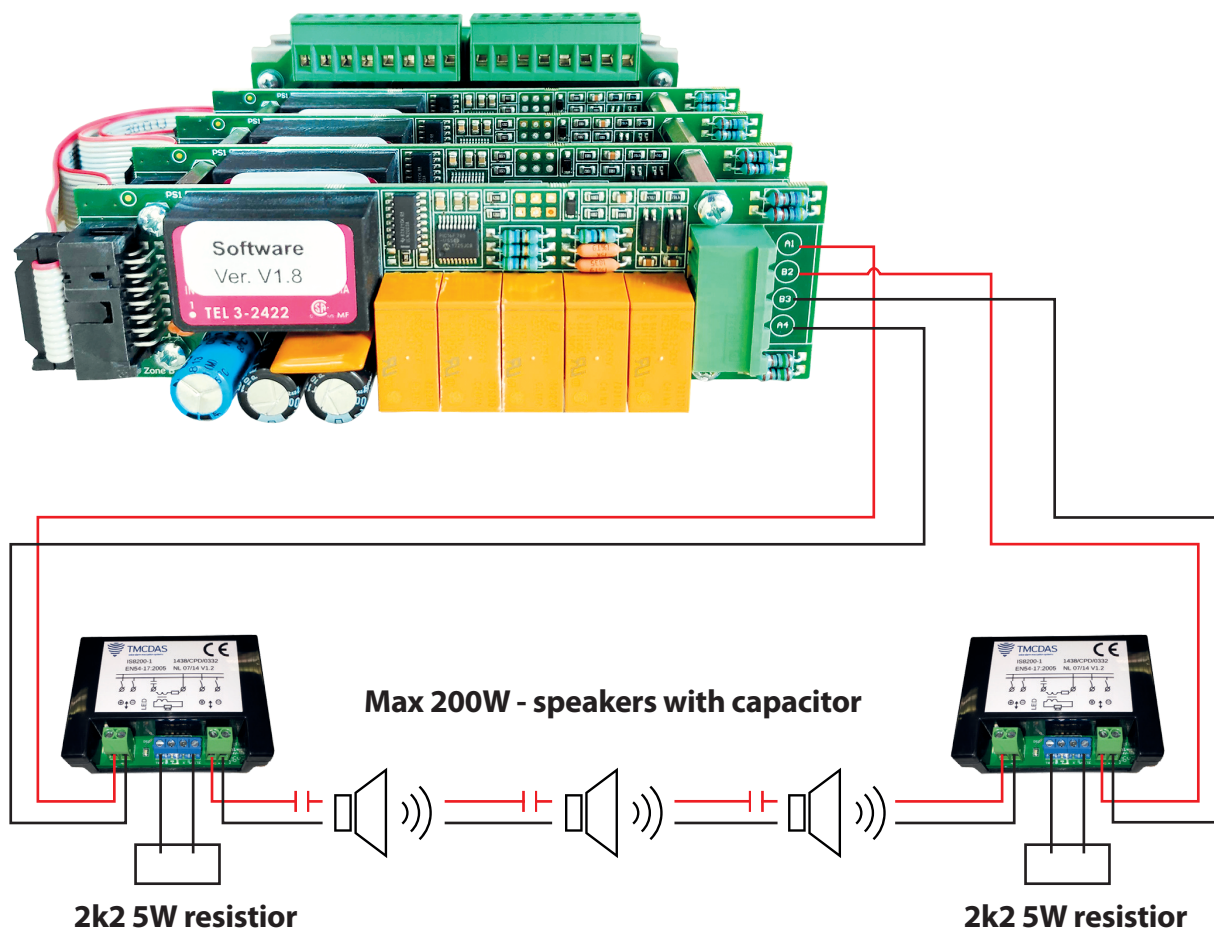

Drawing 36. Connection of isolators IS8200 to loop monitor board LM8200 - configuration speakers with capacitor between the isolators

Connecting short-circuit isolators

The isolator loop can be loaded with a maximum load of 200 W.

There can be a maximum of 66 IS8200-1 short-circuit isolators per loop.

Observe the polarity – reversing the polarity on the wiring disrupts the correct operation of the insulators.

Input to the isolator, e.g. from the LM8200 A1, A4 card to Input no.1, Output no.2 to the next insulator or return to the LM8200 B2, B3 card.

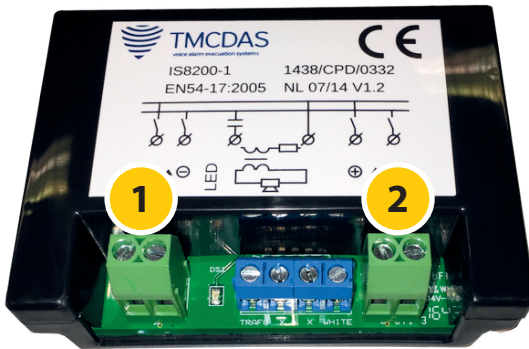

Connect the loudspeaker with a maximum of 10W to the TRAF0 and WHITE outputs as below - there is no need for a capacitor to eliminate the DC component at this output.

NOTE: In the absence of a loudspeaker, connect a 2k2 5W resistor to the TRAF0 and WHITE connectors – without closing the circuit with a resistor or a loudspeaker, the isolator does not work!



Another way to connect loudspeakers with insulators is not through a dedicated output (TRAF0 / WHITE) but between lines connecting the isolators. There is no 10W limitation here, but each loudspeaker must be connected through a DC blocking capacitor and the TRAF0 / WHITE circuit on each IS8200 short-circuit isolator with a 2k2 5W resistor should be closed.

Each short circuit isolator has a green LED to show the operating status:

1. System initialization blink × 4
2. Isolator in normal operation – single blink every 5 seconds
3. Loop open – no signalling on the LED (no need to insulate), the loop fault relay is activated
4. In case of a short circuit on one side of the isolator – the isolator disconnects the shorted side; LED blinks × 2 – short circuit on the left side; blinks × 3 – short circuit on the right side.

In the event of a short circuit in the installation – two insulators have blinking diodes: one insulator blinks the LED twice, while the insulator next to it blinks 3 times – the loop fault relay is activated.

7.1.3 Assembly and connection of ABT-LMK Master and ABT-LMK extension sets

ABT-LMK MASTER – loop mounting kit consists of:

- » 6x rubber pads
- » 4x 100V chokes
- » 2x plastic caps
- » 2x metal washers
- » 2x M6 square blots with nuts
- » 1x mounting rail with 2x M4 nuts
- » 1x 48VDC- 24VDC converter
- » 1x LM8200

1. **Screw the mounting rail with the supplied M4 nuts to the marked points. Mounting points are located on both sides of the housing.**

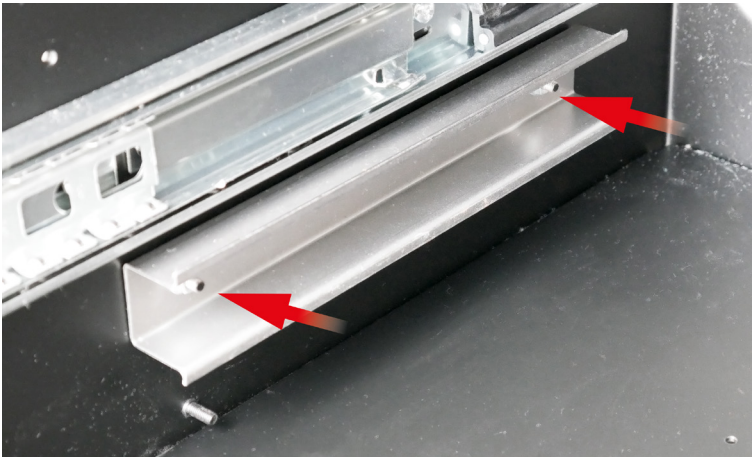

Drawing 37. Mounting rail assembly

2. **Put rubber pads in the designated places for the installation of 100V chokes.**

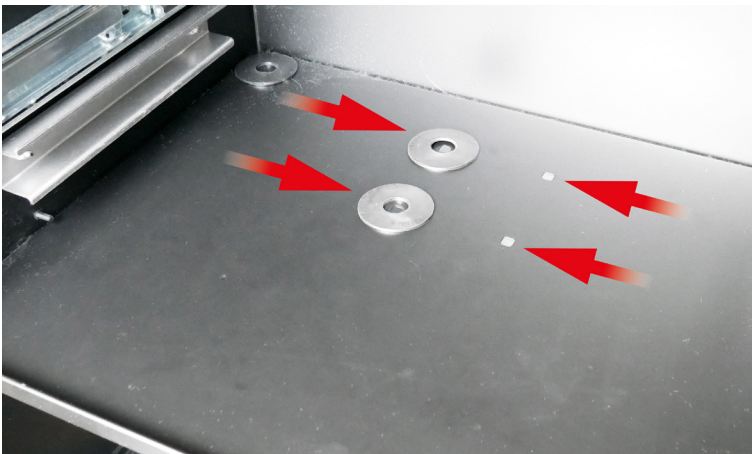

Drawing 38. Installation of rubber pads under 100V chokes

3. Place the 100V choke on the rubber pad and place another rubber pad on top.

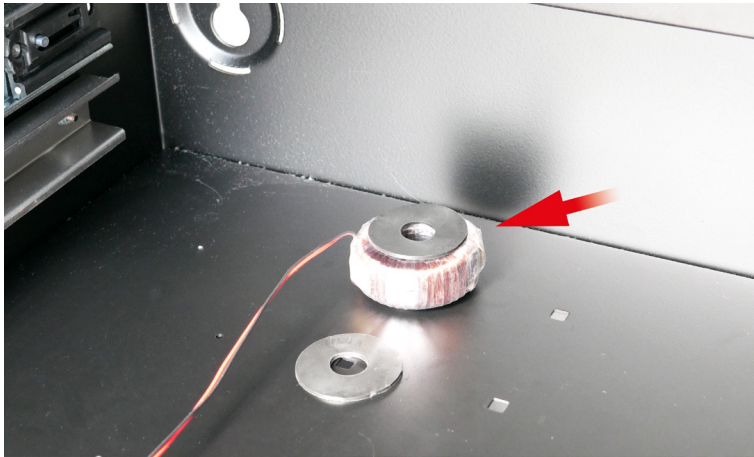

Drawing 39. Assembly of 100V chokes and rubber pads

4. Place the second 100V choke on the rubber pad.

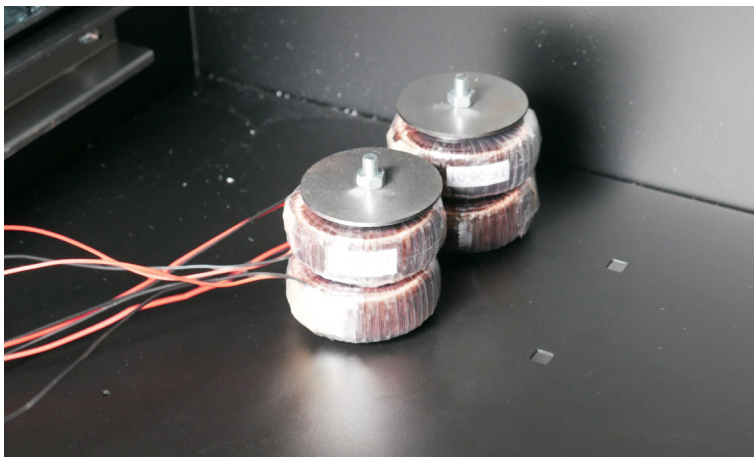

Drawing 40. Installation of second 100V choke on top of a rubber pad

5. Place the screw through the underside and hold it.

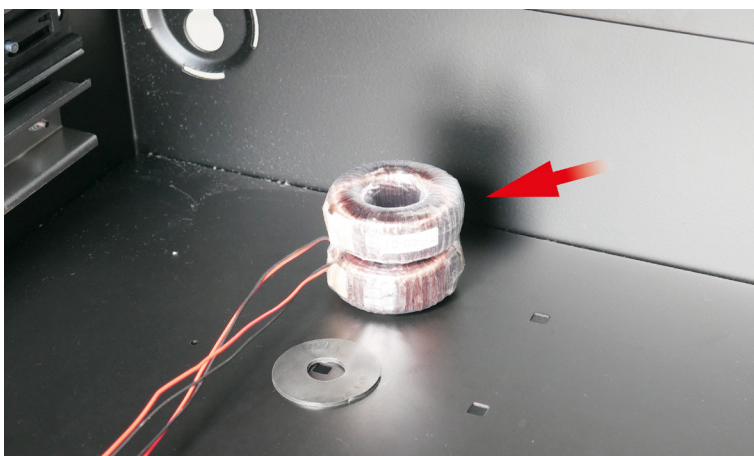

Drawing 41. Fixing 100V chokes with a screw

6. Put on a rubber pad, then a plastic cap and put a metal washer on top. Screw it on with the M6.

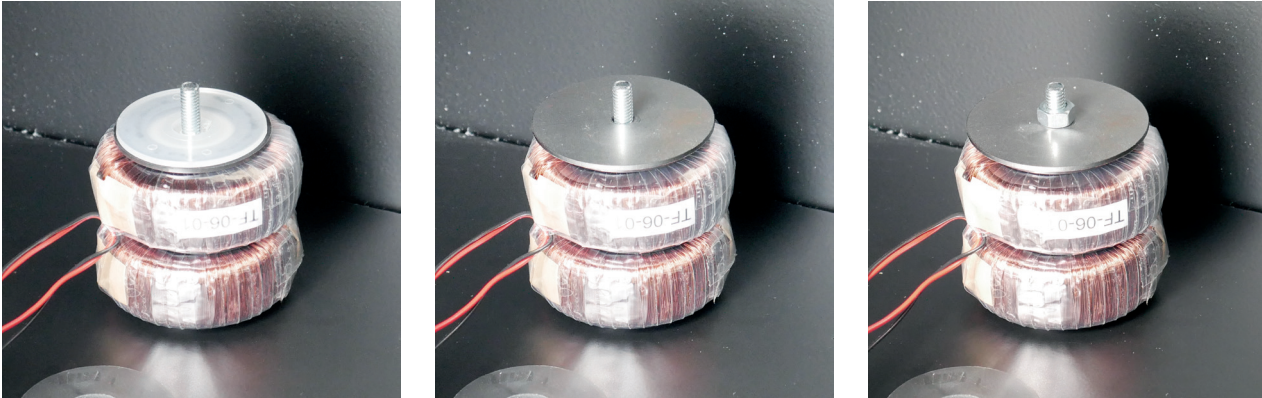

Drawing 42. Fixing 100V chokes with a M6 screw

7. Repeat steps 3 through 6 for the remaining 100V chokes.

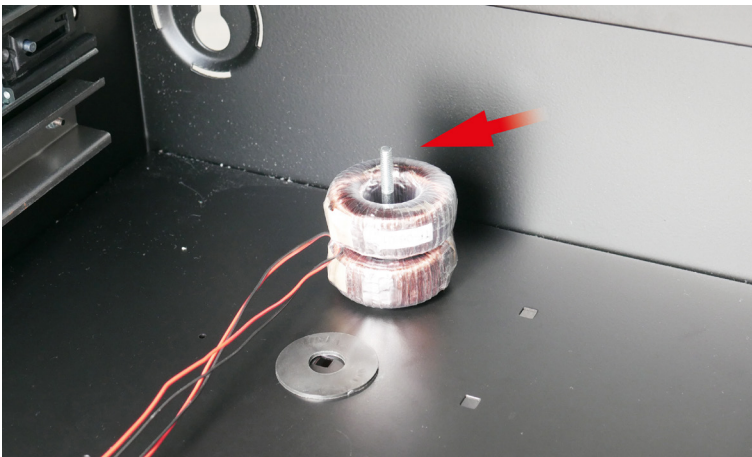

Drawing 43. Assembly of the remaining 100V chokes

8. Connect the 100V output from the control cards and connect the chokes to each input in parallel.

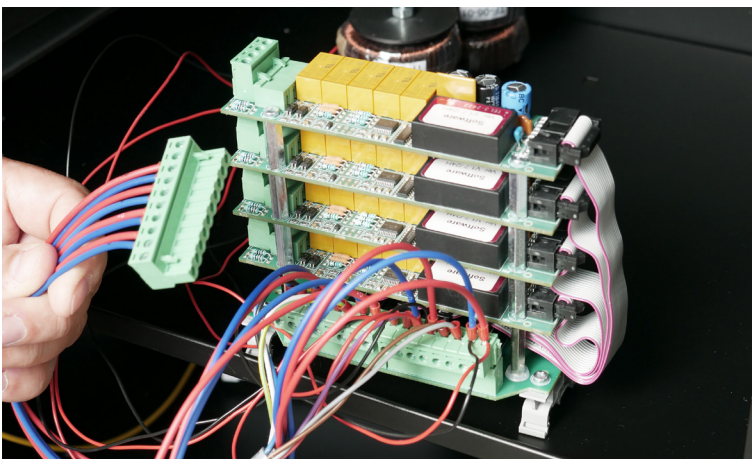

Drawing 44. Connecting each of the chokes to 100V output

NOTE: Please check Drawing 32. Control card line outputs connection in parallel with TF06 chokes .

9. Connect the 24V power supply to the LM8200.

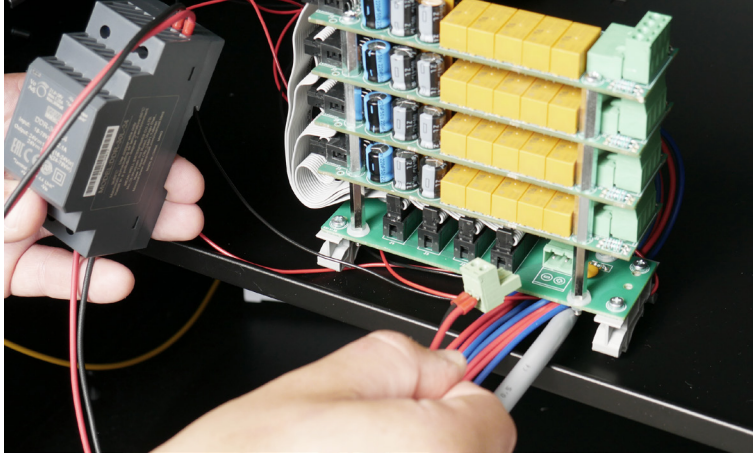

Drawing 45. Connecting 20V power supply to LM 8200

10. Mount the LM 8200 module and the DC-DC converter on the mounting rail. Place the outputs for connecting the loop with short circuit isolators towards the door.

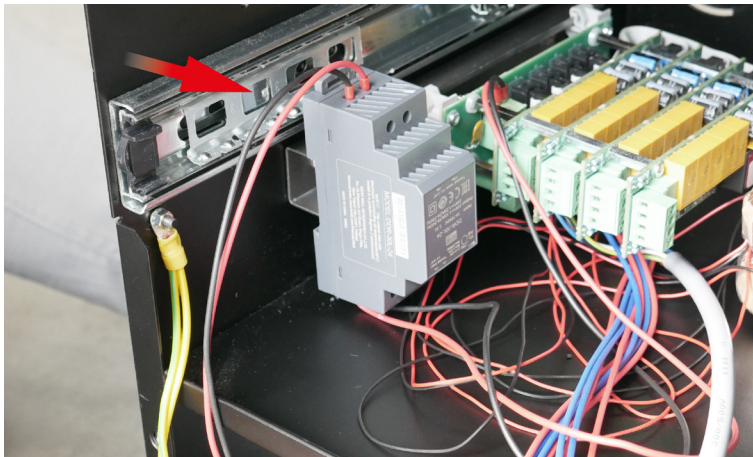

Drawing 46. Installation of LM 8200 module and DC-DC converter on mounting rails

ABT-LMK extension consists of :

- » 6x rubber pads
- » 4x 100V chokes
- » 2x plastic caps
- » 2x metal washers
- » 2x M6 square bolts with nuts
- » 1x mounting rail with 2x M4 nuts
- » 1x LM8200

ABT-LMK extension provides an extension for the next 4 loudspeaker loops. All elements can be mounted to dedicated holes for TF06 chokes and on the side of the housing to which provided DIN rail can be mounted. The 48VDC to 24VDC converter is included in the ABT-LMK MASTER set. The converter can supply up to two LM8200 modules simultaneously.

7.1.4 Built in amplifier modules

The miniVES and midiVES systems are equipped with built in amplifier modules. This enables standalone operation as a complete VAS system.

Built in amplifier module options:

1. **miniVES 2001 series** units use two 160 W RMS amplifier modules and a single switchable transformer. This enables one of the amplifiers to work as the main unit, with total audio load 320W, while the second one provides redundancy
2. **miniVES 4001 series** units use two 320 W RMS amplifier modules with two transformers. This enables one of the amplifiers to work as the main unit while the second one provides redundancy. Total audio load is 640W.
3. **miniVES 4002 series** units use two 320 W RMS amplifier modules with two transformers. This enables both of the amplifiers to work either simultaneously with the total output limited to 640 W or with one used as main and the other one as backup.
4. **midIVES 8003 series** units uses three 500 W RMS Class D transformerless amplifiers. Systems can use all three amps at the same time extending the total available power up to 1500W.

Ensure that the volume level of audio sources is set to minimum and the loudspeakers and all equipment are connected properly before turning the amplifier on.

CAUTION: The system is activated about 10 seconds after turning the device on. This is the regular operation of the amplifier that results from work of embedded automatic protection of circuits, loudspeakers and other connected components.

7.1.4.1 Technical details

Table 10. Technical specifications of amplifier modules

Model	160 W miniVES 2001	320 W miniVES 4001/4002	500 W midIVES 8003
Specifications			
Type	Class D	Class D	Class D- -transformerless direct output
Audio channels	1	2	3
Output voltage	50 V, 100 V	50 V, 100 V	105 V
Power supply	DC	DC	DC / AC
Power supply voltage	48 V (42-57 VDC)	48 V (42-57 VDC)	85 – 265 VAC 36 – 60 VDC
Rated load	62,5 Ω + 200 nF	31,25 Ω + 200 nF	20 Ω
Pass band (-3 dB)	75 Hz – 20 kHz	75 Hz – 20 kHz	3 Hz – 35 kHz
Channel separation	> 70 dB	> 70 dB	> 70 dB
Signal to noise ratio SNR	> 80 dB (curve A)	> 80 dB (curve A)	> 95 dB (curve A)
Total harmonic distortion THD (rated load / 1 kHz)	0,1%	0,1%	0,04%

7.1.5 miniVES Charger

The Charger module is responsible for distribution of uninterrupted power supply for all internal units and auxiliary outputs. It supplies the devices with guaranteed 42...57,6 VDC and 24 VDC.

As a main source of power it uses a switching power supply Unit; as a source of back-up power supply, it uses the VRLA battery bank consisting of four 12 V batteries with the capacity of up to 60 Ah.

Charger module monitors fuses and output parameters of each circuit, it maintains the battery in charged condition, ensures temperature compensation of charging parameters and monitors series resistance of the battery and its wiring in compliance with Exhibit No. A2 of the EN 54-4 Standard.

Charger module ensures uninterruptible switching to back-up battery power in case of main power decay or failure of the Power Supply Unit.

Additionaly Charger module supports:

- » 7 logic inputs and 3 relay outputs,
- » auxiliary "BUS CTRL" port for connecting the wiring loom for two line control cards (only in the miniVES 4002x series devices)
- » replaceable battery for the internal system clock
- » audio line in, unbalanced, with stereo to mono conversion (1 ch)
- » audio line out, unbalanced (1ch for L+R out)

In order to connect the batteries to the charger use the battery cable supplied with the device. Be sure of proper connection (polarity) between batteries and terminals. Lastly connect the thermistor temperature sensor to the "TEMP SENSOR" jack and place it near installed batteries. Only unused and type compliant batteries (same manufacturer, equivalent capacity and voltage, same manufacturing date) may be connected.

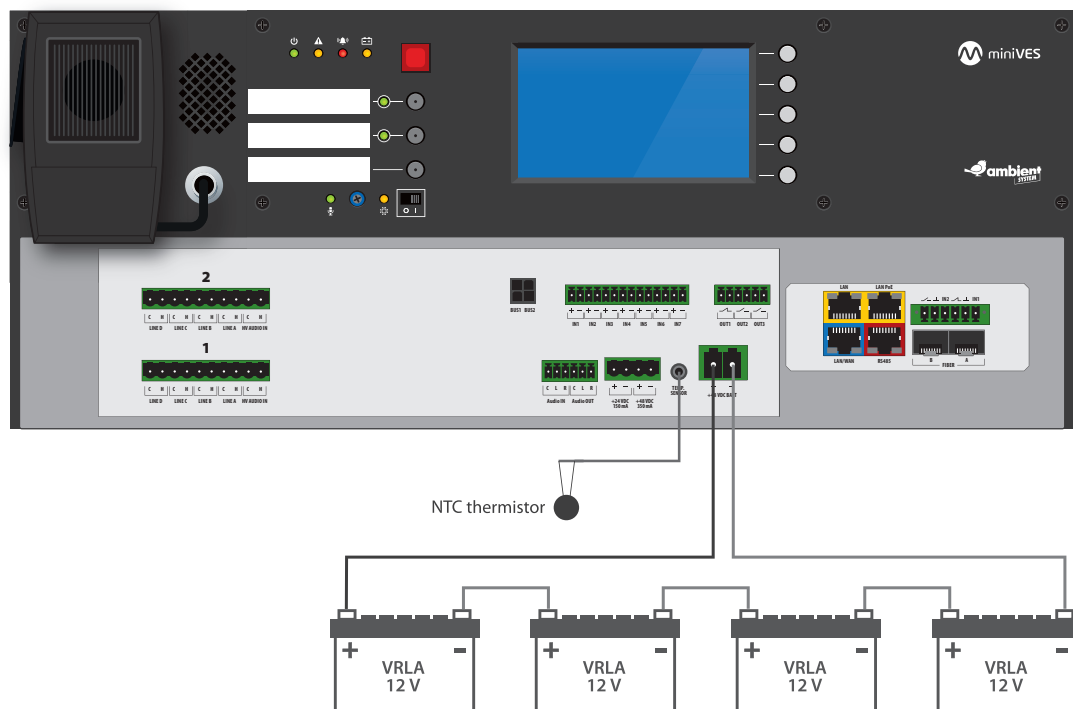

Drawing 47. Connection between VRLA batteries, temp. sensor and miniVES Charger module

Connecting miniVES 8003LNR with 8003R:

For connecting miniVES 8003LNR with 8003R we can use a single set of 4x12V (VRLA) batteries which is shared between 8003LNR and 8003R.

Please remember to set the capacity of the batteries on unit 8003LNR only and select no batteries option in 8003R when using the same batteries. Below are schematic how to connect batteries to the miniVES 8003LNR and 8003R using dedicated panel:

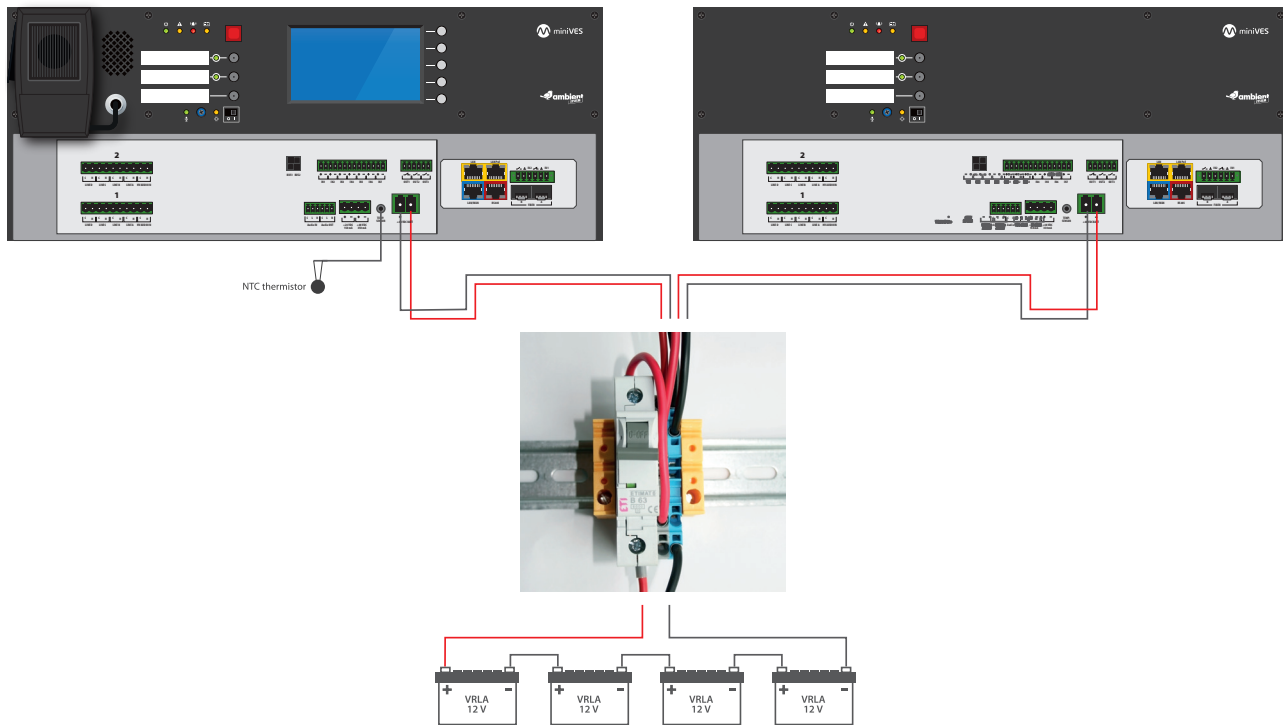

Drawing 48. Connecting miniVES 8003LNR with 8003R with a set of 4x12V batteries

Table 11. Technical specification of the miniVES Charger card

Model	miniVES Charger
Electrical	
DC main power supply	54 VDC from Power Supply Unit
DC input	Edge connector to backplane
DC input protection	15 A 63 VDC SMD slow-blow fuse (non replaceable)
DC outputs	Internal (edge connector):
	<ul style="list-style-type: none"> > 2 × 48 V for power amplifiers, each output max. 10 A 42...57 VDC > 48 V for PoE, max. 1 A > 5 V max. 3 A > 12 V max 1,7 A > -12 V max 0,3 A
	Ext (Phoenix-type connector, 3.5 mm raster):
	<ul style="list-style-type: none"> > 1 × 24 V max. 0,15 A > 1 × 48 V max. 0,35 A

DC output protection	Int: › Amplifiers supply: replaceable fuses 58 VDC Low Profile Mini 891 series blade fuse › 5 A for 2xxx series, 10 A for 4xxx series Ext: › 48 V output: 0,5 A non replaceable PTC fuse › 24 V output: 0,2 A non replaceable PTC fuse
Summary maximum all DC output loads	Total output DC load shouldn't exceed 500 W
Backup Power Supply	
Battery (type)	4 pcs., VRLA 12 V 15-65 Ah
Charging method	constant voltage or multi-stage
Charging current	2,3 A max.
Charging voltage	54,6 V ± 0,6 V (at 25°C)
Temperature correction coefficient	-80 mV/ °C
Battery connection	Dedicated wiring Phoenix Contact 1720466 with AWG8 connection cord 4 × 12 V
Battery circuit protection	Fuses 58 VDC Low Profile Mini 891 series blade fuse Positive cord: 7,5 A for 2xxx series, 15 A for 4xxx series Negative cord: 20 A
Maximum total serial resistance of wiring, fuses and batteries	60 - 160 mΩ (adjustable in configuration SW)
Temperature	
Temperature sensor	Dedicated temperature sensor
Operating temperature	-5°C to +40°C

7.2 External devices

7.2.1 ABT-DFMS fireman microphone

The fireman microphone is intended to do the following:

- » transmit voice messages or system warning and evacuation messages to selected zones during fire-fighting,
- » activate emergency messages,
- » call general-purpose messages,
- » select particular zones,
- » send voice messages "live".

The microphone power is supplied locally by a certified fire cord (48 V) or remotely by PoE.

The device has programmable function buttons which can be assigned given functions. It is also possible to connect up to 5 ABT-EKB-20M extensions with an additional 20 function buttons each. Up to 253 fireman microphones can operate in a single system. The microphone communicates with control units either through an ethernet network or via an optical fiber connection (1000BASE-X).

Another system function is the "CPU OFF" function. The entire system enters a state allowing transmission of voice messages from the unit on which this function is activated to all alarm zones without the use of the control unit. This enables the system to transmit to all zones even during central processor failure.

The microphone automatically detects and indicates failures such as function button damage and audio signal track damage.

It is possible to connect keyboard extension by a dedicated 10 pin female connector on the right side wall. The microphone is equipped with 2 slots for SFP modules, 2 LAN 10/100/1000 ports, 1 LAN 10/100 port, 1 RS485 port.

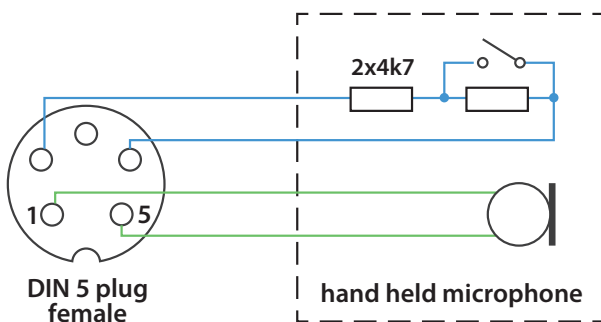

Drawing 49. Microphone pins diagram

Main features:

- » Built-in 2 contact inputs and 2 relay outputs
- » Powered using PoE or external PSU
- » Black-box function – recording all announcements played back during an alarm
- » Built-in SFP modules and CAT5e for flexibility in topology choice (either loop or star)
- » RS 485 for communication with external systems
- » Intercom function between all fireman and zone microphones

Main system functions:

- » Reporting equipment errors detected on cards
- » Reporting incorrect input voltage level (short-circuit/open-circuit)
- » Defining short-circuit/open-circuit/high/low level statuses for every output
- » Controlling any logic output via any system module which supports scripts
- » Using values/status of any output via any system module which supports scripts
- » Calling scenarios, actions by any input status
- » Assigning any output to any system event
- » Defining NC/NO inputs

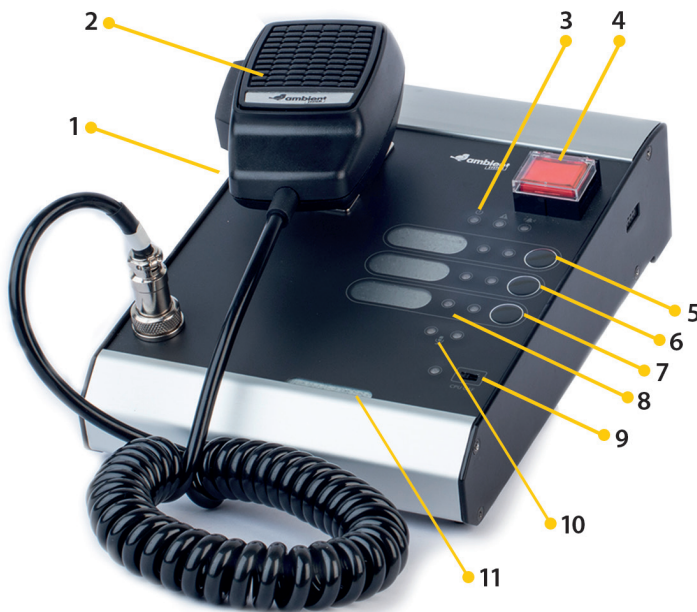

Drawing 50. ABT-DFMS fireman microphone

1. **Built-in loudspeaker**
2. **Microphone with "Push to talk" button**
3. **LED indicators** for: Power [green], Failure [yellow], Evacuation [red] (EVAC)
4. **"Activate Evacuation" button**
5. **Functional button** – can be programmed in any way, most frequently as "Evacuation"
6. **Functional button** – can be programmed in any way, most frequently as "Warning"
7. **Functional button** – can be programmed in any way, most frequently as "Cancel alarm"
8. **LED indicators for functional buttons**
9. **CPU OFF switch** – green LED indicates the CPU-OFF active mode
10. **Broadcasting readiness indicator** – flashing green LED after pressing the PTT signals readiness to broadcast a message.
11. Button description card slot

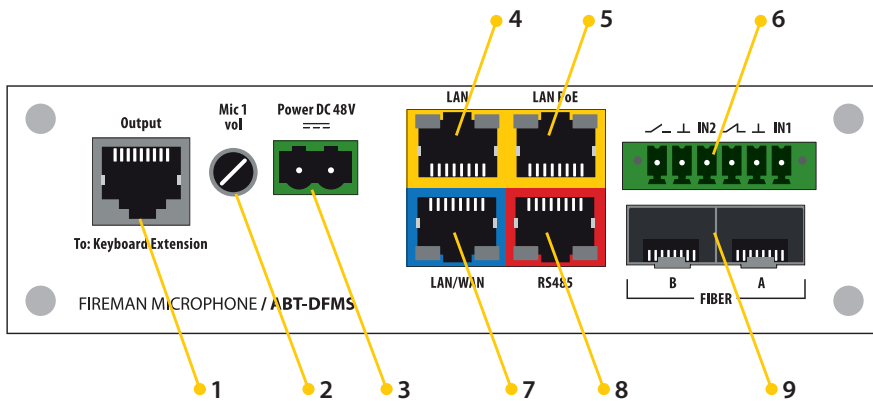

Drawing 51. Upper panel of fireman microphone

1. **RJ45 socket** to connect microphone extension ABT-EKB-20M
2. **Microphone gain level adjustment** from -6 dB to +6 dB
3. **2-pin socket to connect power supply** in accordance with EN54-4
4. **RJ45 socket to support LAN connections**
5. **RJ45 socket to support LAN with PoE connections** – it is possible to power the microphone directly from the Control Unit via one CAT5 cable (data + voltage)
6. **Phoenix-type connector, two logic inputs or two relay outputs** (every channel is configured on a case-by-case basis, and by default, both are set as parametric inputs)
7. **RJ45 socket to support LAN/WAN connections**
8. **RJ45 socket** in accordance with RS485 transmission standard
9. **Two SFC module slots**

ABT-DFMS fireman microphone consists of the ABT-xNET-1Gb/WAN/RS communication card coupled with the fireman microphone keyboard module, extension support module and power supply module.

Table 12. Technical data of ABT-DFMS fireman microphone

Model	ABT-DFMS
Power source	via LAN PoE or local power supply compliant with EN 54-4
Input voltage	48 V connector 2 pin screw 5.08 mm
Power consumption	max 266 mA for 48 V DC / 5 keyboard extensions
Protection rating	30
Transmission medium	fiber, UTP Cat. 5e
Number of logic inputs	2
Number of relay outputs	2
Connector type for logic input/output	screw 3.5 mm, 6 pin
Type of fiber optic	modules type SFP / connector SC / LC / multimode or single-mode / E 30 or E 90, OM lub OM2

Listening speaker	
Output	0,5 W
SPL	78 dBA (@1 m, 1 W)
Frequency response (3 dB)	450 Hz ... 8 kHz
Audio input	
Frequency response	400 Hz – 6 kHz (@3dB)
Impedance	500 Ω
Signal	-40 to 30 dBu
Sensitivity	-66 dB
Cable type, length	spiral – 1,5 m
Microphone connector	5 pin DIN
Keyboard and controls	
Number of buttons	3
Number of control panel buttons	2 LED / button
Dimensions of the buttons description	15 × 25 mm
Three normative LED controls	color LEDs: power – green / failure – yellow / alarm – red
Logic Input / Output	
Number of I / O logic	2 independent channels; galvanically isolated; each channel has 1 fully programmable input and output (NO / NC)
Switching current (Max.)	1 A peak*
Switching voltage (Max.)	50 V AC / DC peak*
Switching power (Max.)	30 W*
Parametric input source for monitor mode	passive; standard resistors 10 k 10 kΩ or 4,7 kΩ - - 4,7 kΩ detection thresholds 0/1 / open / set in the application configuration
Type of socket I / O logic	6-pin screw terminal type PHOENIX, 3.5 mm
CPU-OFF switch	slide switch, two position, signaling LED color: yellow
Other parameters	
Operating temperature	-5°C to 40°C
Operating humidity	15% to 80%
Storage temperature	-20°C to 70°C
Storage humidity	5% to 95%
Dimensions	150 (W) × 55 (H) × 210 (D) mm
Accessories	connector with screw terminals 6 pins, the distance between the partitions 5.08 mm

*** IMPORTANT!**

Any DC combination of V & A not to exceed switching power max value.

Not allowed capacitive nor inductive load, because of large inrush current / voltage spike, that can significantly exceed the maximum allowed switching current or voltage.

7.2.2 ABT-DMS zone microphone

Zone microphone is used to:

- » call general-purpose messages,
- » select particular zones,
- » send voice messages “live”.

This zone microphone is used to activate general public announcements, to choose individual zones and to broadcast live voice messages. It can be connected directly to a selected Control Unit or via an additional Ethernet switch. A zone microphone can be powered locally (48 V) or from a Control Unit via POE.

It is equipped with programmable function keys which can be used to assign functions as required. All operational parameters can be programmed e.g. assignment of zones to various keys, naming of zones and zone groups, determining priorities, setting up access rights to announcements, volume controls, ‘push to talk’ key, music on/off and music routing. Furthermore, LEDs on the ABT-DMS provide information about existing fault on the system, any faults in a specific speaker zone, evacuation mode on and type of announcement in the zone (BGM, PA, EVAC, Warning, fireman microphone).

Up to 5 ABT-EKB-20M keyboard extensions with additional function keys can be attached to a zone microphone.

Similarly to a fireman microphone, it is also equipped with an intercom function and is able to communicate with other microphones in the system.

Main features:

- » Monitored connection of the unit to the system
- » 9 fully-programmable keys with a possibility of connecting up to five 20-key extensions
- » 4 non-symmetrical audio inputs, (1/8”) stereo jack connector
- » Built-in speaker
- » Stereo jack sockets for a headset use
- » Implemented intercom function
- » Power supply via POE

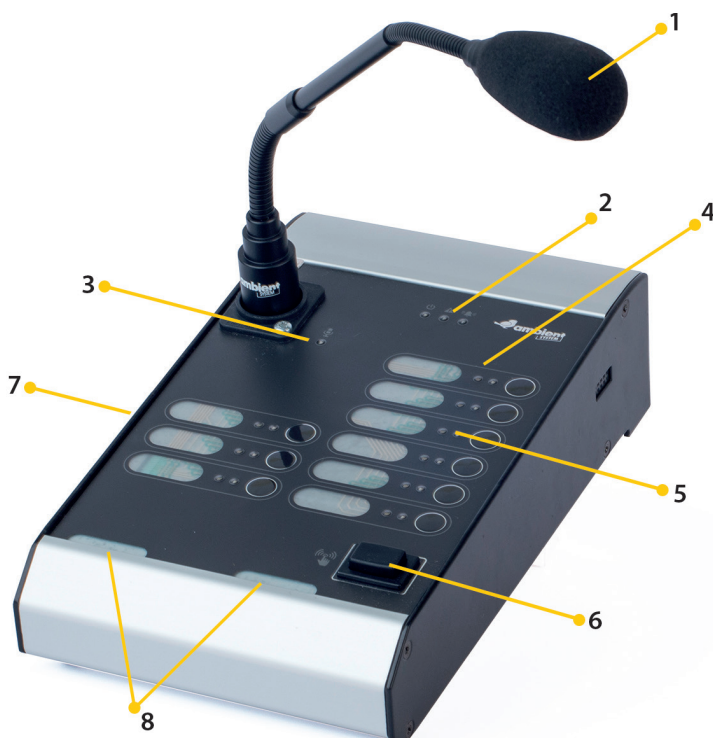

Drawing 52. ABT-DMS zone microphone

1. **Microphone**
2. **LED indicators** for: Power [green] (Power), Failure [yellow] (Fault), Evacuation [red] (EVAC)
3. **Active microphone LED** – the LED signals that the device is ready to transmit a voice message, if a gong is programmed, the microphone activates shortly after the sound is emitted
4. **Functional buttons** – freely programmable
5. **LED indicators for functional buttons**
6. **“Push to talk” button** – the button is programmed in order to activate microphone
7. **Built-in loudspeaker**
8. Buton description card slot

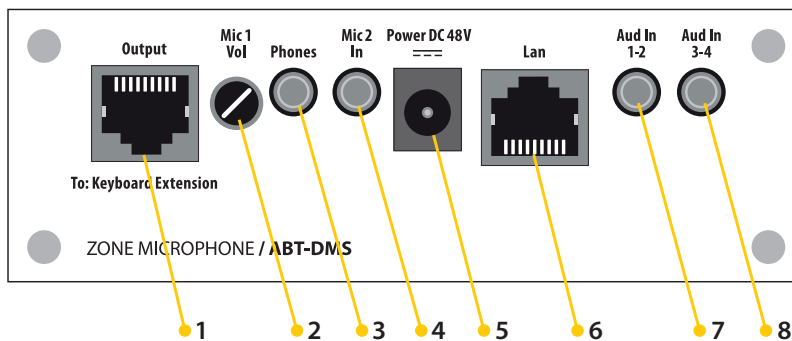

Drawing 53. ABT-DMS zone microphone connectors diagram

1. **RJ45 socket to connect microphone extension ABT-EKB-20M**
2. **Digital potentiometer**
3. **Headset 1/8" jack socket**
4. **Headset mic 1/8" jack socket**
5. **Power point 48 V**
6. **Communication port** providing connection with the control unit with the possibility to receive PoE when connected to the ABT-xNET_mini series cards
7. **2 Audio inputs**
8. **2 Audio inputs**

Table 13. Technical data of ABT-DMS zone microphone

Model	ABT-DMS
Power supply	via PoE (RJ45) or by additional 48 V power supply / 15 W DC connector 5,5 / 2,1 mm
Protection rating	IP 30
LCD	N/A
Number of outputs	2 channel audio (monitor speaker, headset)
Number of inputs	4 channels (single-ended input bgm)
Listening speaker	
Output	0,5 W
SPL	78 dBA (@1m, 1 W)
Frequency response (3dB)	450 Hz ... 8 kHz
Output for headphones (headset)	mini-jack 3,5 mm
Audio Inputs	
Input type	single-ended, 4 × bgm
Frequency response	50 Hz ... 18 kHz (@3dB)
ADC resolution	32 bit
Sampling frequency	48 kHz
Connector	2 × mini-jack 3,5 mm
Microphone input	
Input, connector type	balanced inputs, XLR
Condenser microphone, gooseneck	
Frequency response	100 Hz ... 10 kHz
Sensitivity	-45dB
Keyboard and controls	
Number of keys	9 + PTT
Additional three normative controls	power – green / failure – yellow / activity – green
LED colors	RGB (red, green, yellow, blue)
Other parameters	
Operating temperature	-5°C to 40°C
Operating humidity	15% to 80%
Storage temperature	-20°C to 70°C
Storage humidity	5% to 95%
Dimensions	120 (W) × 55 (H) × 210 (D) mm
Weight	1,4 kg

7.2.3 ABT-DMS-LCD – zone microphone with LCD

For intuitive and easier operation, ABT-DMS-LCD has been equipped with a touch-screen display. Navigation in the menu and change of settings is possible by means of both control buttons located next to LCD display, and touch-screen display. ABT-DMS-LCD can only be used for purposes not related to evacuation/ alarm.

Zone microphone is equipped with intercom function which provides two-way communication between the zone microphones. ABT-DMS-LCD has 4 local audio inputs on board and 1 audio output which allows for further system extension. Communication with control units takes place via Ethernet 10/100BASE -TX, 1 LAN port.

Main features:

- » 4,5" LCD touch screen for fast and clear matricing and system management
- » Four non-symmetrical audio inputs, (1/8") stereo jack connector
- » Built-in speaker
- » Stereo jack sockets for Headset / Audio out
- » Implemented intercom function
- » Extension up to five 20-button modules
- » Power supply via POE or locally 48 VDC

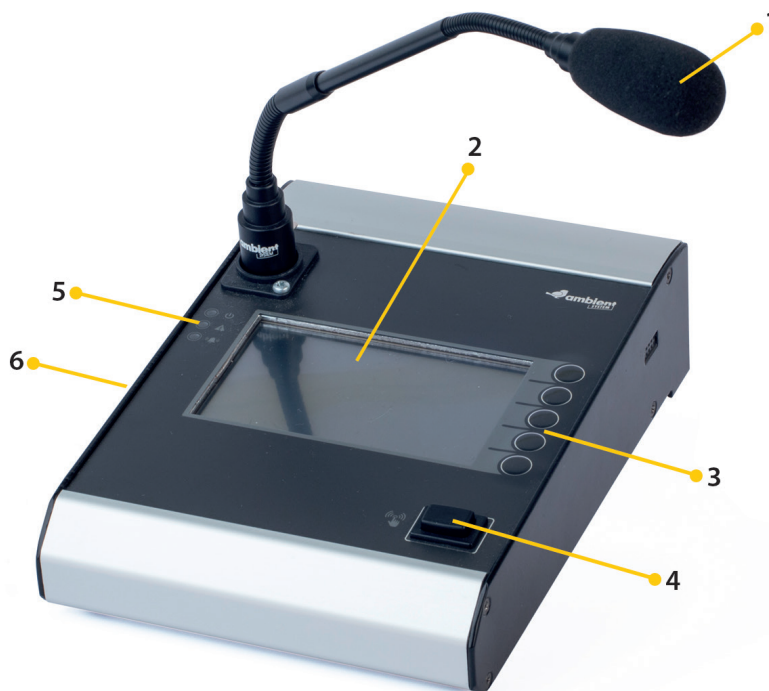

Drawing 54. Zone microphone with ABT-DMS-LCD display

1. **Microphone**
2. **Display**
3. **Functional buttons** – by default they support auxiliary functions when navigating in the menu:
 - a. HOME – press to return to first menu page
 - b. ENTER – ENTRANCE button– press to select in the microphone menu
 - c. ↑ – up-arrow button – press to navigate in the microphone menu
 - d. ↓ – down-arrow button – press to navigate in the microphone menu
 - e. BACK – BACK button – press to return to previous microphone menu item
4. **“Push to Talk” button** – program this button to activate microphone
5. **LED indicators** for power [green], failure [yellow], evacuation [red] (EVAC)
6. **Built-in speaker**

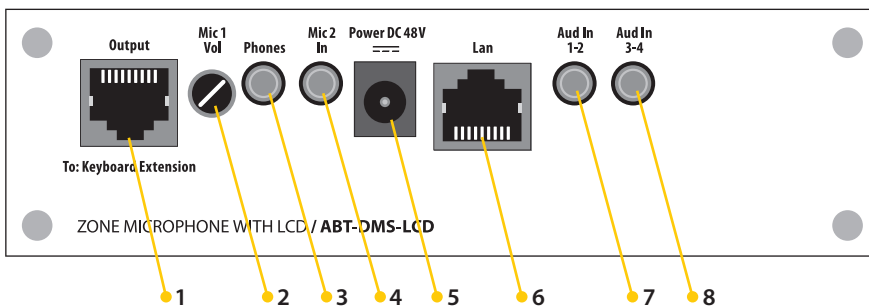

Drawing 55. ABT-DMS-LCD zone microphone connectors diagram

1. **RJ45 socket to connect microphone extension ABT-EKB-20M**
2. **Digital potentiometer**
3. **Headset 1/8" jack socket**
4. **Headset mic 1/8" jack socket**
5. **Power point 48 V**
6. **Communication port** with control unit and possibility of supplying microphone via LAN PoE port (works only when ABT-xNET-1Gb/WAN/RS communication card has been supplied with PoE support)
7. **2 Audio inputs**
8. **2 Audio IN inputs**

Table 14. Technical data of ABT-DMS-LCD zone microphone

Model	ABT-DMS-LCD
Power supply	via PoE (RJ45) or by additional 48 V power supply / 15 W DC connector 5,5 / 2,1 mm
Protection rating	IP 30
LCD	LCD, 272x480 resolution, 4.3 "resistive touchscreen
Number of outputs	2 channel audio (monitor speaker, headset)
Number of inputs	4 channels (single-ended input bgm)
Listening speaker	
Output	0,5 W
SPL	78 dBA (@1m, 1 W)
Frequency response (3dB)	450 Hz ... 8 kHz
Diameter	50 mm
Output for headphones	mini-jack 3,5 mm
Audio Inputs	
Input type	single-ended, 4× bgm
Frequency response	50 Hz ... 18 kHz (@3dB)
ADC resolution	32 bit
Sampling frequency	48 kHz
Connector	2× mini-jack 3,5 mm
Microphone input	
Input, connector type	balanced inputs, XLR
Condenser microphone, gooseneck	
Frequency response	100 Hz ... 10 kHz
Sensitivity	-45 dB
Keyboard and controls	
Number of keys	5 + PushToTalk
Additional three normative controls	power – green / failure – yellow / activity – green
Other parameters	
Operating temperature	-5°C to 40°C
Operating humidity	15% to 80%
Storage temperature	-20°C to 70°C
Storage humidity	5% to 95%
Dimensions	150 (W) × 55 (H) × 210 (D) mm
Weight	1,4 kg

7.2.4 ABT-EKB-20M – microphone keyboard extension

Every extension added to fireman microphone or zone microphone provides additional 20 functional buttons. The extension has two I2S interfaces to connect another extension. In accordance with EN54-16, one of the buttons should be assigned to a visual and sound signal test of the microphone unit.

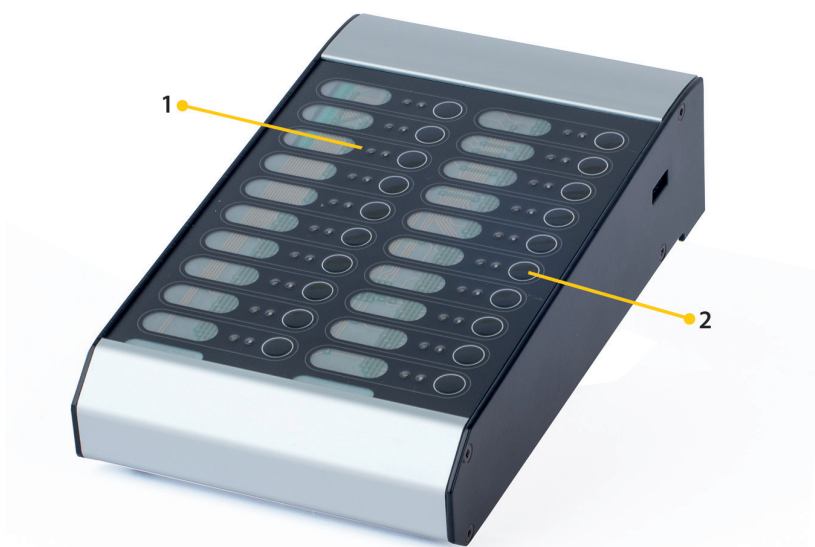

Drawing 56. ABT-EKB-20M microphone extension

1. **LED indicators** – freely programmable; RGB left LED, green right LED
2. **Functional buttons** – freely programmable

Table 15. Technical data of ABT-EKB-20M microphone extension

Model	ABT-EKB-20M
Power supply	RJ45 from DFMS or DMS
Protection rating	IP 30
Keyboard and controls	
Number of keys	20
Number of LED	20 × RGB + 20 × green
LED color	RGB (red, green, blue) + separate LED green
Other parameters	
Operating temperature	0°C to 60°C
Storage temperature	-20°C to 70°C
Operating humidity	15% to 80%
Storage humidity	5% to 95%
Weight	1,4 kg
Dimensions of the space for the description of the buttons	15 × 25 mm
Dimensions	120 (W) × 55 (H) × 210 (D) mm

7.2.4.1 Functional buttons performance

Every functional button can be associated with any VAS function possible to perform by a button push. The button function is set by program, during VAS system configuration. Depending on the function assigned to the functional button, the meaning of visual indicator signaling changes.

Detailed description of the functions that can be assigned to buttons is given in section 12.10.1 - Functions.

Functions related to alarming and sending messages via microphone:

- » Alarm mode
- » Failure Accept
- » Failure Delete

7.2.4.2 Functional buttons signaling

Function button LED signaling is dependent on the function which is presently assigned to the button.

When the button serves to select a zone, the signaling is as follows:

- » **Message sending indicator:**
 - › Green flashing – when verbal message is sent via fireman microphone “live” in the given zone.
 - › Green constant light – when in the given zone the following is reproduced:
 - In normal mode – verbal message from zone microphone, music background or alarm canceling.
 - › Red flashing – when in the given zone a warning message informing about danger is reproduced.
 - › Red constant light – when in the given zone an automatic evacuation message forcing persons in this zone to leave the plant immediately is reproduced.
 - › Yellow flashing – in case of system failure.
 - › Yellow constant light – when failure was accepted or when one of the zones has been locked (optional function from EN 54-16 norm).
 - › Blue flashing – when intercom communication is requested.
 - › Blue constant light – when intercom communication is activated.
 - › Red flashing – when microphone message is being recorded.
 - › LED steady light – when recorded message is played out.
 - › Cyan flashing – when audio monitoring from the given zone is active.
 - › Magenta flashing – when voice alarm status is delayed (optional EN 54-16 norm, point 7.4).
- » **Availability/zone selection indicator** – green LED lights once the button corresponding to a given zone has been pushed. This indicates that the zone is ready to receive either microphone input or a message saved in system memory.

When the button is associated with failure signaling, the indication is as follows:

- » **Failure indicators:**
 - › Flashing of the microphone extension LED and steady yellow light of the collective failure LED – signals system failure.
 - › Sound signal is generated at the same time (on microphones and Control units with LED displays).
 - › Failure must be confirmed by pressing button next to flashing diode.
 - › Once it has been pressed, the LED light is constant until the failure has been eliminated.

Detailed information can be found in section 8. Operation modes – LED colors.

7.2.4.3 Extension connector

Microphones and microphone extensions are supplied with an aluminum connector.

The ABT-DFMS microphone and the ABT-DMS-LCD microphone should be combined with the ABT-EKB extension with an aluminum connector with the dimensions 136.5x30x3 mm using two M3x8 screws.

The ABT-DMS microphone and the ABT-EKB extension should be combined with the ABT-EKB extension with an aluminum connector with dimensions 124x30x3 mm using two M3x8 screws.

The assembly method is shown in the figures below:

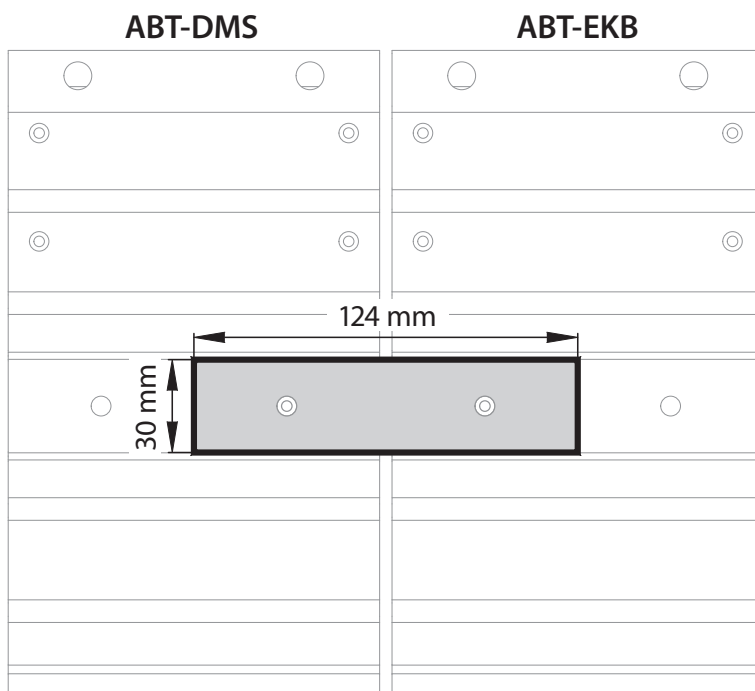
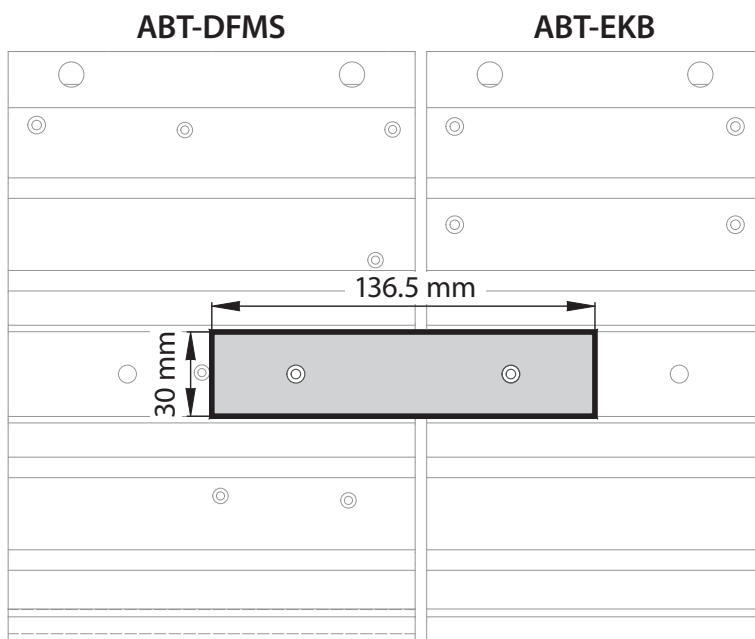

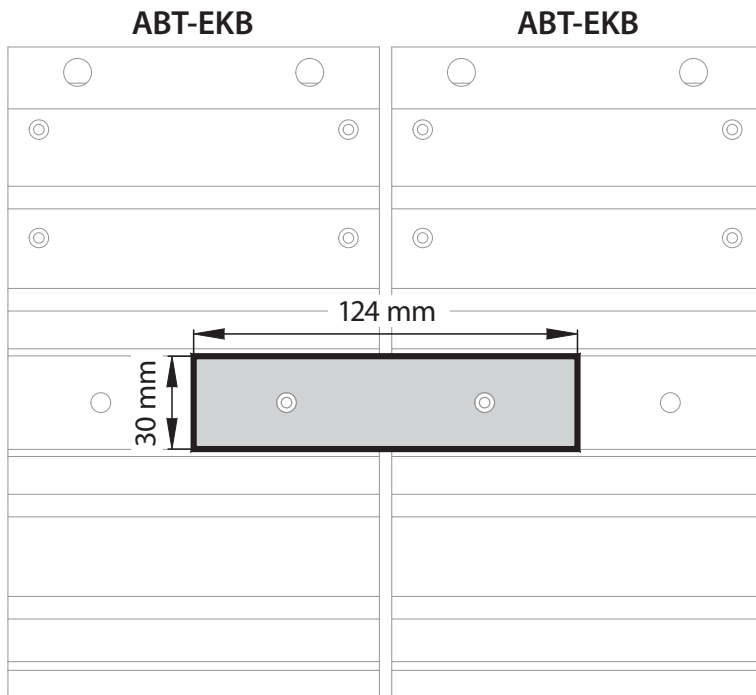
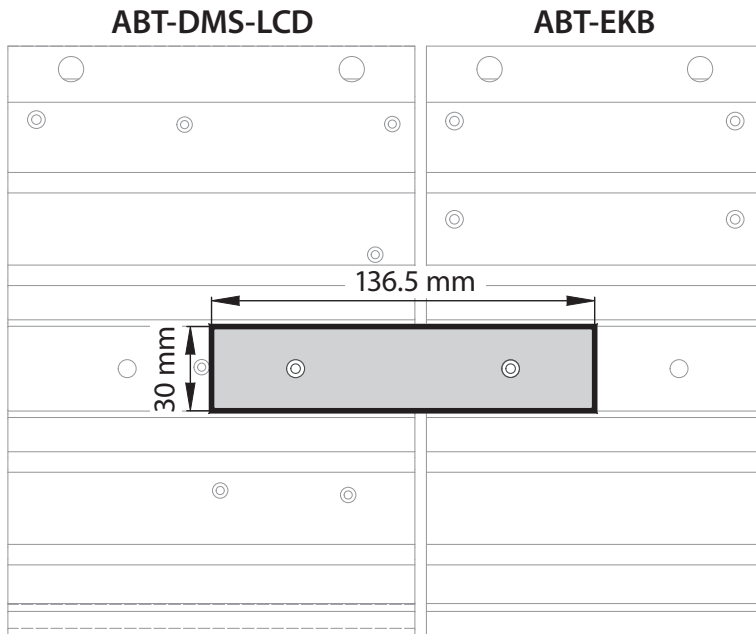

Drawing 57. The way of connecting microphone and extension using an aluminum connector

7.2.5 Noise sensing controller – ABT-NSC6

The background microphone controller is used to:

- » receiving measured signals from 6 ABT-NSM microphones,
- » background noise level measurement and automatic adjustment of emitted audio signal.



Drawing 58. ABT-NSC6 noise sensing controller

ABT-NSC6 is a TCP/IP controller specially designed for the use with MULTIVES and miniVES/midiVES systems. The main roll of the device is collecting audio data from 6 measurement microphones and automatic volume control of background music and announcements in assigned speaker zones. It's adapted to cooperate with ABT-NSM microphones (in speaker housing).

Table 16. Technical data of ABT-NSC6 noise sensing controller

Model	ABT-NSC6
Power source	PoE (RJ45), or by the connector 2-pin Phoenix MSTBVA – 5,08 mm
Number of audio inputs	6 differential channels, connector type 3-pin 15EDGVC-3.5
Power Consumption (typical / maximum)	3,5 W / 6 W
Input voltage range	36 V – 57V
Sampling frequency	24 kHz
Frequency measurement band	200 Hz – 9 kHz @ 3 dB
Differential input impedance	6500 Ω @ 1 kHz
Range of measured values (for input voltages)	57 dB _{SPL} (250 μ V _{RMS}) – 115 dB _{SPL} (200 mV _{RMS})
Phantom power	30 VDC
Temperature (operating)	-5°C to + 40°C
Ingress protection	54 // 66 – with additional packing glands
Enclosure	Aluminium
Weight	1,2 kg
Purpose of use	Ambient noise microphone controller

7.2.6 Moduł nadzoru końca linii ABT-EOL

ABT-EOL monitoruje integralność linii głośnikowej i wszystkich jej gałęzi. Nadzór linii rozgałęzionych wymaga modułu EOL dla każdej z gałęzi. ABT-EOL stanowi selektywne obciążenie wyłącznie dla tonu pilota o częstotliwości 20 kHz. Moduł końca linii zwiększa niezawodność metody nadzoru głośników opartej na pomiarze impedancji. Moduł łączy się równolegle z ostatnim głośnikiem na linii. Posiada 4 różne tryby, które należy wybrać zgodnie z wynikami obliczonymi przez kalkulator EOL.

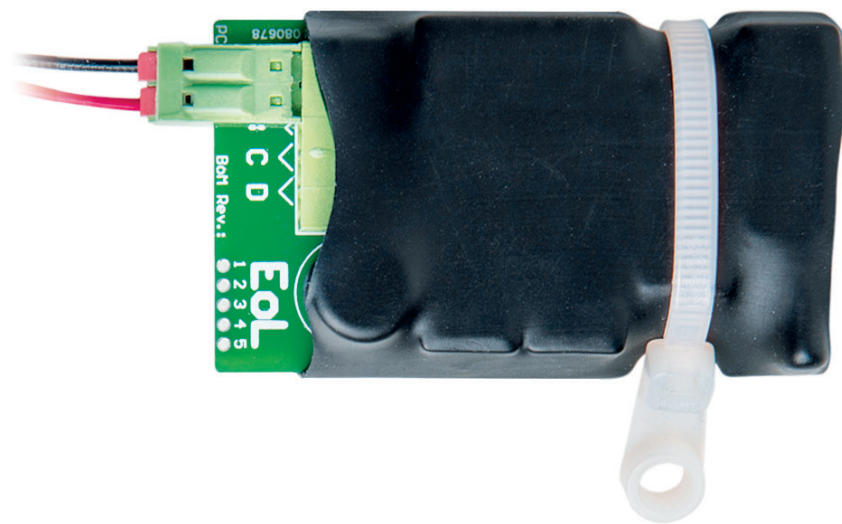

Drawing 59. Moduł nadzoru końca linii ABT-EOL

Table 17. Dane techniczne modułu nadzoru końca linii ABT-EOL

Model	ABT-EOL
Rodzaj	Moduł końca linii dla linii głośnikowych
Złącze	Phoenix typ 3,5 mm; 5 pinów
Napięcie	100 V linia głośnikowa
Obsługiwane obciążenie	10 W – 480 W *
Temperatura pracy	-10°C do 55°C
Temperatura przechowywania	-40°C do 70°C
Wilgotność względna	< 95%
Wymiary	65 (dł.) × 16 (wys.) × 37 (szer.) mm
Montaż	Wewnątrz głośnika / opcjonalna puszka instalacyjna
Waga	ok. 46 g / komplet 10 modułów – 500 g

* Tryb podłączenia wyznaczony przez konfigurator EOL calculator

7.2.7 ABT-M01 Microphone

The ABT-M01 microphone is an affordable fully analog device. It is equipped with a built in gong generated onboard the device, accessible through the switch on the back panel. The gong as well as the microphone itself has an individual volume control knob also placed on the back panel of the device. To operate the device press the **MIC ON** button, the status LED will switch to steady green light. In the event of an active built in gong, the status LED will turn green once the gong has ended. When finished transmitting the message release the **MIC ON** button to deactivate the gooseneck mic.

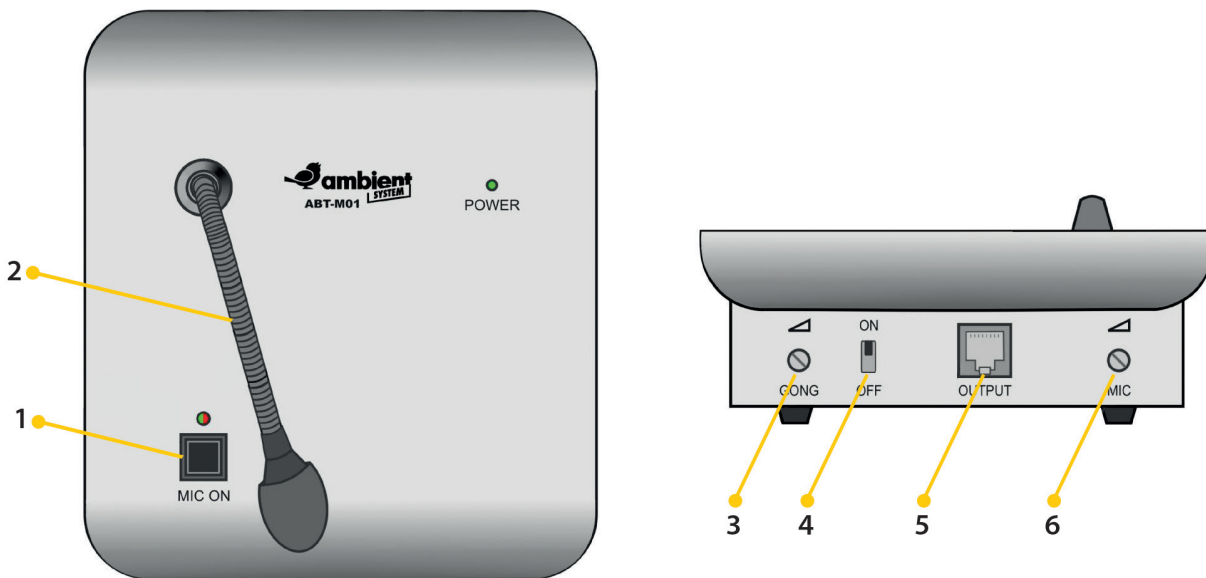

Drawing 60. ABT-M01 main control placement

1. **MIC ON button**
2. **Dynamic gooseneck microphone**
3. **Gong volume knob**
4. **Gong ON/OFF switch**
5. **RJ45 output connector**
6. **MIC volume (gain) knob**

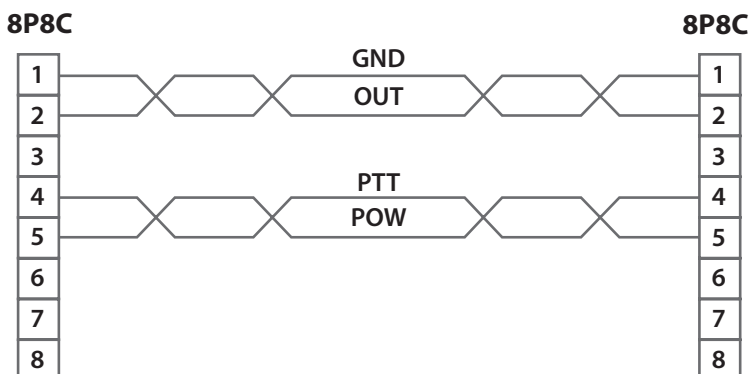

Drawing 61. Microphone Connector pinout

Connection Diagram

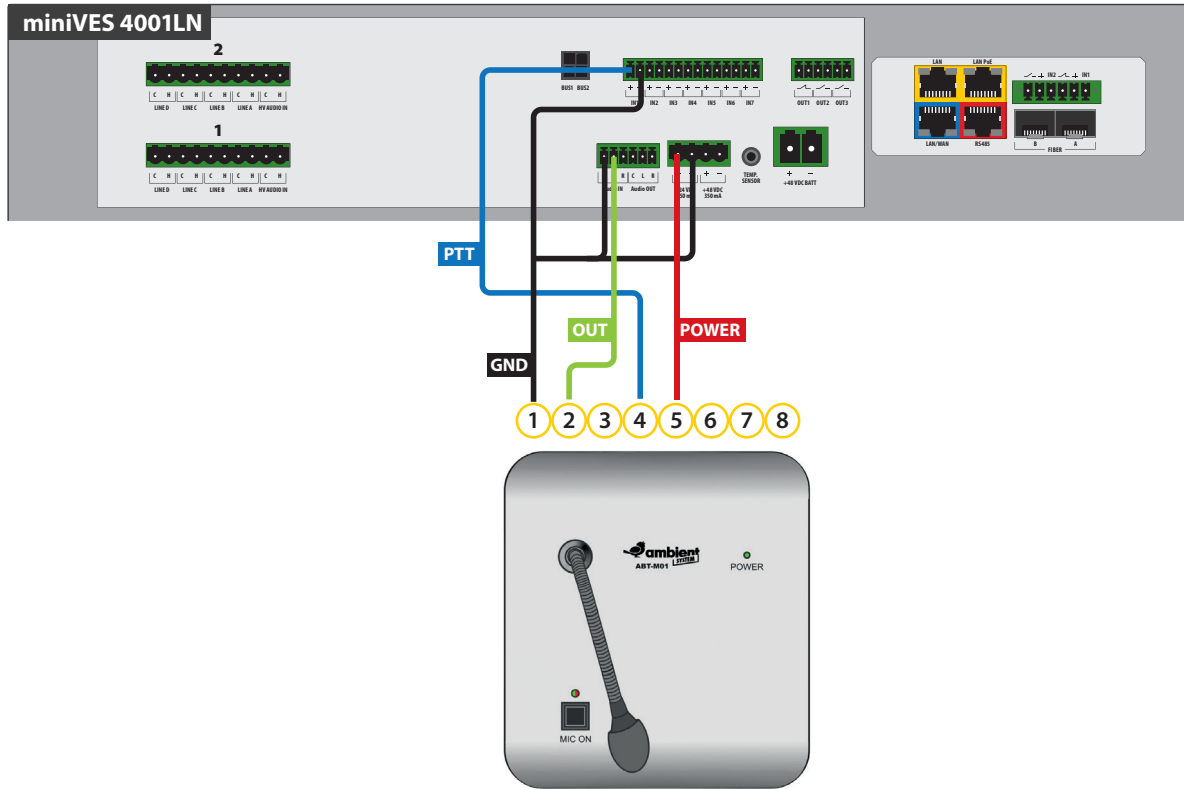

Drawing 62. Connecting the ABT-M01 microphone to miniVES

miniVES settings

- » Change the generic name of the Audio input no.3 to **Local Audio IN**
- » Create a Zone group – **All Zones** and add all of the available zones
- » Create a new matrix and name it **Microphone** – add the **Local Audio IN** input from the available **Audio inputs field** and the **All zones** zone group
- » In the **Events Configuration** tab assign the following events to Logical input INPUT1, contact mode:
 - › **Active – General** – add the **Microphone** matrix (start)
 - › **Inactive** – add the **Microphone** matrix (stop)

Table 18. Technical data of ABT-M01 microphone

Model	ABT-M01
Efficiency, mV / Pa	10
Output level, mV	775
Maximum distance from amplifier, m	250
Recommended cable type	UTP
Connector Type	8P8C (RJ45)
Dimensions without packaging (not more than), mm	150 × 60 × 165
Net weight (not more than), kg	1,2

8. System hardware installation

8.1 Information on limiting damage consequences

In order to avoid problems with Voice Alarm System Central Unit, it is advisable to get familiar with the contents of this manual before the first use of the central unit.

VASCU is equipped with a set of automatic functions which are responsible for testing system efficiency. FAILURE diode signals abnormalities. In such case, it is necessary to take prompt actions and, if necessary, consult a person in charge of VAS efficiency.

8.2 General connection diagram

Network connection of separated central units and fireman microphones by means of a fiber optic loop:

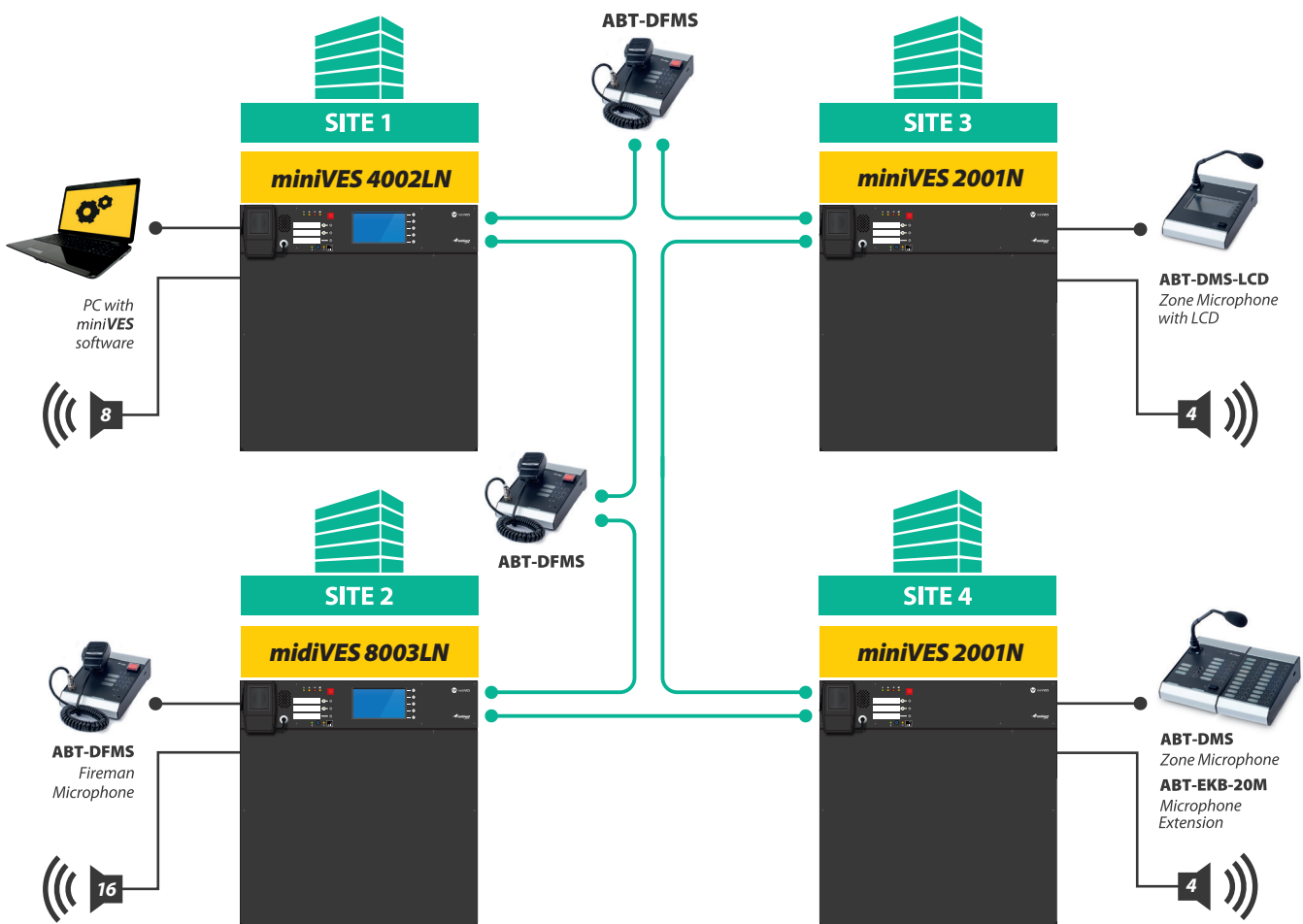

Drawing 63. General connection diagram

8.3 Connecting devices

The miniVES central unit can be either placed in a RACK cabinet or used as a stand-alone wall mounted system. In the case of rack mount use, the cabinet should be IP30 rated (according to EN54-2) and should be fitted with cooling fans.

In order to assure compliance of VAS central unit with norms, connections:

- » with fire signaling central unit,
- » sources of power,
- » fireman microphones,
- » network infrastructure,
- » other VASCU elements,

must be carried out by suitably-trained and qualified personnel in accordance with relevant directives for electric devices.

⚠ NOTE: It is crucial to connect the batteries to the system before startup.

Once the power supply has been provided, connect loudspeaker lines, logic inputs and outputs, network devices.

When you make sure all connections have been carried out properly, you can power up the system.

8.3.1 Control units

This section presents examples of control units connection diagrams.

8.3.1.1 Daisy Chain Topology

In CHAIN topology, the connection is not redundant. Connecting units in this system does not guarantee operation of the system in the event of communication cable damage. According to EN 54-16 norm, connections between VAS control units in a large scale system must be redundant. Connections in CHAIN Topology are applied locally, and in the systems not responsible for sending evacuation messages.



Drawing 64. Example of CHAIN topology control units connection

The connection between the units (miniVES / midiVES and system microphones) can be made using 2 wires (not twisted). This requires the use of two CTC VDTU2-B140-DC converters in Remote and Master configuration and an additional 48VDC to 24VDC converter.

8.3.1.2 Power and Lan Configuration

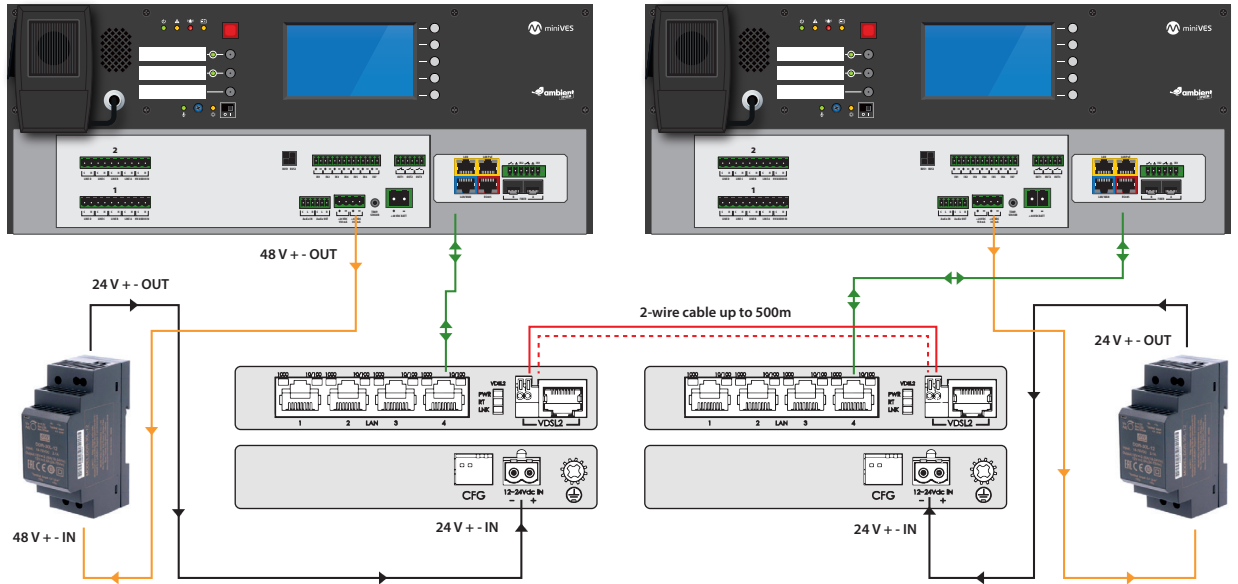

Drawing 65. Example of power and lan configuration

8.3.1.3 DIP Switch Configuration

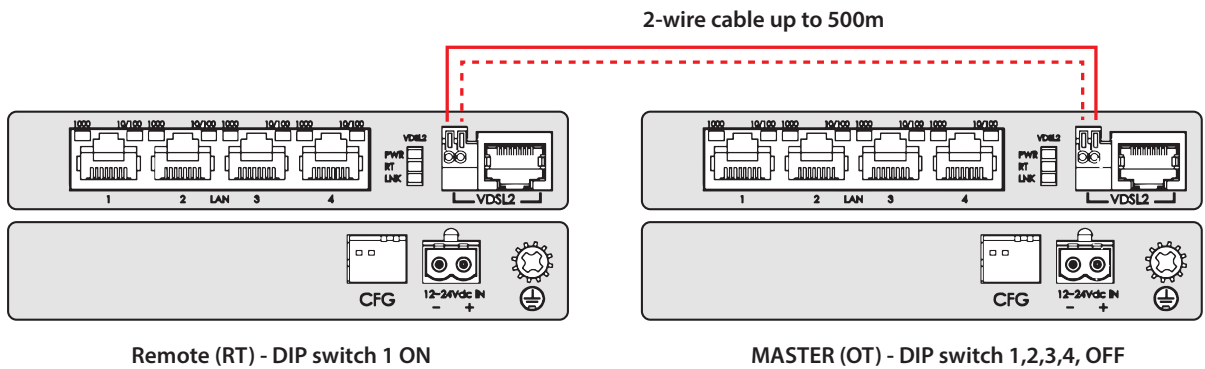

Drawing 66. Example of DIP Switch Configuration

Model	DIP Switch				Symmetrical/ Asimmetrical	G.INP/ Interleaved Mode	Target SNR Margin (dB)	Max Data Rate DS/US (Mbps)
	1	2	3	4				
Master (OT)					Symmetrical	G.INP	8	160/160

Remote (RT) will always follow the setting of Master Unit (OT). When the unit operates in RT (CPE) Mode, DIP Switches 2,3,4 have no function.

8.3.1.4 Use of CTC VDTU2-B140-DC

- When microphones or Cu units are more than 100m away.
- TCP / IP over cat3 cable or 2-wire straight cable.
- Up to 150Mb/s over 500 meters.
- Compatible with Multive / miniVES cat 5 to SFP modules.



8.3.1.5 Example of Use with Systems - Point to Point Connection

- For small systems (1x CU) all 4- ports can be used.
- Middle size systems up to 5x CUs and 20x IP microphones 500 meters connection over HTKSH 1x2x1.4 max 2-ports can be used.

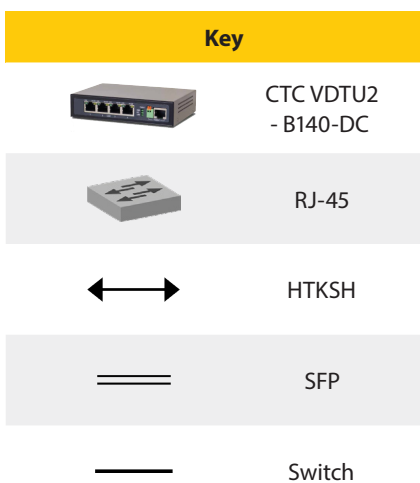

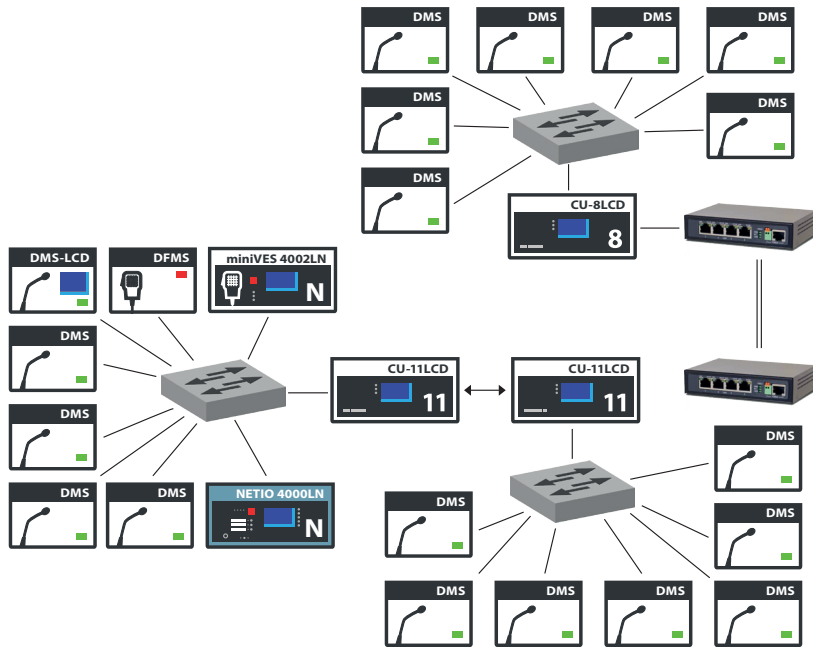

Drawing 67. Point to Point Connection Example 1

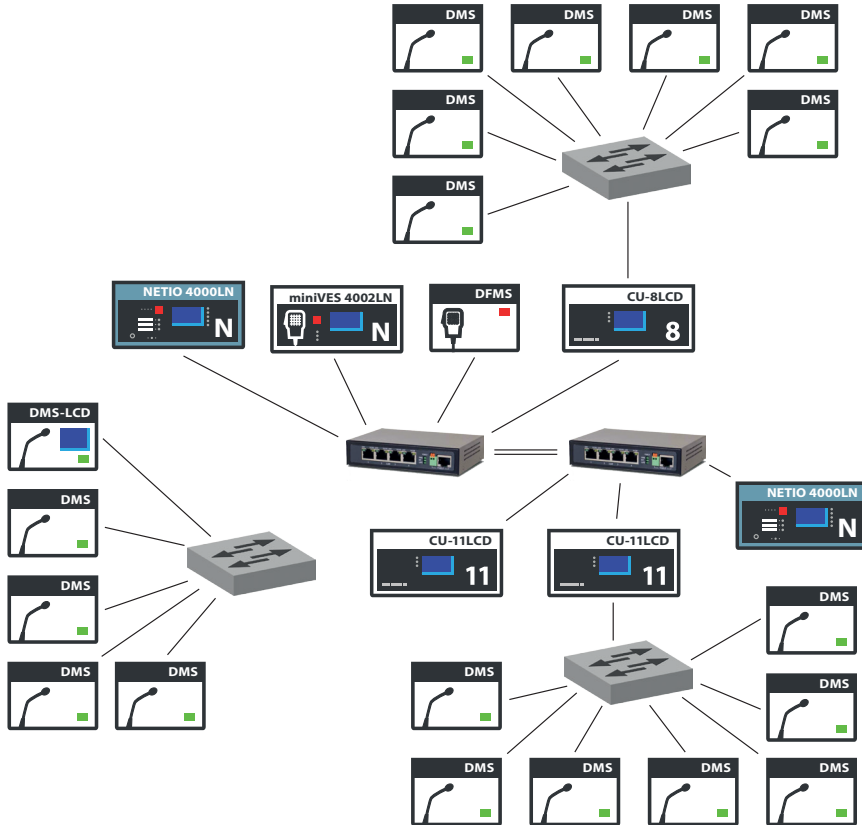

Drawing 68. Point to Point Connection Example 2

8.3.1.6 Ring Topology

In RING topology, the connection between system elements is redundant. The cables form a single continuous pathway for signals through each node – a ring. In the event of cable/communication optic fiber damage, the system still functions by using the remaining part of the ring.

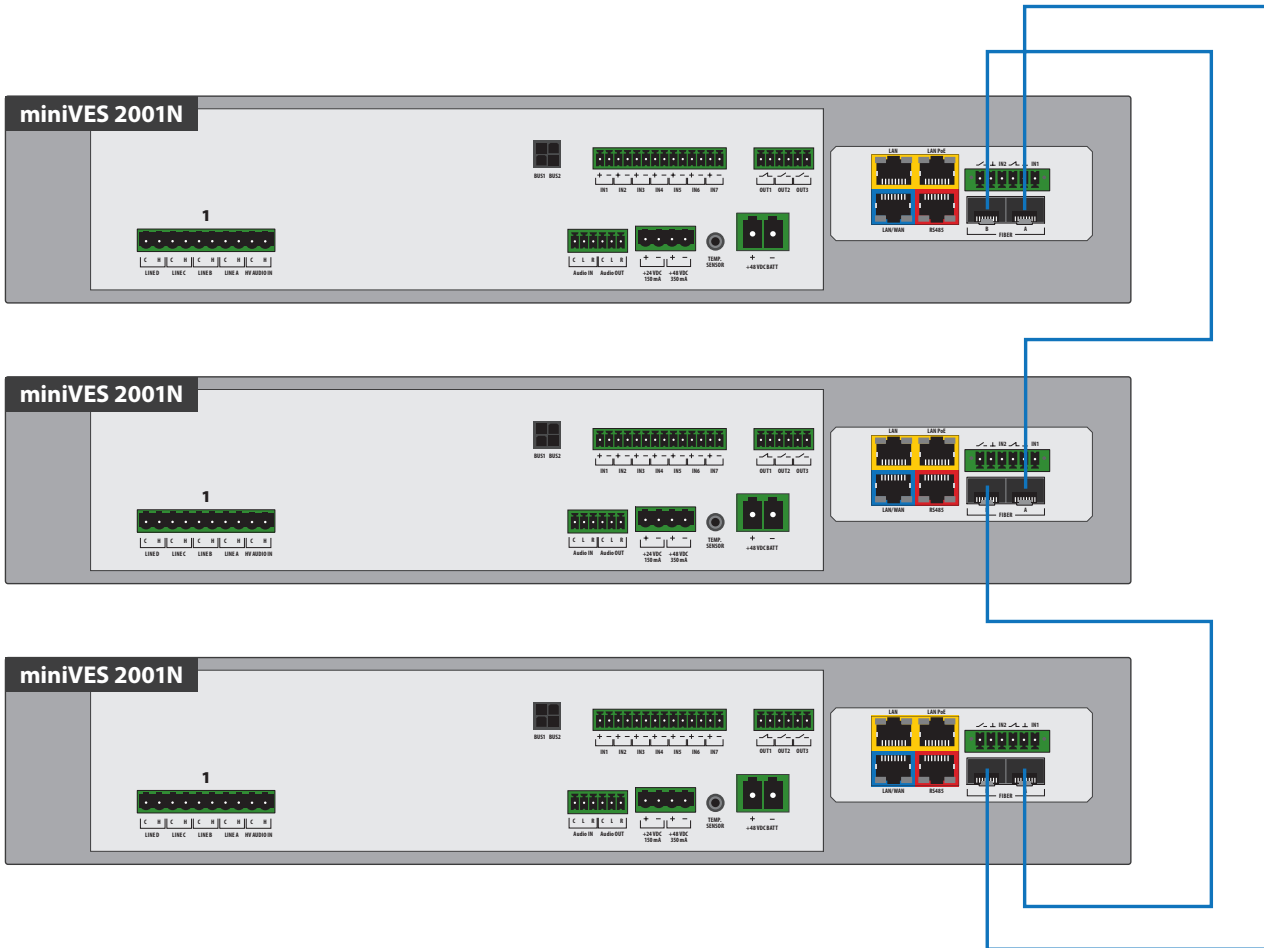

Drawing 69. RING topology control units connection (fiber connection)

Note: this connection type applies only to xxxxN and xxxxLN series units. These devices are equipped with the xNET_mini 1Gb/WAN/RS network card providing slots for two SFP modules.

The connection between the units (miniVES / midiVES and DFMS) can be realized over 2 wires in a redundant manner using the loop topology available on SFP modules. This requires two SFP-1GBT-06 or SFP-CP100C-GP modules and two VDTU2-B140-DC CTC converters for each unit. The SFP A port on unit 1 is connected to the VDTU2 converter set as Remote via a Cat5e cable, then via a pair of wires it connects to the second converter set in the MASTER mode, which is connected to the SFP B module on the device no.2 via a cat5e cable. The connection should be restored for SFP B on device No. 1 and SFP A on device No. 2.

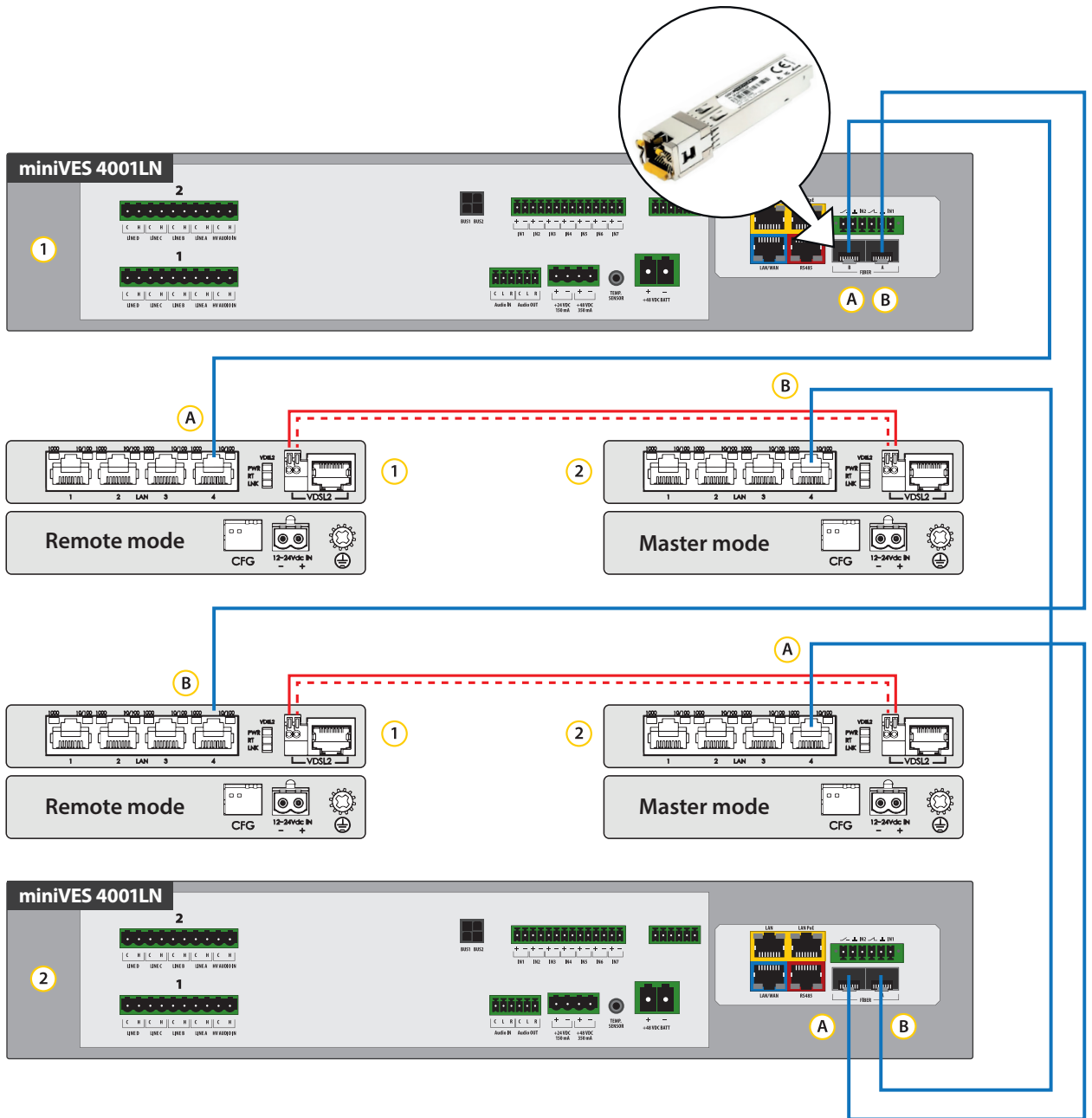

Drawing 70. RING topology control units connection (copper connection)

8.3.2 Batteries

It is necessary to protect batteries from short-circuit while connecting battery leads. Short-circuit may lead to system failure. Follow this manual to assure safety while connecting.

Make sure the system power has been switched off before battery is connected.

Once the batteries have been connected, make sure all terminals of all batteries have been protected against short-circuit.

Connecting batteries

- » Wait over 10 seconds after the power cord was unplugged from AC socket located on the miniVES main unit.
- » Never connect negative cable in the first place as in the case of short-circuit between battery positive wire and a device frame or rack cabinet element, a device damage may occur.
- » Connect battery negative cable to negative terminal.

Disconnecting batteries

- » Make sure battery supply is not used. To do so, check LED on the miniVES front panel which signals such state of affairs.
- » Take out battery negative lead from terminals. Never disconnect positive wire in the first place as it may cause short-circuit if you touch device frame or rack cabinet elements. Isolate disconnected cable tip with a suitable insulator, e.g. insulating tape, to protect against short-circuit.
- » Disconnect last battery lead. Isolate disconnected wire tip with a suitable insulator, e.g. insulating tape, to protect against short-circuit.

⚠ A total voltage of batteries connected to the device, loading and monitoring, according to EN 54-4 should reach 48 VDC (40-56 VDC). In the last stage of system commissioning, it is necessary to connect four VRLA 12 V batteries to the battery port located on the main connector panel of the miniVES unit via the provided cable with special regard to wire polarity. Additionally, it is necessary to connect a thermistor temperature sensor by connecting its wire to Temp Sensor connector and placing the sensor in the place where the batteries were installed.

⚠ NOTE: battery bank has to be connected before connecting main power supply.

**⚠ In case of disconnecting batteries and lack of AC power please wait 60 seconds for fully discharge of miniVES before the battery pack will be reconnected to the system.
Improper connection procedure may lead to charger module damage.**

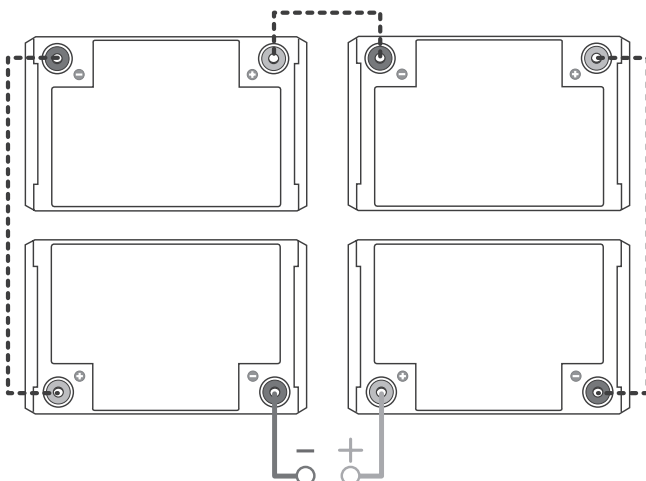

Drawing 71. 4x12 V DC VRLA storage batteries connecting diagram

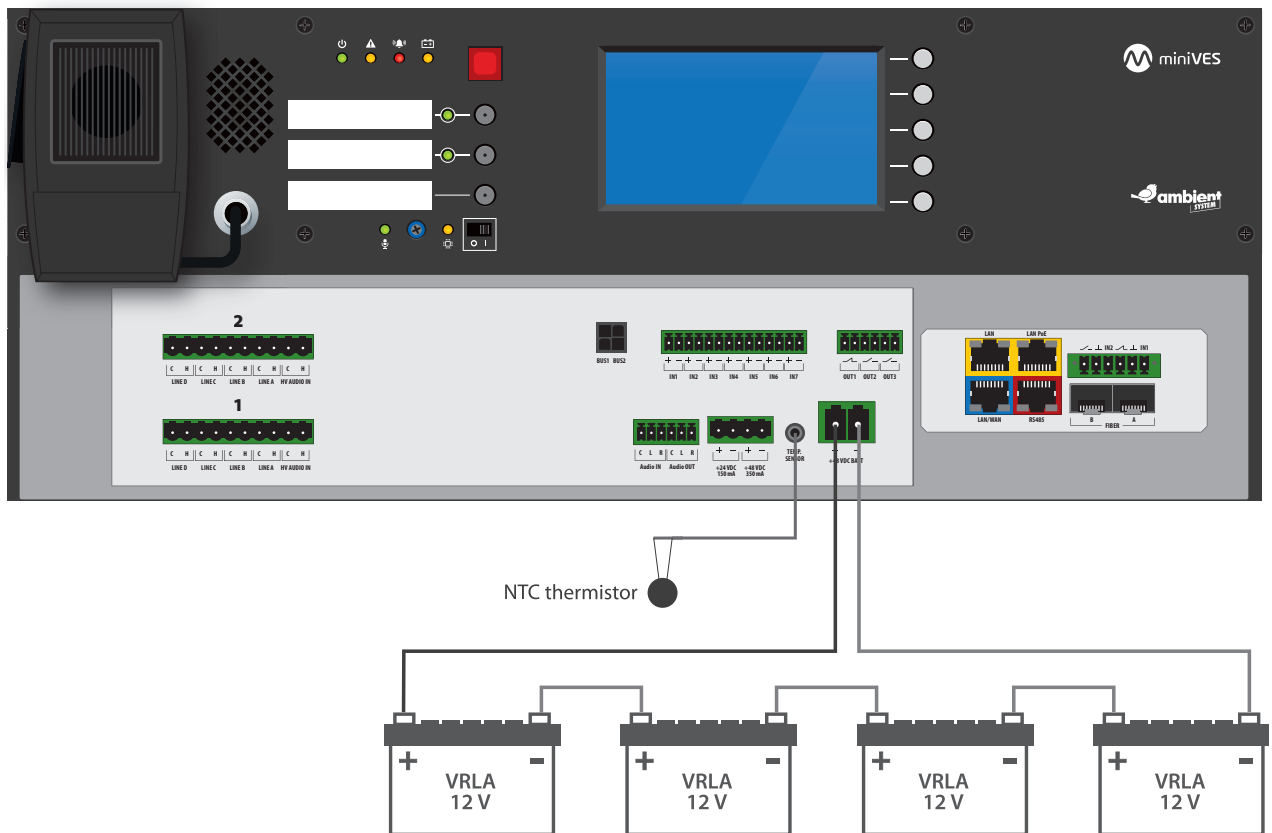

Drawing 72. Battery connection diagram

Thermistor installation:

A thermistor, attached to a 3.5 mm jack on the connector panel of the miniVES / midiVES unit is intended to compensate temperature changes when charging batteries. Place the thermistor between two batteries.

NOTE: the thermistor cable can be extended by several meters without any risk of communication loss

Before powering up the miniVES / midiVES unit for the first time, it is necessary to perform standard inspections specified in the chapter – *Maintenance and service* – page 112.

8.3.3 Microphones

8.3.3.1 Fireman microphone RING-type optic fiber connection

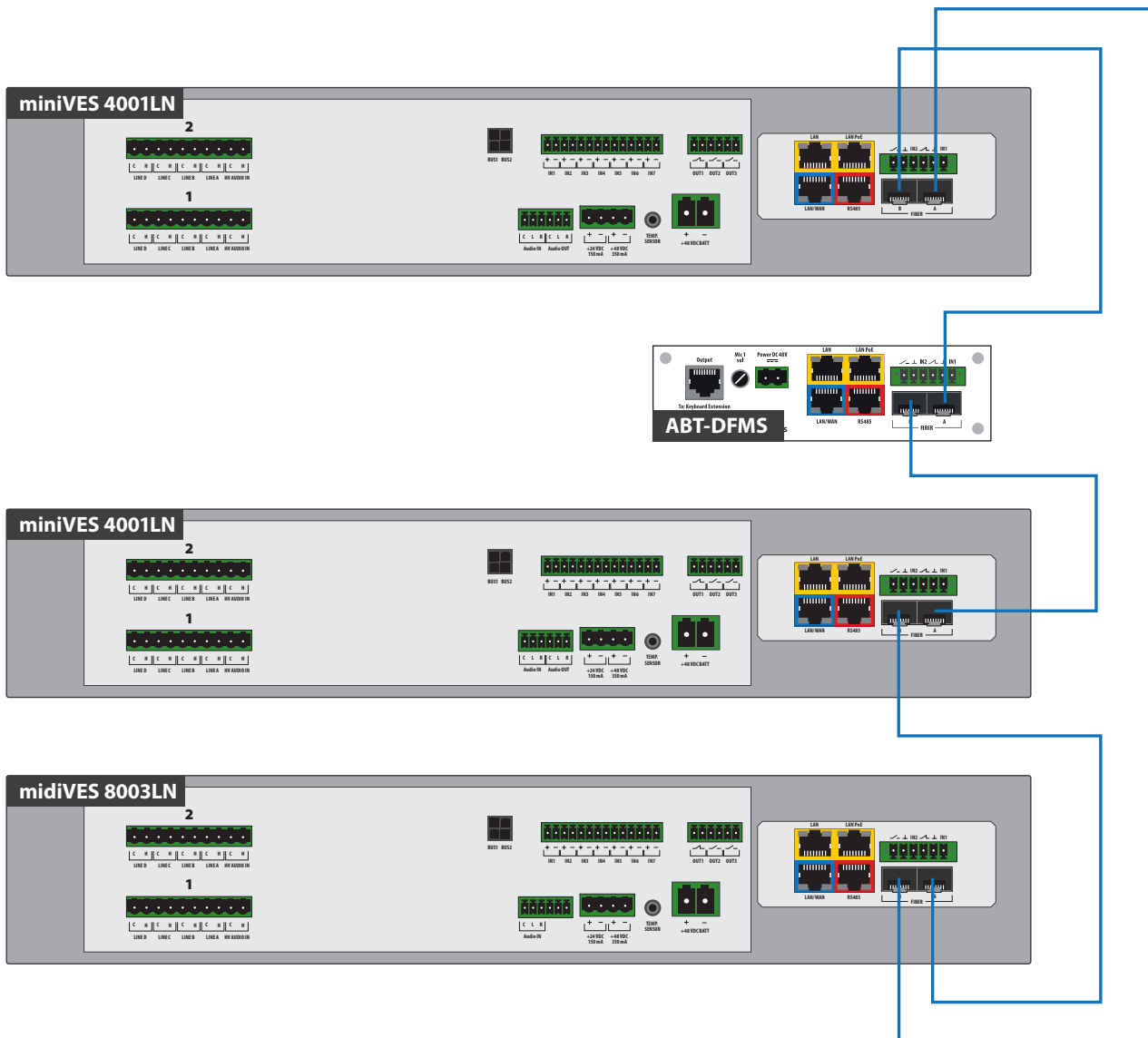

Drawing 73. Fireman microphone optic fiber connection – RING topology

8.3.3.2 Fireman microphone CHAIN-type cable connection

In the CHAIN-type cable connection, the first fireman microphone can be connected to the control unit via LAN PoE, whereas further microphones require external power supply. This does not apply to a system in which there are PoE switches between microphones (Switches must be supplied with fire power supply units).

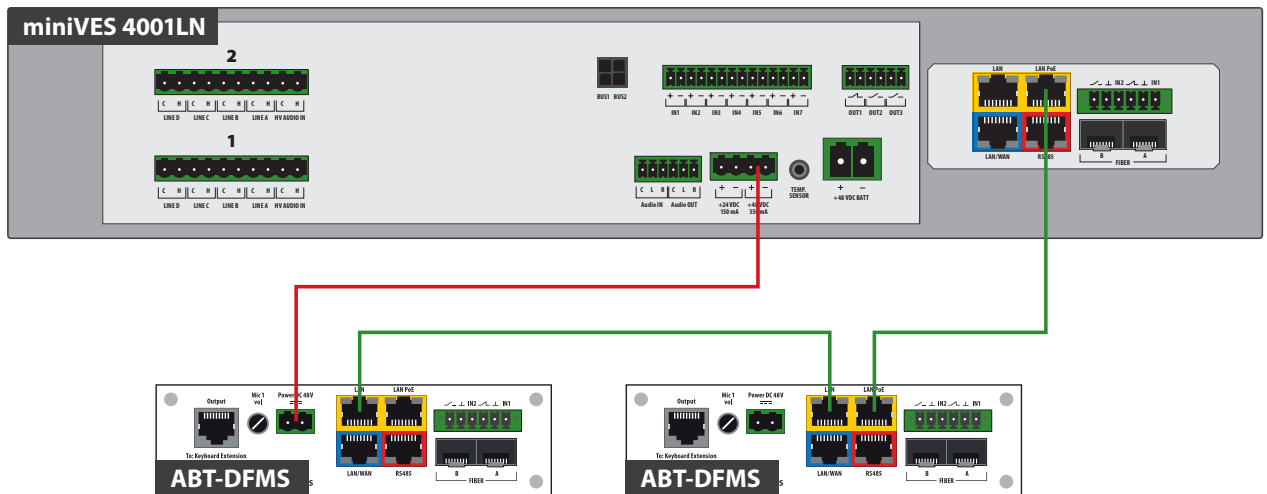

Drawing 74. Fireman microphone cable connection – CHAIN topology

8.3.3.3 Different ways to power the fireman microphone

1. Via LAN PoE in miniVES Control Units

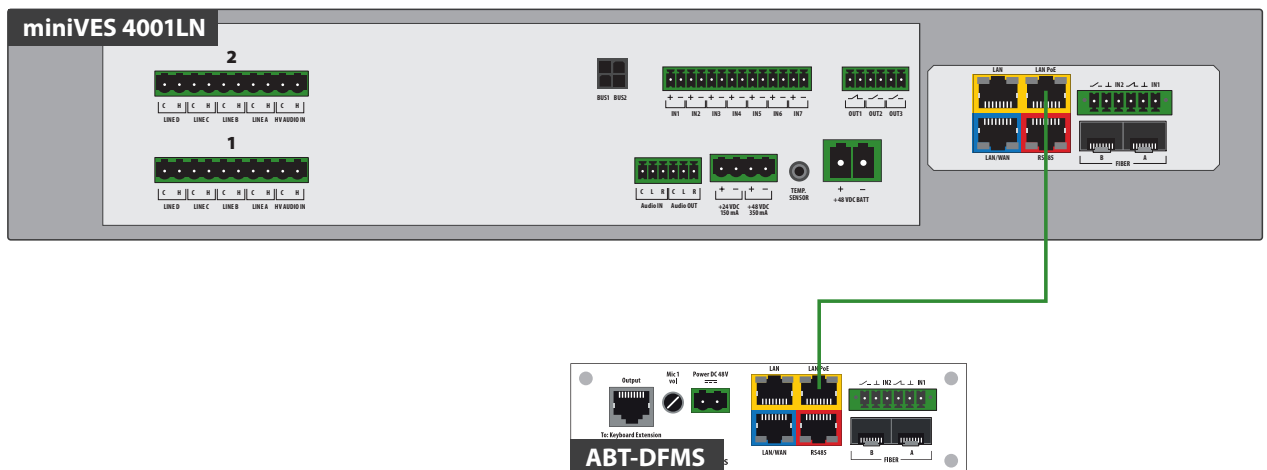

Drawing 75. Fireman microphone powered through LAN PoE

2. Via auxillary power connector located on the main panel of the miniVES unit

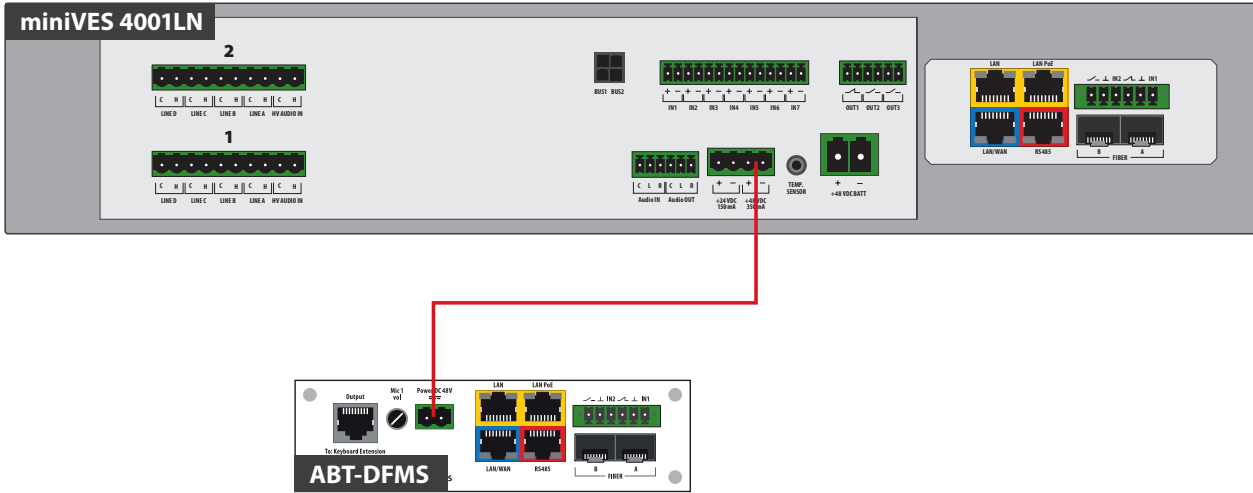

Drawing 76. Fireman microphone powered from 48 V auxillary power output

3. Via external fire power supply unit 48 V

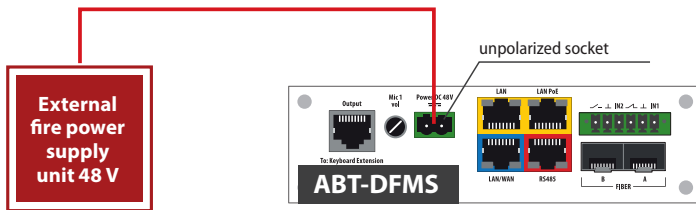

Drawing 77. Fireman microphone powered by the fire power supply unit

8.3.3.4 Zone microphones – types of connection

A zone microphone can be connected directly to VASCU via LAN or to the fireman microphone. Most zone microphones can be connected to VASCU via a certified switch. When the switch supports PoE function, only one wire (UTP/STP cat. 5e) is required to assure a proper microphone operation.

1. LAN PoE connection.

For direct connection to VASCU, it is not required to provide additional power supply provided that the unit has LAN PoE port.

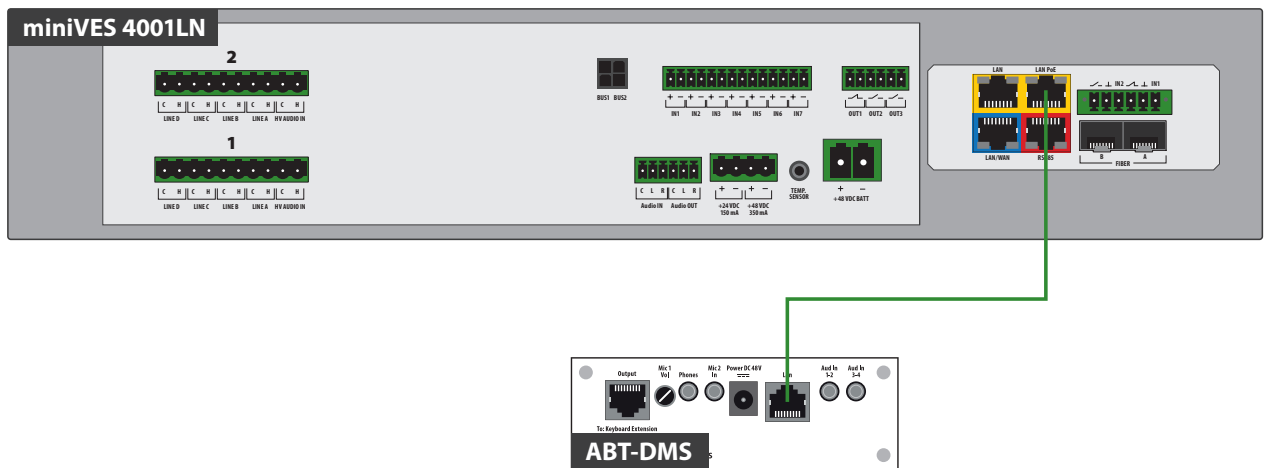

Drawing 78. Connecting zone microphone

2. Connecting via ABT-DFMS fireman microphone. In this case it is required to provide additional power supply from the external power supply unit or the auxiliary 48 V power output on the miniVES unit.

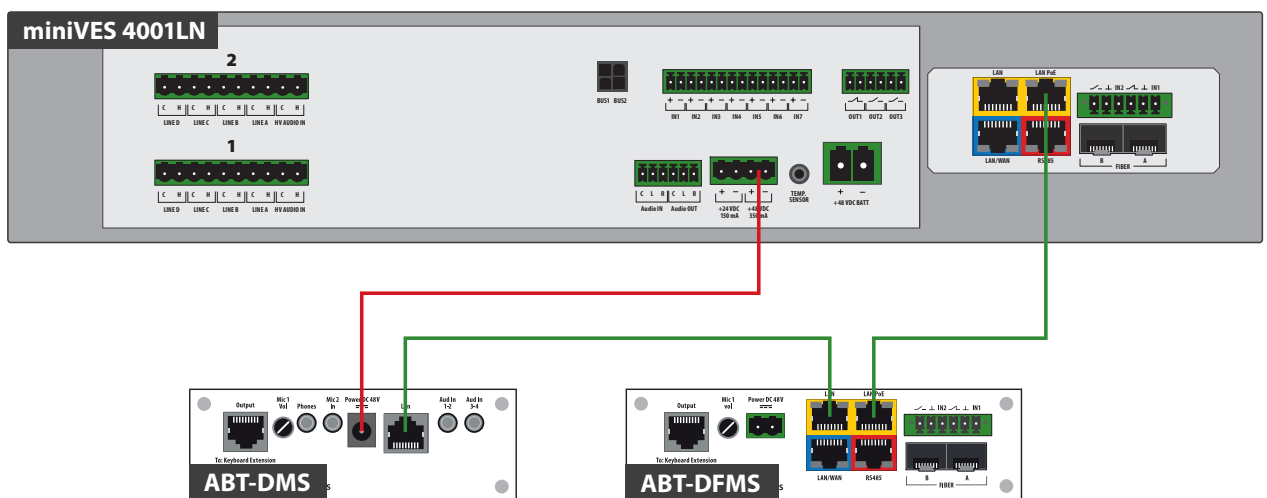

Drawing 79. Connecting zone microphone, fireman microphone

3. **Connecting with a certified network switch.** The diagram below shows connection of 4 zone microphones via a switch with LAN PoE.

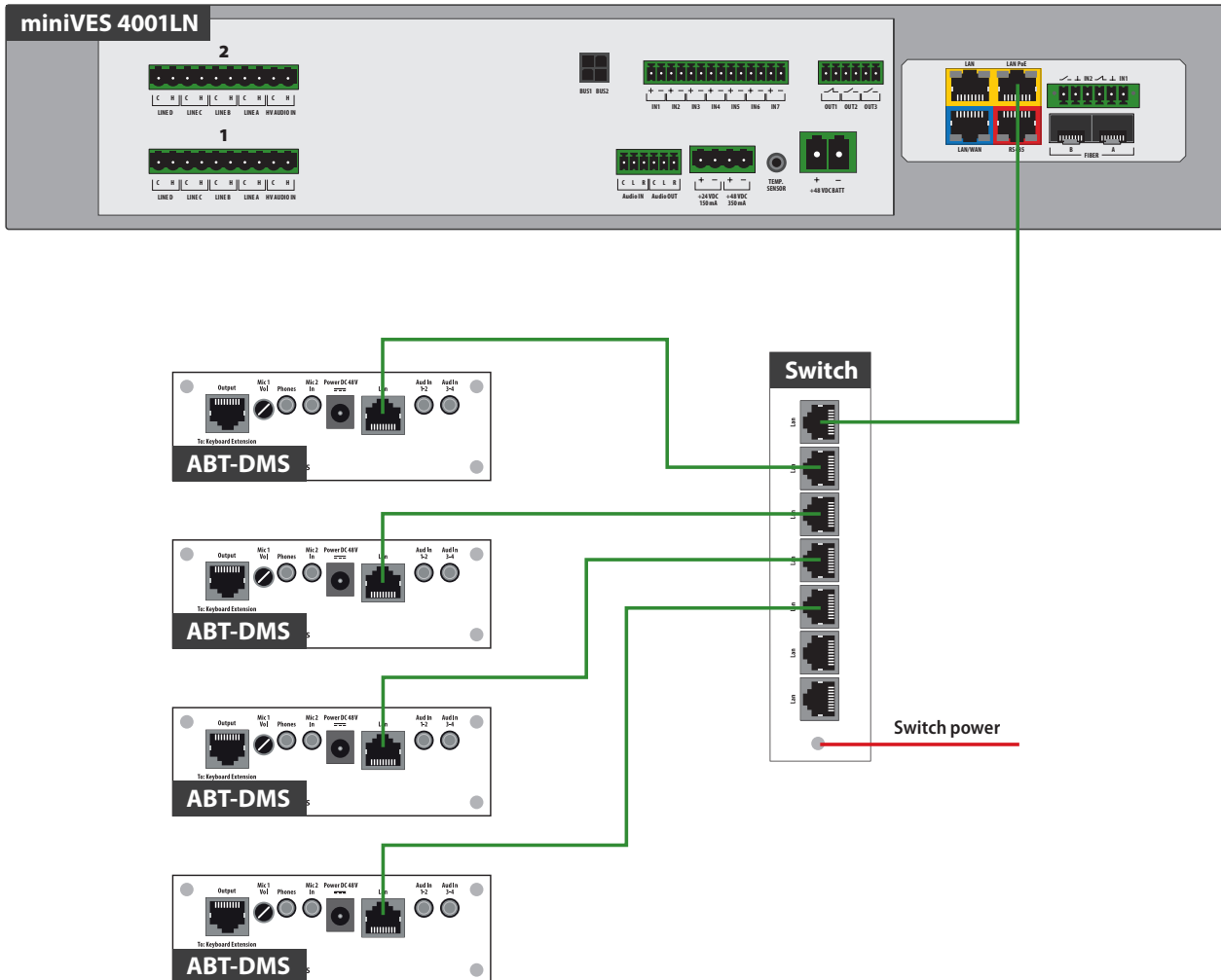

Drawing 80. Connecting zone microphone – switch

List of certified switches:

- » NETGEAR – Prosafe Gigabit Plus series with PoE
- » CTC Union Technologies – IGS Gigabit Ethernet Managed Switch series
- » CTC Union Technologies – IFS Fast Ethernet Managed Switch

8.3.3.5 Connecting power to zone microphones

Zone microphones can be powered either locally (48 V) or from the miniVES central unit with PoE.

Ways to power a zone microphone:

1. Via LAN PoE (from VASCU or certified switch)

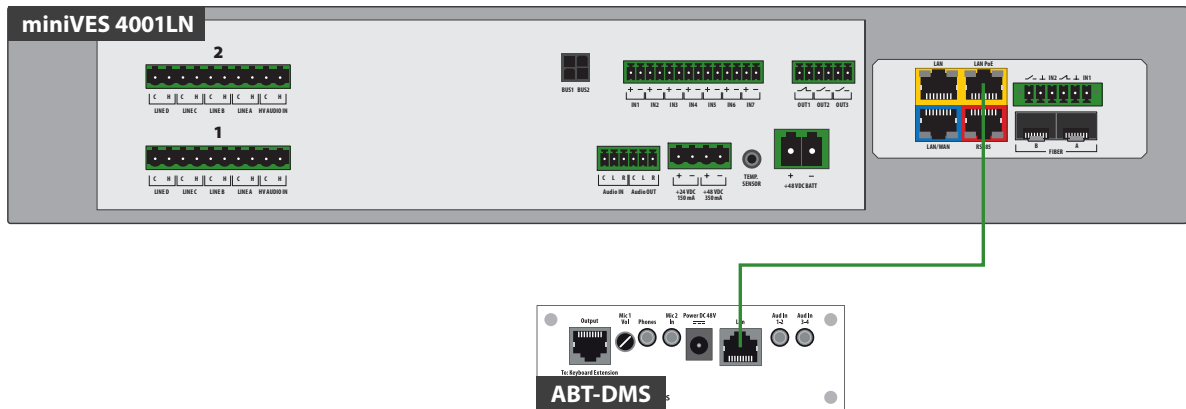

Drawing 81. Zone microphone powered by LAN PoE

2. Via auxillary 48 V power output on the connector panel of the miniVES unit

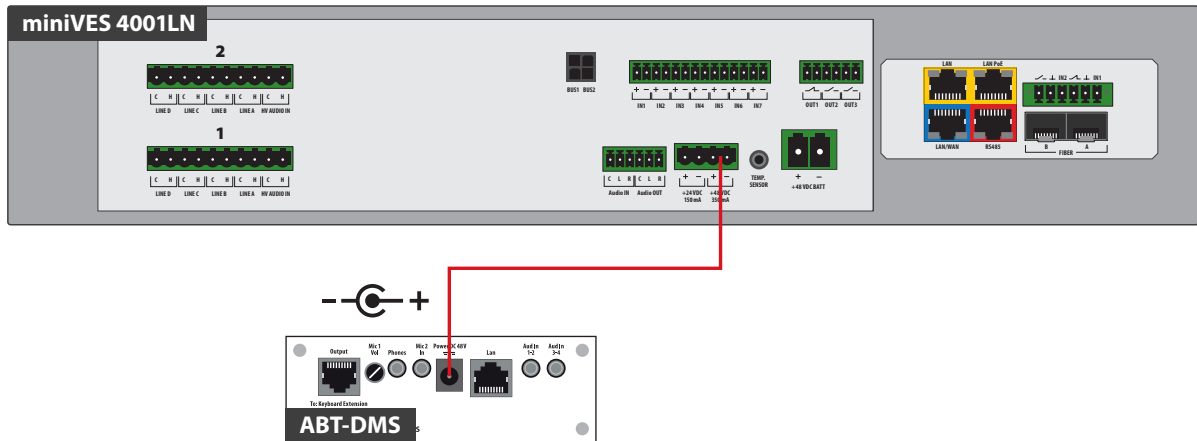

Drawing 82. Zone microphone powered by the auxillary 48 V power output on the connector panel of the miniVES unit

3. Via external power supply unit 48 V

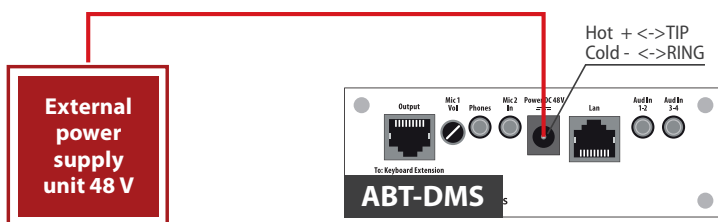

Drawing 83. Zone microphone powered from an external source

8.4 Preparing sound system for VAS application

Cabinet assembly

Carefully mark loudspeaker line cables, control cables and power cables. Upon routing the cables provide at least 3 m of margin, measured from the floor. Anticipate empty service space behind the cabinet (at least 50 cm from the wall). Make sure there is a gap between the back of the cabinet and the wall.

Messages recorded on memory cards

Define content, language and type of recorded messages on memory cards. (Emergency messages should suit the building and be confirmed by the Fire Marshal). To record messages, please contact Ambient System Sp. z o.o. employee who is responsible for VAS start-up.

Emergency messages:

- » **EVACUATION** – potential life hazard requiring evacuation – the message instructs all inhabitants to leave the building immediately,
- » **WARNING** – situation in which danger is imminent and requires warning during evacuation,
- » **CANCELLATION** – information that the alarm has been cancelled and there is no danger on the site,
- » **NO HAZARDS** – operational messages, e.g. system testing.

Fire scenario and control between FACIE and VAS

Please prepare a fire scenario which involves an algorithm of cooperation between SAP and VAS systems. (This algorithm should be accepted by the Fire Marshal). Make sure that a sufficient number of cable connections is made between the FACIE fire signalling central unit and the VAS cabinet to allow triggering of the evacuation message and reporting error state. When connecting the FACIE central unit to VAS, fire resistant cables with the rating of at least PH30 must be used. As for control algorithm, please consult Ambient System Sp. z o.o. employee responsible for VAS start-up.

Loudspeaker lines

Please check if the loudspeaker lines have been routed in accordance with the blueprint the number of loudspeakers per single line, selection of the correct power on speaker transformers, proper line description compliant with the blueprint). Use the meter (e.g. ohmmeter or multimeter) to check for short-circuits between loudspeaker line and earthed elements. Next, check for short-circuits or open-circuits between loudspeaker line wires.

⚠ While assembling loudspeakers, the wires must be connected to the tap of the speaker transformer corresponding to the correct power as specified in the blueprint. Incorrect power setting can lead to amplifier overload. In the process of system startup, it causes unwanted time and resource loss.

Power supply

The miniVES units accept Single-phase 230 V AC power. While connecting the power supply, make sure that each unit is provided with a separate circuit and choose proper means of protection.

The cable supplying the miniVES unit with current should bypass the site's main power switch. (Use at least 3 × 1.5 fire resistant cable with PH90 rating). The power cord must be led to the target place where VAS cabinet is assembled. The cabinet power supply circuit must be protected with a residual current device.

System start-up by Ambient System Sp. z o.o. employees

The sound system must be prepared according to the instructions above. Before the team responsible for VAS system start-up arrives, send the email to serwis@ambientsystem.pl with information that “system is completed and ready for start-up” along with start-up date. Make sure the technicians have access to the room intended for VAS cabinets, reduce the number of third parties at the time when the system is installed. It is strictly forbidden to perform any works in the VAS assembly room by personnel unauthorized to install VAS cabinet. Once the system has been started, conduct a training related to system operation for staff responsible for proper system use, and prepare relevant protocols.

Speech comprehensibility testing

Pursuant to provisions of EN 60849 norm, each Voice Alarm System (VAS) installation must be followed by speech comprehensibility tests. These tests aim to confirm that the installed sound devices are able to produce a suitable acoustic power which allows obtaining a required sound pressure level (SPL), as well as a high degree of RASTI speech comprehensibility – in accordance with assumptions in the specification. The tests must be performed on a system operating in alarm mode and without the use of dynamic range compressors.

The scheduled system test must be arranged with staff responsible for administration of the building and Ambient System Sp. z o.o. employee. Make sure to provide access to rooms in which tests are supposed to be carried out (as a rule – all rooms in the building). Please notify personnel staying in the building (i.e. plant administrator) that tests will involve unpleasant and noisy signals emitted by loudspeakers.

9. Operation modes – LED colors

LED indicators located on microphones and control units can signal various statuses. The tables below present the indicators and their functions.

Table 19. Colors signaling on the system microphones depending on the function assigned

FUNCTION	LED 1		LED 2				
	GREEN		RGB			Blink	On
	Blink	On	R	G	B		
General	✓						
Stop Scenario	✓						
Skip Scenarios Delay	✓						
Audio Monitor	✓	✓					
Volume Change	✓						
Failure Accept	✓						
Failure Delete	✓						
Alarm Mode	✓	✓	●				
Display Text	✓						
Led Test							
Select Audio Source	✓	✓					
Mute Audio Source	✓	✓					
Select Zone	✓	✓					
Block Zone	✓	✓					
Zone(s) OFF	✓						
Group Zone	✓	✓					
Start/Stop Matricing	✓	✓					

Power Safe	✓	✓		●	●		
Scenario Delay	✓		●		●	✓	
Silence		✓	●				
Intercom					●	✓	
Record Message			●	●		✓	
Failure Delete	✓		●	●		✓	
Failure Accept	✓		●	●			
Standby	✓	✓		●	●	✓	

Table 20. LED colors of the button assigned to the function Select Zone

FUNCTION	R	G	B	Blink	On
Block Zone	●	●			✓
Zone failure <ul style="list-style-type: none"> › short-circuit / ground fault / opening › impedance failure › switch to B side of the loop 	●	●		✓	
Zone failure confirmed	●	●		✓	
Emergency message playback	●				✓
Warning message playback	●			✓	
Voice message from a fireman microphone		●		✓	
Voice message (from a zone microphone, BGM)		●			✓
Service message playback			●		✓
Zone mute		●	●		✓
Buffering messages when zone is busy			●	✓	
Standby		●	●	✓	

Table 21. LED colors on the control unit front panel

Graphic symbol	Color		miniVES Control Units
		green	POWER
		yellow	FAILURE
		red	ALARM
		yellow	Battery failure
		green	Handheld microphone active
		yellow	CPU-off function active (CPU bypass)

9.1 Normal mode

Power-on LED emits green light. In normal mode (no failure and locks) none of the LEDs in VASCU system emits yellow or red light.

9.2 Alarm mode

In this mode, all devices which are unnecessary during alarm (e.g. zone microphones, other devices which use structural network) are automatically disconnected.

An LED marked as ALARM emits red light on the fireman microphone, zone microphone and on the front panel of the Control Unit. Fire scenario is carried out. Any activities are recorded in the event log.

9.3 Failure mode

In case of damage related to one of the system modules, the system enters failure mode, and information about failure is displayed in the Control Unit and microphones. FAILURE yellow LED lights up. If the microphone has a button programmed as "confirm failure" the built in speaker also signals the failure. When failure is signaled, press the button marked as "confirm failure" to mute the alarm, the system will detect that the failure has just been accepted/confirmed by the Operator (this event is recorded in the event log). The failure LED goes out when the system damage is eliminated and "Failure delete" button is pressed.

9.4 Lock mode

VASCU can lock and unlock sound system zones. In the locked zone, no messages are played back until unlocked. When the zone is locked, the LED indicator emits yellow color on every microphone.

10. Instruction for performing tests and trials

In order to confirm that miniVES / midiVES VASCU works properly, perform a series of basic efficiency tests in accordance with the program below. Indicators and manual control elements used to perform the tests have been described in previous chapters.

10.1 Instructions for performing basic functions

10.1.1 Alarm mode

Activating alarm mode

Lift red button flap (alarm button “activate Evacuation”) and press it. However miniVES / midiVES system is not equipped with the red button protected by the flap. That means that pressing once the red button on the front panel of miniVES / midiVES activates the 5 seconds procedure (Evacuation button starts blinking RED) during which the system waits for second press of the button. Finishing this two steps procedure activates Alarm Mode. Green LED indicators will emit light in all sound system zones. The system enters alarm state and automatically activates all zones. In this state, music background and zone microphones are disconnected. It is still possible to send automatic alarm messages or via fireman microphone. The system awaits messages to given zones. The alarm state applies until the programmed as “cancel alarm” is pressed.

Cancelling alarm

During alarm state, press “Cancel Alarm” button. VASCU enters standby mode, all alarm messages are muted and background music is restored.

Sending evacuation messages

Activate alarm and select zones. A green LED next to the zone name means the zone is ready to transmit. Press “Evacuation” button. A constant red indicator next to green zone selection indicator means that evacuation message is being sent. The evacuation message will be played back in given zones in a continuous way, until the button “cancel alarm” is pressed.

Sending warning messages

Activate alarm and select zones. A green LED next to the zone name means the zone is ready to transmit. Press “Warning” button. A flashing red indicator next to green zone selection indicator means that the warning message is being sent. The warning message will be played back in given zones in a continuous way, until the button “cancel alarm” is pressed.

Sending verbal messages via microphone

Activate alarm and select zones you wish to be received in. A green LED next to the zone name means the zone is ready to transmit. Lift the microphone, press and hold “push to talk” button while speaking.. Speak slowly, loud and clearly.

Message priorities

Activate alarm and select zones. Press “Warning” button – warning message will be played back in given zones. Next, press “Evacuation” button – warning message will stop, and evacuation message will replace it because has a higher priority. Then, press “push to talk” button – all automatic messages will stop and you will be able to transmit a live message via the fireman microphone.

Transmitting automatic messages and microphone messages in various zones

Activate alarm and select one zone. Activate evacuation message or warning message playback in the given zone. Unselect this zone (green indicator goes out, red one still emits a constant light or flashes). Select another zone. To send a verbal message, press and hold “Push to talk” button and speak to the microphone.

Transmitting verbal messages when the central processing unit is faulty – CPU OFF

Set the switch on the front panel in the CPU OFF position. The CPU OFF LED will light up with a steady green light. Press “push to talk” button and speak to the microphone.

⚠ NOTE! When the switch is in the CPU OFF position, playback of the alarm messages recorded in the miniVES / midiVES memory does not work. The processor is bypassed. A direct connection between devices is created: microphone → amplifiers → loudspeakers. Microphone input is broadcasted to the entire system. Amplifiers operate at maximum amplification – be aware that this rises the SPL significantly.

10.1.2 Failure mode

A flashing yellow FAILURE LED means that one of VAS central unit elements or a loudspeaker line is damaged. On miniVES / midiVES devices and ABT-DFMS the system failure will be indicated by an acoustic signal. When the damage is signaled, press “confirm failure” button to mute the alarm sound, and the system will register that the failure was confirmed by the Operator (this event will be recorded in the event log). The failure LED goes out when the system failure is eliminated and “cancel failure” button is pressed.

A system maintenance technician or technical service must be notified of any damage immediately.

10.1.3 Controlling backup power batteries

In the miniVES / midiVES systems this process is fully automatic. It is realised by monitoring battery internal resistance.

10.2 Testing the system

Instructions for performing tests which will confirm proper efficiency of the VAS central unit.

1. Get familiar with the VAS service manual.
2. Check if VAS system stops performing any functions unrelated to warning while switching into alarm mode.
3. Check if VAS system disconnects secondary sound systems (e.g. local audio systems of room tenants, connected to VAS as sources of background music, adverts, etc.) while switching into alarm mode.
4. Check if the system is capable of sending messages within max. 3 seconds after the fire alarm system central unit sends a fire alarm signal.
5. Check if the system is capable of sending voice messages to one or several areas at a time, in accordance with established alarm schedule.
6. Check if the VAS alarm message control algorithm by FACIE is carried out in accordance with the established fire scenario for the building.
7. Check if transmitting various messages to sound system zones is properly indicated on fireman microphone.
8. Play back alarm messages recorded on a memory card in the given sound system zone in order to confirm quality and comprehensibility of the message (verify all messages recorded in the memory).
9. Check if the verbal message is actually sent to the zone defined on fireman microphone, if sound system zones are actually audible in given sound system zones (do a test for all zones).
10. Check if VAS failure information is sent to FACIE and if this connection is supervised by FACIE.
11. Check if the system detects and signals failure of loudspeaker lines properly (short-circuit, open-circuit, loudspeaker line earthing).
12. Check if the damage in the system is detected within max. 100 seconds.
13. Check if "CPU OFF" switch works properly on the fireman microphone – it is a switch responsible for bypassing the central processor unit.
14. Switch off AC power and check if the system works properly on the backup battery power supply:
 - › check if the system performs all functions related to transmitting alarm messages played back from the memory,
 - › check if it is possible to send voice messages to particular zones via the fireman microphone,
 - › check if the system has disconnected secondary sources of sound connected to VAS cabinet, which do not participate in alarming,
 - › check if the sound level while sending messages remains unchanged as a result of switching into backup power,
 - › check if the system signals AC power failure.

11. Operation instructions

11.1 Control Unit

It is possible to navigate in miniVES series L and LN devices menu via a touch-screen LCD display and nearby control buttons. The display shows a current VASCU system status. The menu allows the following:

- » monitor VASCU system status,
- » trigger loudspeaker line impedance measurement,
- » check network settings,
- » check software and firmware versions.

In case of damage in at least one of the system modules, the LCD display will show information about the fault.

The paragraph below describes operation instructions with an example of microphone panel configuration. The microphones are configured on a case-by-case basis for a specific purpose. During the first training, the person responsible for starting the system provides the microphone operation manual.

11.2 Fireman microphone

Actions described below can be executed by authorized personnel only.

Sending verbal messages to given fire zones (fireman microphone)

- » Open red "Evacuation" button flap and press it. At this moment VASCU will switch into alarm mode. However miniVES system is not equipped with the red button protected by the flap. That means that pressing once the red button on the front panel of miniVES activates the 5 seconds procedure (Evacuation button starts blinking RED) during which the system waits for second press of the button. Finishing this two steps procedure activates Alarm Mode.
- » Press a button applying to a desired zone. You can choose more than one zone. Green LEDs will light up next to selected zones.
- » Press "Push to Talk" button, hold the button and speak to the microphone. To finish transmitting, release the button.
- » Once the verbal message transmission has finished, the microphone status LED will go out.
- » To return to normal mode, press "cancel alarm" button.

Sending verbal messages to all zones

- » Open red "Evacuation" button flap and press it. VASCU will switch into alarm mode.
- » Press "all zones" button. All of the green LEDs next to buttons corresponding with zones will light up.
- » Press "Push to Talk" button. While holding the button, speak to the microphone. To finish transmitting, release the button.
- » Once the verbal message transmission is finished, the microphone status LED will go out.
- » To return to normal mode, press "cancel alarm" button.

Activating warning message in selected fire zones

- » Open red “Evacuation” button flap and press it. At this moment VASCU will switch into alarm mode. Next, choose zones you wish to send the message to.
- » Green LEDs corresponding with selected zones will light up on the microphone.
- » Press “Warning” button. To deactivate the message, press “Clear” button.
- » To return to normal mode, press “cancel alarm” button.

Activating warning message in all zones

- » Open red “Evacuation” button flap and press it or press once the red button on the front panel of miniVES and within 5 seconds press the button once again. At this moment VASCU will switch into alarm mode. Next, press the “all zones” button.
- » Green LEDs corresponding with all of the zones will light up together with the LED next to the “all zones” button on the microphone.
- » Press “warning” button. To deactivate the message, press “clear” button.
- » To return to normal mode, press “cancel alarm” button.

Activating evacuation message in selected fire zones

- » Open red “Evacuation” button flap and press it or press once the red button on the front panel of miniVES and within 5 seconds press the button once again. At this moment VASCU will switch into alarm mode.
- » Press selected zones buttons. You can choose more than one zone. Green LEDs corresponding with selected zones will light up.
- » Press “Evacuation” button. To deactivate the message, press “clear” button.
- » To return to normal mode, press “cancel alarm” button.

Activating evacuation message in all zones

- » Open red “Evacuation” button flap and press it or press once the red button on the front panel of miniVES and within 5 seconds press the button once again. At this moment VASCU will switch into alarm mode. Next, press the “all zones” button.
- » Green LEDs corresponding with all of the zones will light up together with the LED next to the “all zones” button on the microphone.
- » Press “Evacuation” button. To deactivate the message, press “clear” button.
- » To return to normal mode, press “cancel alarm” button.

Mute

- » In alarm mode it is possible to mute warning and/or evacuation messages. To do so, choose zone and press “mute” button. The messages will not be audible in this location.
- » You can choose all zones and press “mute”. Then, messages for the entire system will be muted.
- » Remember that alarm mode is active all the time – (the LED next to the ALARM symbol on the microphone chassis is on), contacts, controls and settings assigned to the alarm scenario are maintained. Muting operation is recorded in the event log.
- » Choose zone and activate warning or evacuation action to send messages again.
- » To return to normal mode, press “cancel alarm” button.

11.3 Zone microphone

Sending voice messages to a selected zones

- » Press chosen zone button. You can choose more than one zone. Green LEDs corresponding with the selected zones will light up.
- » Press “push to talk” button. Speak to the microphone while holding the button.
Note: Depending on the settings of the “push to talk” button, the button may work in the following way: first press activates the microphone, second press – deactivates.
- » The system can generate a gong (sound preceding the message). Once the gong has ended the “microphone active” LED will come back on.
Note: While sending messages from the fireman microphone, the gong is not emitted.
- » The verbal message can be sent via the microphone when the “microphone active” LED is on again. To finish transmitting messages, release the PTT button.
- » Once the verbal message has finished, LEDs corresponding with the selected zones will go out. The microphone active LED will also deactivate.

Sending verbal messages to all zones

- » Press “all zones” button.
- » Green LEDs corresponding with all of the zones will light up together with the LED next to the “all zones” button on the microphone.
- » Press “Push to Talk” button, hold it and speak to the microphone.
Note: Depending on the settings of the “Push to Talk” button, the button may work in the following way: first press activates the microphone, second press – deactivates.
- » The system can generate a gong (sound preceding the message). Once the gong has ended the “microphone active” LED will come back on.
Note: While sending messages from the fireman microphone, the gong is not emitted.
- » The verbal message can be sent via the microphone when the “microphone active” LED is on again. To finish transmitting messages, release the button.
- » Once the verbal message has finished, LEDs corresponding with the selected zones will go out. The microphone active LED will also deactivate.

Select sound source – dynamic assignment

- » Choose zones you wish to assign source of sound to. You can choose more than one zone.
- » Choose button defined as source of sound you wish to use.

12. Maintenance and service

12.1 Preparations before VAS system maintenance works

12.1.1 Initial procedures for system testing

Schedule the time of VAS system maintenance works with the building administration, inform the site administrator about activities and range of performed works, as well as about potential inconveniences during VAS inspection.

12.1.2 System testing

Inform the building administrator that VAS system is about to be tested.

Inform the building administrator and staff (e.g. guards) that it is likely that they will experience alarm and warning messages, together with inconveniences arising from system testing procedures.

Inform FACIE monitoring center possible triggering of the remote alarm or damage signal.

Considering hazardous voltage inside the operating devices, maintenance works can be performed only if the source of power has been switched off.

All repairs must be carried out by qualified technicians or engineers. To send a service request, contact your nearest Ambient System representative.

The manufacturer shall not be held responsible for any damage caused by unauthorized modification or repair.

VAS central unit safety check and electrical inspection:

- » Check if the external side of the cabinet complies with IP30 norm.
- » Check conformity notification with EN 54-16 in the front of the cabinet.
- » Check conformity with EN 54-24 for loudspeakers.
- » Check if front and rear doors are closed.
- » Check if indicators visibility of VASCU is GOOD.
- » Check and measure VASU cabinet earthing connection.
- » Check log history – VASU event log.
- » Check fire signaling central unit interface together with customer's engineer.
- » Check all of the sound correction parameters. Save and compare settings of control elements with previously recorded data. Note and investigate all deviations.
- » While evacuation message playback (use external load if the use of main speaker lines is not possible), check output level of the miniVES device. Save and compare with previous data.
- » Check automatic system defect monitoring and test by causing a fault.

Loudspeakers:

- » Measure total speaker load for each circuit, save and compare with previous results. Inspect all unexpected changes.
- » Perform subjective sound quality assesment and audibility tests in all areas with restricted access. Save sound pressure levels (SPL).

Microphone control devices:

- » Control condition and proper operation of switches/touch-fields.
- » Check microphone overall physical condition.
- » Transmit a test message, use a monitoring speaker whenever the use of main speaker lines is not possible.

System condition:

- » In case of inside the central unit chassis, it is recommended to clean it with a vacuum cleaner or use compressed air. The Central Unit must remain dry at all times, do not use water to clean it.

On-site changes:

- » Survey all areas which were subject to changes (specified by the Customer) and determine if the loudspeaker range is suitable.

Maintenance log:

- » After you finish all operations, enter maintenance results to the maintenance log.

Checklist:

- » Upon finishing maintenance, get a relevant person to sign your checklist, confirming that the system has been left in a fully operational condition. Documentation should also include your recommendations and remarks.

12.2 System maintenance

12.2.1 Daily review

All abnormalities are usually identified by the staff operating the system. VAS system operators should notify a “responsible person” of any identified problems related to the system. Any remarks should be entered into the maintenance log on a regular basis.

12.2.2 Inspection every 6 months

- ✓ Ask VAS system users about any remarks concerning system operation.
- ✓ Check maintenance log records related to inspections, repairs and controls.
- ✓ Review and read VAS system documentation.
- ✓ Review RACK system cabinet elements condition (pay attention to temperature, corrosion, humidity, cleanliness, etc.).
- ✓ Check connections, clamps and cables between particular VAS devices.
- ✓ Check for any device damage in RACK cabinet.
- ✓ Check if all lights, LEDs and indicators work properly.
- ✓ Check network and battery fuses condition.
- ✓ Check connectors and earthing connections condition.
- ✓ Check batteries in terms of corrosion and ventilation.
- ✓ Check if the battery charger works properly.

- ✓ Switch off AC power and check battery power system operation:
 - › check if the system performs all functions related to transmitting alarm messages recorded in memory,
 - › check if fireman microphone can transmit voice messages to particular zones,
 - › check if the system deactivated other PA sources connected to VAS cabinet – which do not participate directly in alarming,
 - › check if the system signals AC power failure.
- ✓ Check if information about VAS failure is sent to FACIE central unit and if this connection is monitored by FACIE central unit.
- ✓ Check if VAS alarm message control algorithm by FACIE central unit is carried out in accordance with the established fire scenario for the building.
- ✓ Check if the verbal message transmitted to the sound system zone declared on fireman microphone is actually audible in the given sound system zone (do tests for all sound system zones).
- ✓ Check if “CPU OFF” switch works properly on the fireman microphone - activating the central processing unit bypass (optional function - needs to be programmed).
- ✓ Play back alarm messages recorded on the memory card in the given sounds system zone in order to confirm the quality and comprehensibility of the message (check all messages recorded in the memory).
- ✓ Check if connections between SAP and VAS are monitored.
- ✓ Check if VAS system stops performing any functions unrelated to warning when the alarm is triggered.
- ✓ Check if VAS system disconnects all secondary systems when the alarm is triggered.
- ✓ Check if the system is capable of sending warning signals and verbal messages to one or several zones at a time, in accordance with the established fire procedure.
- ✓ Check if the system identifies and signals speaker line failure properly (short-circuit, open-circuit, earthing of loudspeaker line).
- ✓ Check if it takes the system no longer than 100 seconds to detect and signal the fault.
- ✓ Once per 6 months it is necessary to check and confirm proper performance of loudspeakers in 50% of the area of the building (100% of the area must be inspected within a year). The test must be performed by forcing loudspeaker lines to emit any signal (e.g. CD music, via microphone or previously recorded message or test sound) and by checking if all loudspeakers on the given line emit the test signal properly. While carrying out the aforesaid test, you need to check for any changes in the interior requiring relocation of loudspeakers or change of their number. Also inspect if the speaker system has been maintained properly, check for dirt, paint and mechanical damage.
- ✓ Check if transmitting messages to various zones is properly indicated on the fireman microphone.
- ✓ Check cooling fan condition.
- ✓ Disconnect the backup power batteries. Measure voltage on the charger output and on the battery terminals.
- ✓ Use software to check event log and system time clock settings.
- ✓ Use diagnostic software to check the following:
 - › microphones,
 - › power supply system,
 - › power supply manager,
 - › amplifiers,
 - › extension cards.

12.2.3 Annual inspection

All maintenance works included in the 6-month inspection apply here, yet additionally:

- ✓ Perform sound pressure level tests in randomly selected areas of the building in order to verify if there are no changes causing a decrease of parameters below the required values by EN 60849 norm.
- ✓ Check if impedance of particular loudspeaker lines is in compliant with the blueprint.
- ✓ Check alarm message scenarios sent by FAS
- ✓ Measure battery capacity – if the capacity dropped below 80% of the design capacity, batteries must be replaced.
- ✓ Safety inspection must be carried out frequently, at least every 12 months; the manufacturer recommends to take maintenance actions every 6 months.

12.2.4 Manufactures remarks

Please note that Ambient System is not responsible for results of unauthorized repairs.

Any repairs of the equipment should be carried out by the Ambient System or a service centre authorized by Ambient System.

In any unresolved issues, please contact Ambient System's trained personnel. Content contained herein is subject to change without notice. Ambient System reserves the right to change or modify the product and conditions applicable to the use of this product at any time.

13. Configuration Software

13.1 Welcome screen

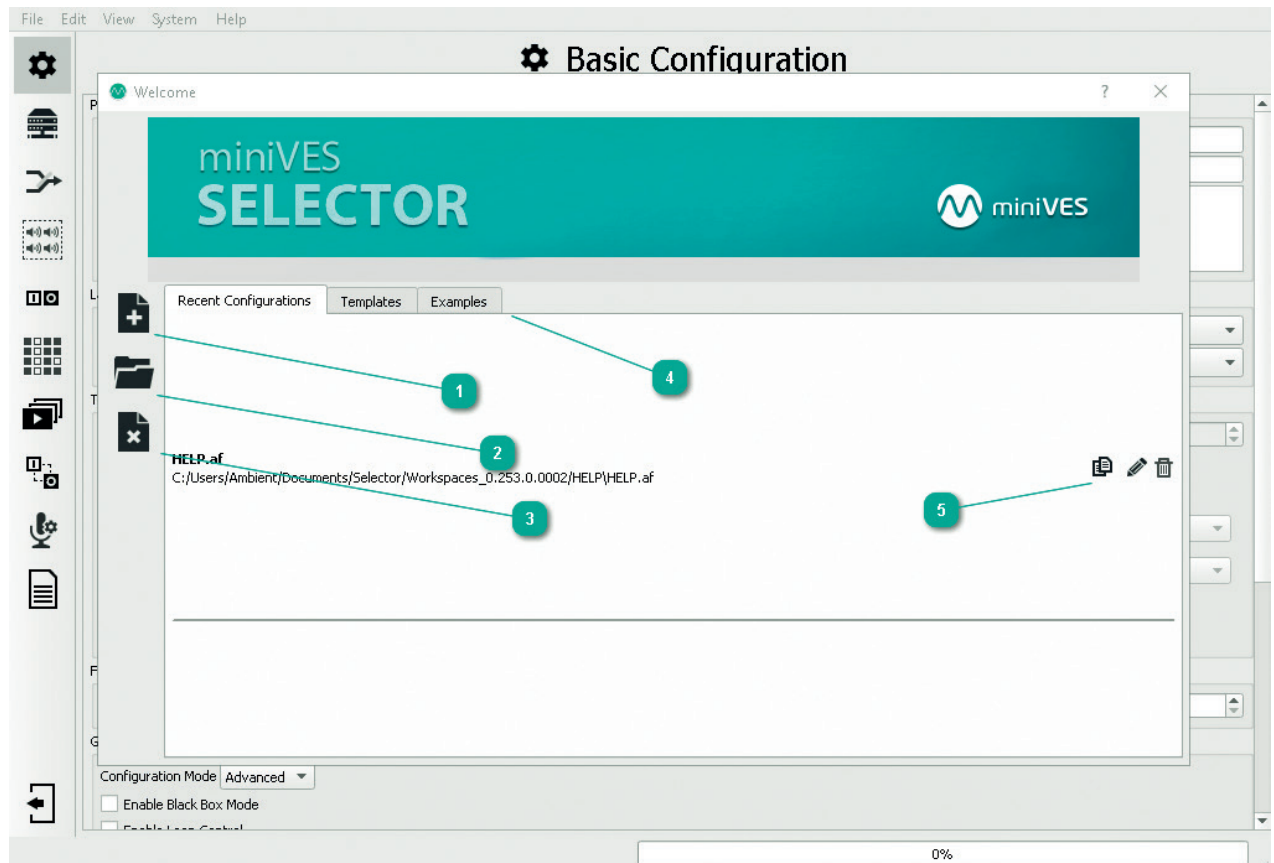

1 New configuration file localization

In order to start a project a dedicated folder for the configuration file needs to be created.

Caution: Do not select an existing folder with data, as these will be deleted!

2 Selection of configuration file from a chosen location

3 Creating a new project without saving

4 Recent and template configuration file window

5 Project cloning, changing and deleting project name

13.2 Basic Configuration

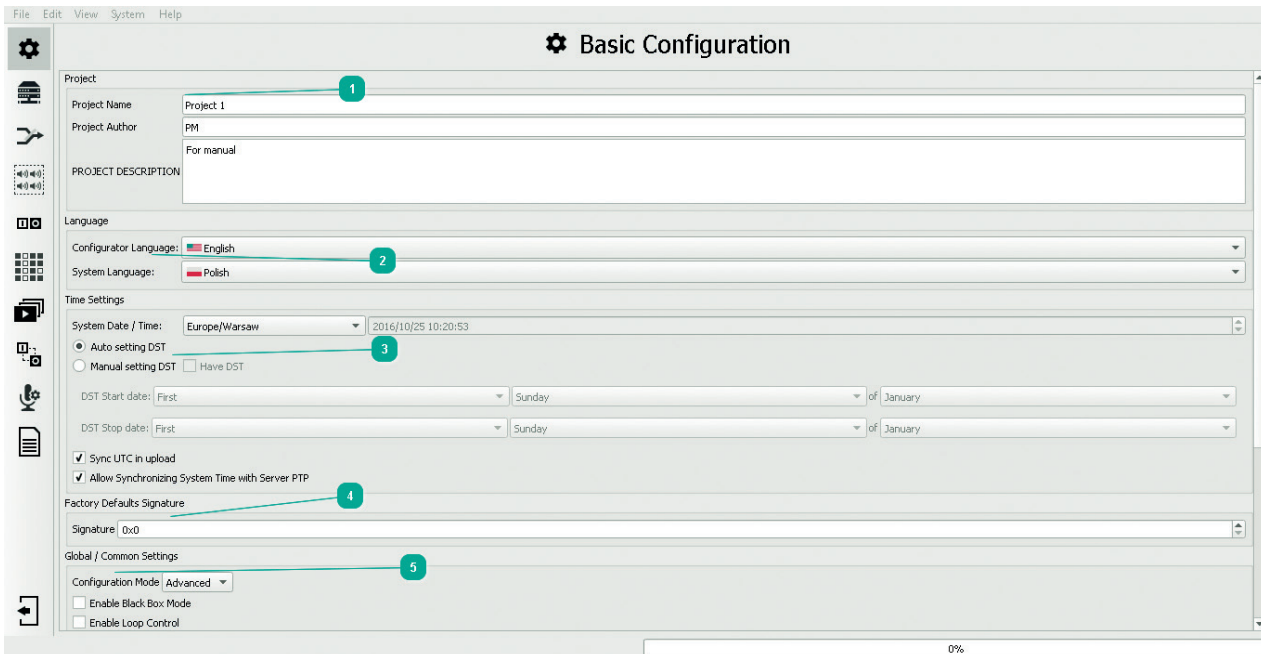

1 Project name and author window, with designer's note

The **Project** field contains basic information on configuration of the miniVES system. The name of the project and its author should be supplemented here, as well as a description which should include as many detailed data as possible, such as the place and date launched, specific features of the system, customized functions. The more detailed the project description the easier servicing and making changes in the system at a later date.

2 Language selection

The **Language** field defines the current language of the software used to configure the miniVES system – **Selector Language**. **System Language** defines the current language of all available GUI touch screens in the system.

3 System real-time clock setting

Setting the system valid time. The configurator downloads the UTC from the operating system on which the configurator is installed. In order to load time together with configuration, accept the **Sync UTC** in upload window and select the appropriate time zone in which the system will be installed. It's possible to turn daylight savings time on and off in this section. Choose **Auto setting DST** for the time to be advanced by 1 hour on the last Sunday of March at 1:00 universal time and retarded accordingly on the last Sunday of October. This applies to countries within the EU among others (UE 2000/84/EC directive). In this mode if the computer running the software is in a daylight savings zone the selector software will act accordingly and display **DST start** and **stop dates**. It's possible to manually override the transition dates by using the next option **Manual setting DST** along with **use DST** (without the latter daylight savings time will be disabled). Additionally time can be updated automatically by a PTP server connected either to the LAN port of the central unit or the LAN/WAN port.

4 Signature

Every project is assigned with a unique signature number. If the signatures between the project uploaded to the system and the one on the project in the computer software differ, the system will not allow returning to factory settings.

5 Configurator work mode

In **Global Settings** you can choose one of the configurator's modes. The **Advanced** mode, unlike the **Simple** mode, is able to create speaker zone groups, logical input/output groups, timers and scenarios. Additionally, in the **Advanced** mode, in editing logical outputs, it is possible to set individual diode operation on zone microphones. The **Enable Black Box** option – enables the fireman microphone to record audio while the system is in the alarm mode. The **Enable Loop Control** option – enabling this option turns on reporting of all errors detected in the fibre-optic loop.

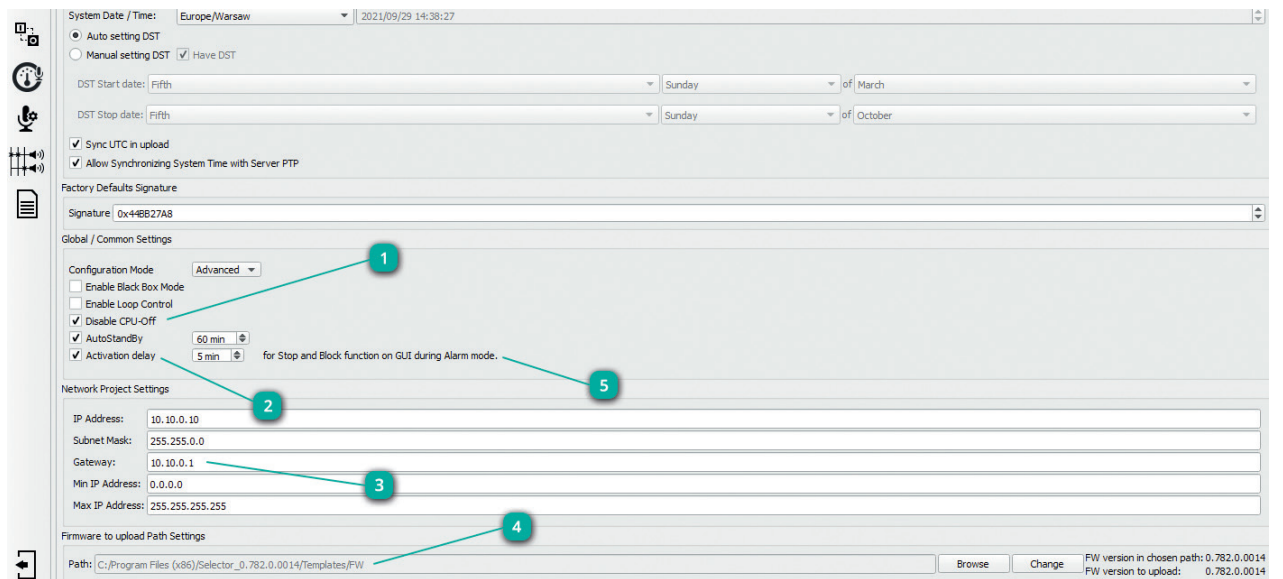

Basic Configuration editing window – continued

1 Disable CPU-OFF

This option in its default setting (on) disables the central processing unit bypass mode. In order to activate the CPU-Off function accessible from the ABT-DFMS and miniVES front panel by a dedicated switch, uncheck this box.

2 AutoStandBy

Enabling this mode in the miniVES system results in:

- › limiting current draw from the batteries when in emergency power mode;
- › limiting heat generated by the amplifier modules during standard operation mode.

The system enters **Standby** mode when no audio has been transmitted through the system for the time set in the software. The time is set in minutes in the 15 to 300 bracket. The default state of this option is active with the default time set to 60 minutes. *For more details see the appendix section.*

3 Defining IP address pool to assign system devices

This window shows the range the configurator uses to assign IP addresses to all programmable elements of the miniVES system in the internal system network. It is possible to change the settings of the assigned pool, however it is not recommended by the manufacturer. The settings should be changed prior to adding the first device to the workspace.

4 System firmware update field

Every software version has a corresponding firmware that is uploaded to the Central Units, fireman microphones and zone microphones. Every time a new configuration is uploaded to the system, the configurator software compares firmware versions. If a different firmware version than the one in the configurator is detected, it will be overwritten. It's possible to load a different (newer) firmware version than the one supplied with the software. In order to do so you must manually set the new firmware path by clicking **browse**. The new firmware path will appear in the **path** window. In order to upload the new firmware to the system, click **change** – this will display the new firmware version in the **FW version to upload** field. *For more details see the Appendix section.*

5 Stop and Block function on GUI during Alarm mode

This option allows you to set the time after which the options for stopping voice messages or blocking loudspeaker zones will return to the touch screen. The time is counted down from the moment of activation of the alarm mode in the system.

13.3 System Configuration

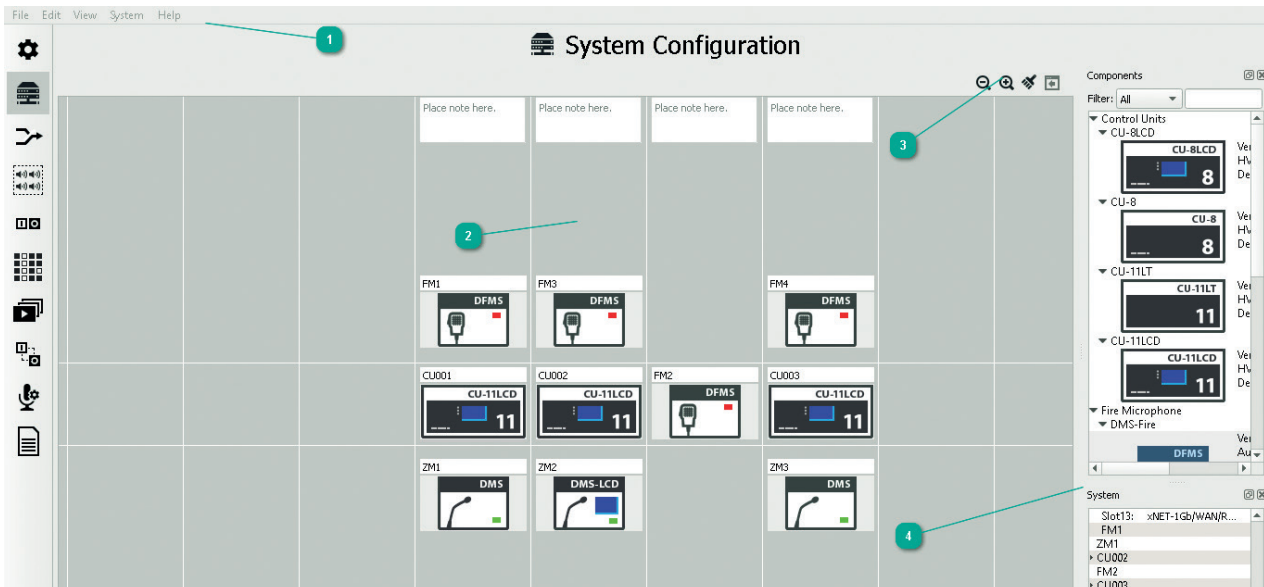

1 Main Menu bar

[File](#), [Edit](#), [System](#)

2 Workspace

The [System Configuration](#) tab is one of the most important items in the miniVES system configuration software. The main window, called [Workspace](#), represents system connections by means of vertical and horizontal lines. Placing devices along a vertical line represents a copper wire connection within a single location. The horizontal space between the two lines in the center of the workspace represents a fiber optic connection. Devices placed next to each other within this space are connected by a fiber optic link and are often separated by a greater distance. Additionally, all of the connections upwards from the central fiber connection part of the workspace are monitored – the system checks for device and link fault. The system elements placed below the central field (zone microphones) will not be monitored.

3 Components

In the top right part of the work field there is the tab with all available elements of the miniVES system – the [Components](#) tab. Upon starting a new system design, the first component you should drag and drop to the workspace (the configurator will suggest and highlight a proper field) is the central unit. In order to find it press the arrow next to [Control Units](#) in the components tab and a list of available units will drop down, next simply use the drag & drop method. The software suggests, with a grey rectangle, where a given element can be placed only if the cursor with the element being drawn is located within the work field. Repeat the procedure for [Fireman Microphones](#) and [Zone Microphones](#) tabs.

4 System

In the bottom right part of the work field there is the tab [System](#). This tab is used for detailed configuration of the devices and shows allocation of cards in individual control unit slots. Having added a control unit to the work field, the name of the unit will appear in the system tab, as well as a triangle icon meaning a drop-down list. Right-clicking on the name displays the option [Go to configuration](#). When the list drops down, a list of available slots will be displayed. Right-clicking on a slot displays additional option of [Go to configuration](#) (card detailed editing), [Add Control/Function Card](#) – adding a card to an empty slot or changing allocation of the card in the slot, [Remove Card](#) – removal of a card which was assigned to a slot before. In addition, detailed editing of elements from the work field may be triggered by double-clicking of the left mouse button on each of the devices in the work field. If the device contains more elements to be configured, as in the case of control units, then the first double click of the left mouse button results in moving to the next level of editing where we can see all defined cards in a unit. A next double click on any available element means moving to the detailed parameter card of a given element. *A detailed description of the editing window for individual elements of the miniVES system is available in the following tabs: [DFMS](#), [DMS](#), [xCtrlLine-4](#).*

13.3.1 File

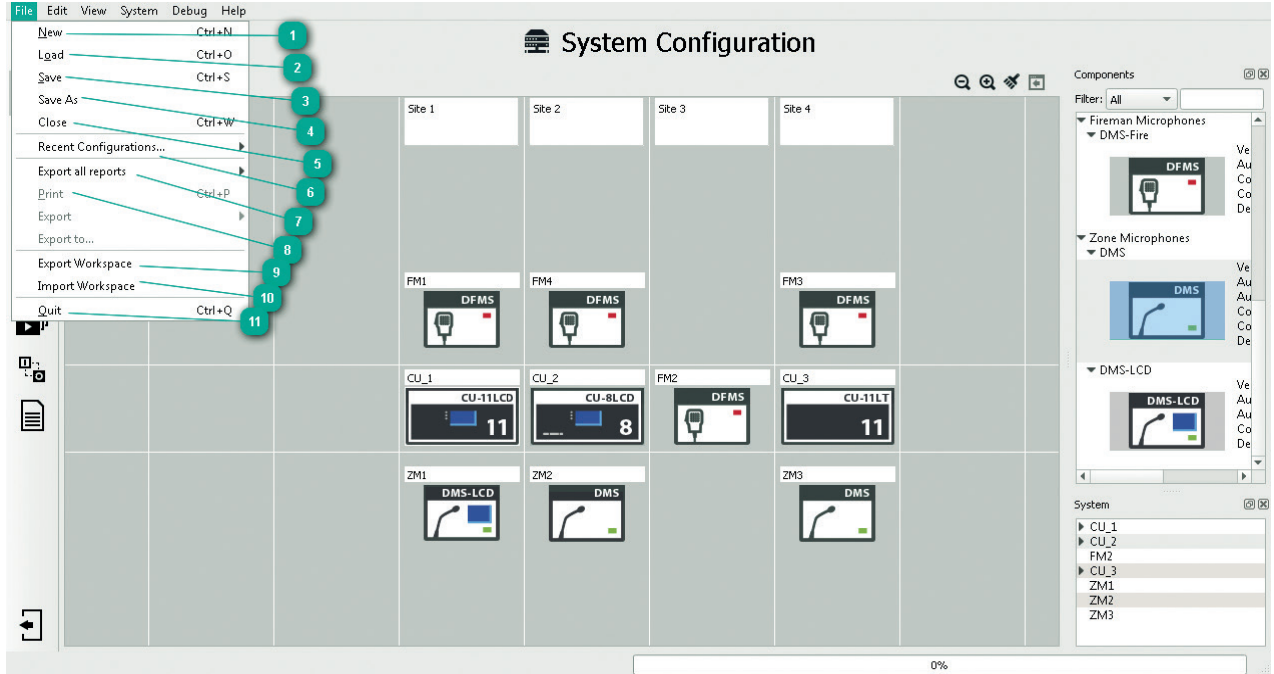

1 **New**

This option creates a new folder in which all configuration data for a given project will be saved in. In order to create a folder, click the "folder with a plus sign" icon. Creating a new or selecting an existing folder is the first thing to do to be able to go on with the configuration of the system. **Caution:** Selecting a folder with an earlier created configuration results in having the data in this folder completely deleted for the purposes of a new project.

2 **Load**

This loads a system configuration created earlier. The configuration file has the extension *.af.

3 **Save**

This saves a configuration in the created Workspace folder.

4 **Save as**

This saves a configuration in the created Workspace folder enabling a change of the *.af configuration file name.

5 **Close**

This closes the current configuration file.

6 **Recent Configurations**

The configuration software stores up to 10 recently used system configurations, you can load them using this list.

7 **Export all reports**

This generates tables from the [Reports](#) tab in one of the following formats: HTML, PDF, XML, ODF.

8 **Print**

Prints all available reports generated by the configurator.

9 **Export Workspace**

All configuration files, together with messages, are compressed into a file with the extension *.afz. This is a complete record of the configuration, unlike files with the extension *.af which do not contain messages.

10 Import Workspace

Automatic decompression of a *.afz file and loading the complete configuration of the system.
See [FAQ 3: cannot open downloaded system configuration](#).

11 Quit

Closing the miniVES system configuration software.

13.3.2 Preferences

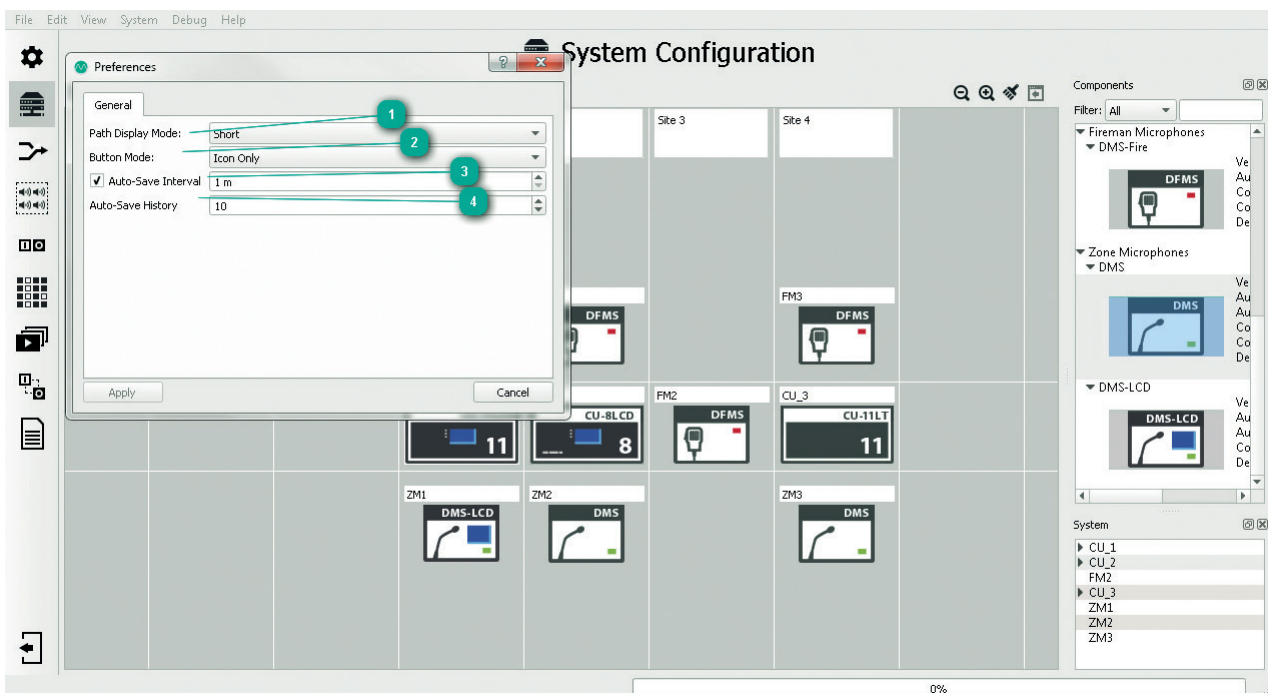

1 Path Display Mode:

The miniVES system component name display mode refers to logical input/output cards, control cards, audio inputs and audio outputs. In the [Full Path](#) mode, the name displayed consists of the name of the unit in which a given element is located, followed by a full stop and the name of the card, where the value in the brackets with # means the number of the slot in the unit in which a given card is located, and at the end, also preceded by a full stop, the name of the component is displayed. Here is an example of the full name of a control unit audio output – SM1.cCPU-Audio-4/12(#12).AO1 which means Audio Output 1 found on Integrated Audio Card 4/12 in Unit SM1.

Short Version – displays the name of a component only

2 Button Mode:

This enables personalization of the view of the configuration software. In the [Auto-Hide](#) mode, the main Icons, such as [Basic configuration](#), [System configuration](#), [Priority Manager](#), [Group Zone Configuration](#), [Matrix](#), [Scenario](#) and [Event Configuration](#) have no subtitles and moving the mouse cursor over an icon results in all icon names being displayed:

Text and Icon – icons and names are always visible

Icon only – only icons are always visible

Text only – only names are visible

3 Auto-Save Interval

This option, when activated, results in having the current configuration saved into the configuration file at predefined intervals expressed in minutes.

4 Auto-Save History

In this section you declare the number of autosave configurations you wish to be stored in the software. It is closely linked to the autosave interval, if the interval is set to 1 minute and the value of the autosave readout is 10, then the configurator will allow to load the maximum of 10 minutes back. Of course, both the save interval and the number of files to read may assume a value from 1 to 99.

13.3.3 System

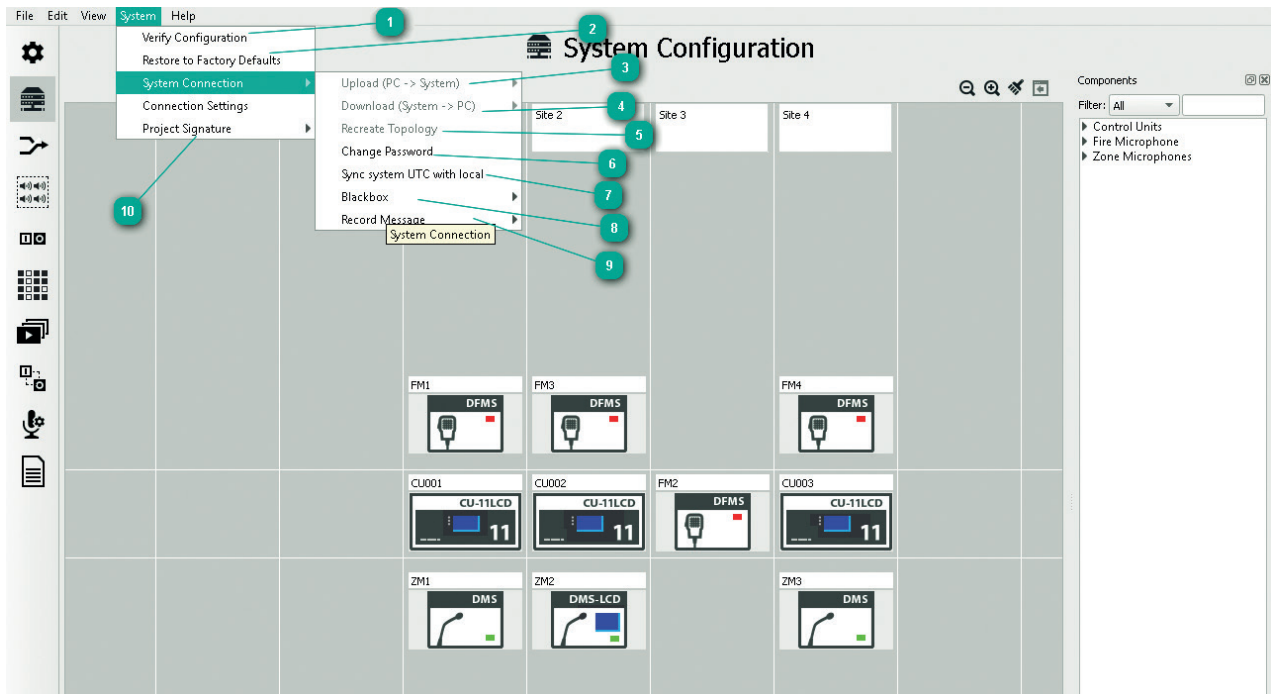

1 Verify Configuration

The configurator checks created configuration for its integrity. It classifies verified elements into 3 groups – **Errors**, **Warnings** and **Info**. If the software detects configuration errors, it will not allow it to be loaded into the system. By selecting [Show details](#), we gain access into the details of the problems which have occurred.

2 Restore to factory defaults

This function completely erases configuration files, logs and audio files from all of the devices connected to the miniVES system. All of the memory cards will be formatted and the devices will be assigned with IP addresses from the 192.18.x.x pool. The packets responsible for the [factory settings](#) commands are UDP and are received regardless of the set internal IP addresses in the system. If the System has executed the [restore to factory defaults](#) command, the project signature has also been changed, in order to update it in the configurator software you must download the system configuration. You can also select the [recreate topology](#) option, enter an empty configuration into the system and then restore the system to factory defaults.

3 [System Connection / Upload \(PC -> System\)](#)

This allows to send a configuration, created on a PC running the configurator software to the miniVES system connected to that PC. Prior to sending the configuration to the system, the software verifies the configuration file. [Upload full configuration](#) – sends the entire configuration from the PC to the system, including audio files in the PCM format. Loading of a full configuration must be executed for the first time an empty system is being programmed, every successive configuration change which does not require changes in audio files may be loaded into the system via [Upload configuration without audio](#) which makes programming of the system much faster.

4 [System Connection / Download \(System -> PC\)](#)

This allows to download the current full system configuration or the configuration prior to the current one from system into a PC.

5 [System Connection / Recreate Topology](#)

This function reads the system architecture. The system is able to identify cards located on a particular slot of the control unit, it detects all zone and fireman microphones connected and the method and place of connection of the units and microphones (optical fibre, cat5). **Caution:** the only element which is not detected by the system recreating topology are microphone extensions.

6 [System Connection / Change password](#)

Allows to change the previously set password needed to upload the configuration to the system. The change is authorized either by entering the previous password or by generating a token. The token is created by Ambient System after received a five digit code generated by the Control Unit GUI (applies only to units equipped with LCD screens).

7 [System connection / Sync system UTC with local](#)

This option synchronizes the system's internal clock with the time on the computer running the configurator software.

8 [System Connection / Blackbox](#)

The [Blackbox](#) function records audio from all connected DFMS fireman microphones while the alarm mode is active. [Download blackbox buffer](#) retrieves the data stored in the microphones. [Clear blackbox buffer](#) - erases all the messages recorded during alarm mode.

9 [System Connection / Record message](#)

If this function has been enabled in the system you can download the messages recorded by DFMS, DMS or DMS-LCD microphones by clicking [Download record message buffer](#). [Clear record message buffer](#) deletes all the messages.

10 [Project signature](#)

The [project signature](#) acts as a key which is needed for remote server access. If the system is set up correctly and the configuration has been sent to all the devices, the project signature should be sent to the remote access server administrator.

NOTE: After changing the signature the server with remote access will no longer be able to connect. The access rights are assigned to the administrator (key), but also to a specific system with given signature.

13.3.4 System Connection Settings

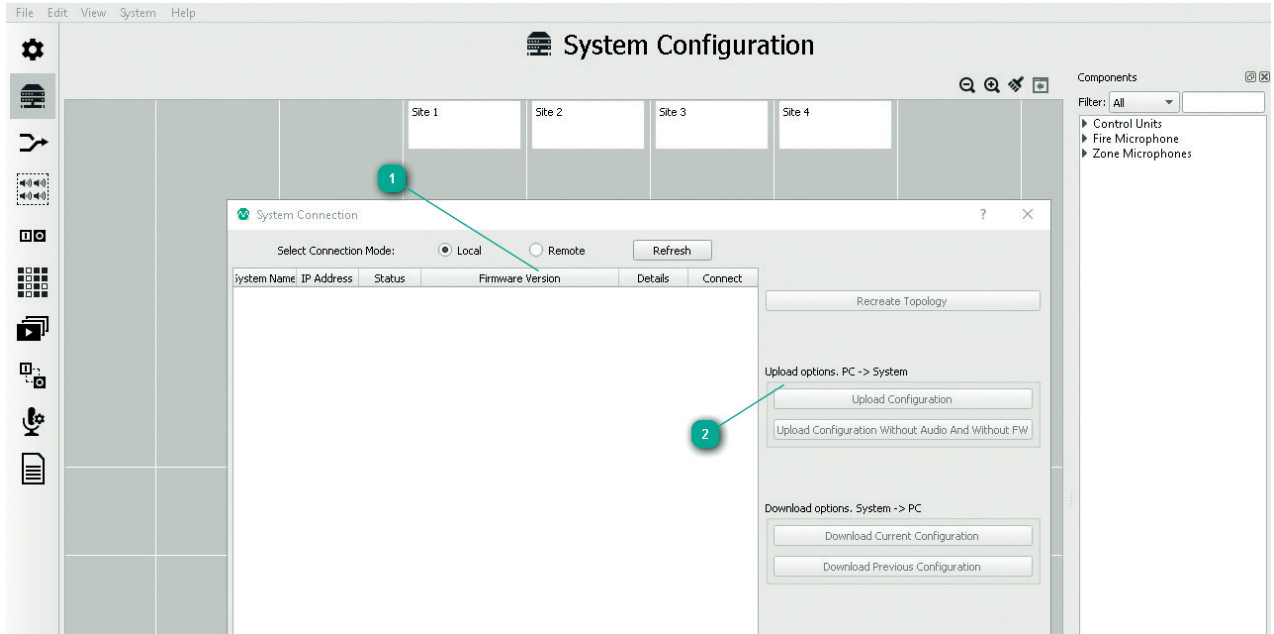

1 Connection Settings

This window allows the system to connect with a PC. If the DHCP server is configured correctly, then in the **Connection Settings** a server name identical to the one of the unit the PC is connected to should appear. In the case of connecting to a clean unconfigured system, the server will be named **NewSystem**. It must be remembered that automatic IP address acquisition should be set on the network interface controller of the computer connected to the miniVES system. In case a DHCP server is missing, select from the settings the option of IP address automatic acquisition, the miniVES system will detect the lack of a DHCP server and, using the AutoIP protocol, will assign an address from the special address pool 169.254.x.x to the communications card of the control unit and the computer network interface controller connected to it. If a connected server does not appear in the window – see *FAQ 1 Server not visible in the connection window*. In the case of an external active DHCP server in the network (e.g. a switch) the IP addresses are assigned to both the PC and the miniVES system.

The **Remote** option – allows the configurator to connect to the MULTIVES/ miniVES global server. All units worldwide with an internet connection and the owners consent to do so connect to the global server. Through the MULTIVES/miniVES global server, the Ambient System support team may upgrade the software, create configurations and detect system errors.

This window also displays progress while loading a new configuration into the system. Having loaded the configuration, the **Connection** window will have a message displayed of configuration loading completion and two identical configuration versions existing on the PC and the miniVES system.

2 System Connection options

Recreate Topology – this function reads the system architecture. The system is able to identify cards located in a particular slot of the control unit, it detects all zone and fireman microphones connected and the method and place of connection of the units and microphones (optical fibre, cat5). **Caution:** the only element which is not detected by the system recreating topology are microphone extensions.

Upload options. PC -> System – this allows to send a configuration, created on a PC running the configurator software to the miniVES system connected to that PC. Prior to sending the configuration to the system, the software verifies the configuration file. **Upload full configuration** – sends the entire configuration from the PC to the system, including audio files in the PCM format. Loading of a full configuration must be executed the first time an empty system is being programmed, every successive configuration change which does not require changes in audio files may be loaded into the system via **Upload configuration without audio** which makes programming of the system much faster.

Download options. System -> PC – This allows to download the current full system configuration or the configuration previous the current one from the central unit.

13.3.5 Workspace

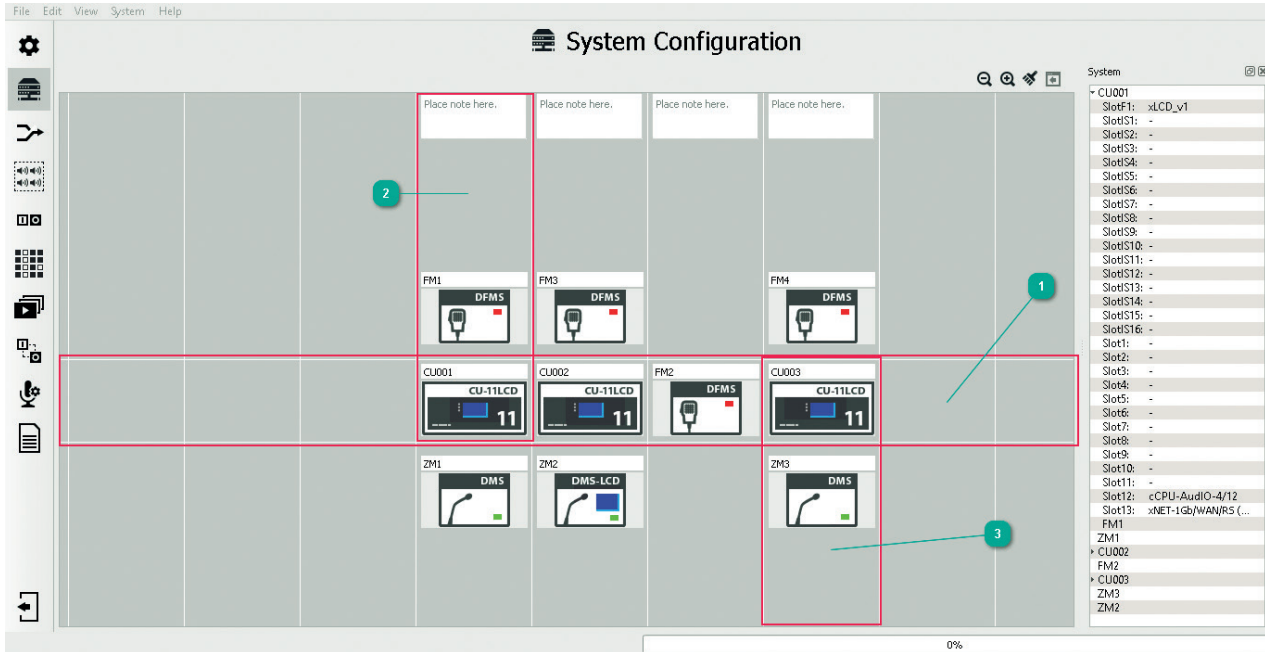

1 Fibre-optic link horizontal line

System elements arranged along this line are connected to each other by means of an optical fibre. The fibre-optic link makes the main communication loop of the system. The types of the connectors are specified in the technical documentation.

2 Vertical line of system component connection by means of Cat5 UTP cable – monitored

System elements are arranged along a vertical line. Within one column, they connected to each other by means of a Cat5 UTP cable. This is a local connection, monitored within one location, intended only to connect control units and fireman microphones.

3 Vertical line of system component connection by means of Cat5 UTP cable – unmonitored

System elements are arranged along a vertical line. Within one column, they are connected to each other by means of a Cat5 UTP cable. This is a local connection, unmonitored, intended only for zone microphones.

13.3.6 Central Unit Configuration

The screenshot shows the 'System Configuration' window for a device named 'CU002.xNET_MINI(#-13)'. It features fields for Name, Serial Number, and MAC Address. Below are two tables: 'Audio Inputs' and 'Audio Outputs'. The 'Audio Inputs' table has columns for Name, Type, Attenuation, Play after record, Max Time, Max Delay, DSP, and Level Meter. The 'Audio Outputs' table has columns for Name, Connection, Pilot Active, Feedback Destroyer, Volume, Delay, Limiter Threshold, DSP, Limiter Status, and Level Meter. Numbered callouts (1-10) point to specific elements: 1 (Device name), 2 (On-Line button), 3 (Audio Input Name), 4 (Play after record checkbox), 5 (DSP Configure button), 6 (Audio Input Name), 7 (Audio Input Name), 8 (Pilot Active checkbox), 9 (Feedback Destroyer checkbox), and 10 (Limiter Threshold).

1 Device name

2 On-Line button

The online mode offers the user the possibility to view the audio level meter in real time and to adjust the mic volume level. After uploading the configuration into the system you can enter the on-line mode by clicking the icon – it will then change its color to green indicating active on-line mode.

3 Audio Inputs

The Audio Inputs field contains all available audio inputs on the miniVES central unit. Item 1 is the built in microphone used only in the **Alarm** mode – as the standard setting, the input at Item 1 always has the highest priority of 0 (see the [Priority Manager](#) tab – the built in microphone in alarm mode may have priorities assigned from the range 0-99). Item 2 is the same physical microphone as in Item No 1, however with a **General** type priority (200-299). The Item 2 microphone is used to transmit ordinary messages in the miniVES system, e.g. Public Address. Double-clicking the name of the audio input enables to change the generic name assigned by the configurator. Item No 3 is the Line in input located on the charger module of the miniVES central unit. This input has a general type priority assigned by default, a double-click on the name field enables to change the generic name.

4 Audio Inputs / Play after record

Activating the [Play after record](#) option allows recording up to 40 s of a message being transmitted by the built in microphone and playing it back immediately after releasing the PTT button.

Max time – sets the length of recorded message

Max delay – sets the longest time the system will wait for the intended transmission zone to be freed. After the set time the message will be played back from the buffer. If the operator chooses to transmit to more than one zone, the system will play the message in all the available / free zones after the set delay time has passed and erase the message from the buffer.

5 Audio Inputs / DSP Configure

The Line in input has a 3 band parametric equalizer which can be freely configurable in two ways: by uploading the configuration to the system with the center frequency, filter quality and gain settings or by changing the parameters of the filters in on-line mode.

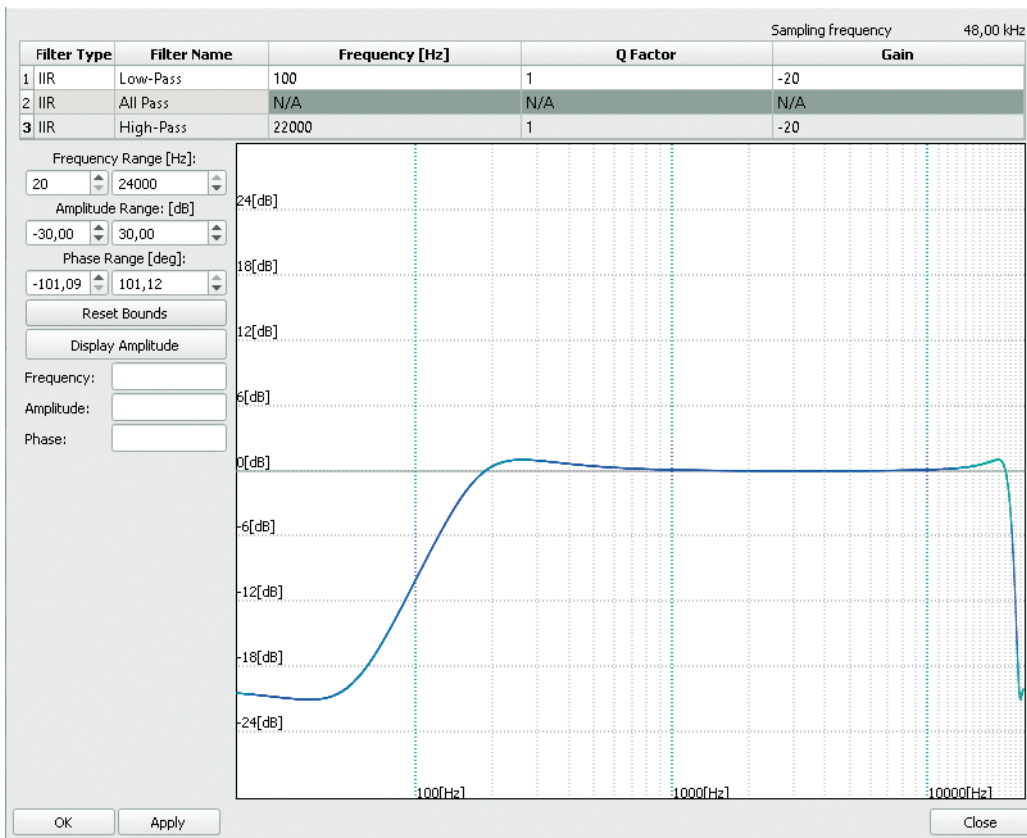

6 Audio Outputs / Name

The miniVES has 3 independent audio outputs. Double-clicking the name of the audio output enables to change the generic name assigned by the configurator.

7 Audio Outputs / Connection

This tab displays the internal connection of a given audio output. Unlike the MULTIVES system these connections are pre-defined in the miniVES. The first one being wired to the internal speaker, the second one is connected to the internal 100 V bus through the amplifier modules providing 100 V signal to the line control cards and the third one is a line output located on the miniVES charger module. The line output is not monitored by the system. The unit treats the output line as a zone in the system (eg. signal to an independent PA system) to which it can transmit the message.

8 Audio Outputs / Pilot active

Selected [Active Pilot](#) option activates the control of the connection between audio output (DSP) and amplifier module. The pilot signal is also used by the line control cards to supervise the speaker lines.

9 Audio Outputs / Feedback Destroyer

Activating [Feedback Destroyer](#) means that in places where the speakers are located in close proximity to the system microphone, the effect of acoustic feedback will be significantly limited.

10 Audio Outputs / Signal Processing

The window allows to change parameters like delay, volume level, limiter threshold and EQ. Setting the parameters is possible in two ways:

1. by changing the values in a particular window [Volume / Delay](#) and uploading the configuration to the system;
2. by changing the parameters in the [Volume / Delay](#) section in on-line mode.

Outputs 2 and 3 of the miniVES Central Unit have an 8 band parametric equalizer which can be freely configurable in two ways:

1. by changing the center frequency, filter quality and gain and uploading the configuration to the system;
2. by changing the parameters of the filters in on-line mode.

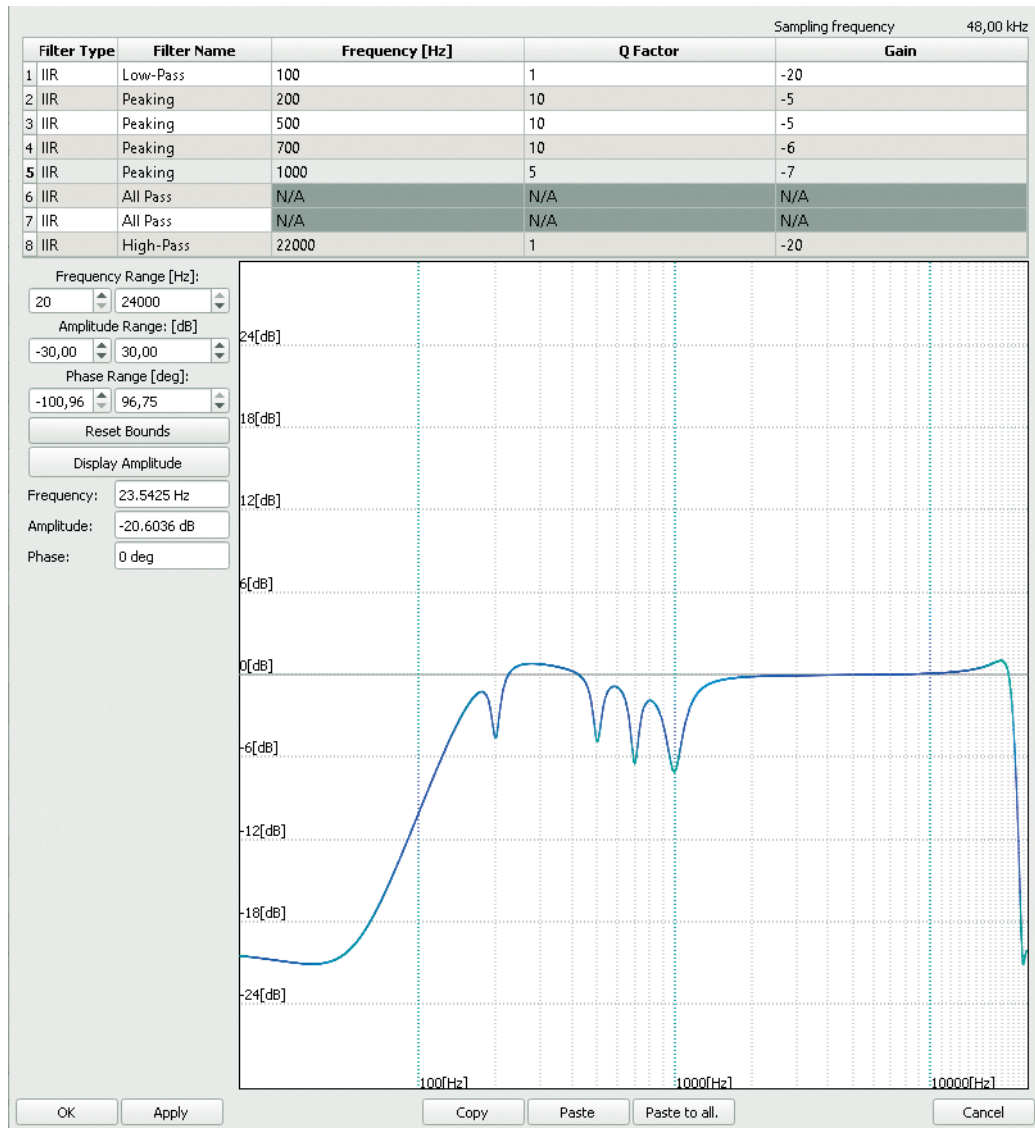

[Paste to all](#) function allows to copy EQ settings to all outputs available in the control unit. To do so select [Copy](#) to save the settings of the filters and then select [Paste to all](#) to propagate all filters settings to all outputs.

Setting the level of threshold below 0 dB activates the audio limiter. Signal level exceeding threshold is indicated by the red color in the [Limiter](#) status. Green indicates that the output is below the threshold. In practice activation of audio limiter means that above a threshold, output signal is not increasing, regardless of what value the input signal reaches. The [Limiter](#) allows to protect the system amplifiers from clipping the signal peaks and sharp reduction in high-level transients without affecting the essential content sound material.

[Signal Level Meter](#) is only active in on-line mode. The maximum level shown on the indicator corresponds to the voltage of 1 V RMS output codec.

Battery power supply

Online Params	Values	Ref. Params	Values	ACCU Capacity
Battery Voltage.	N/A	Ref. Current.	0	0
Charge Current.	N/A	Ref. Resistance.	0	
Battery Resistance.	N/A			
Battery Temperature.	N/A			
System Current.	N/A			

11 Online Parameters

This tab is updated in the online mode, giving the user a live preview of the charger unit parameters. This enables the user to control the state of the battery array.

- › **Battery Voltage** – displays the existent voltage in the battery circuit.
- › **Charge current** – displays the current in the battery circuit, this value is compared with a reference value calculated from the battery capacity.
- › **Battery Resistance** – displays the current battery resistance, , this value is compared with a reference value calculated from the battery capacity.
- › **Battery Temperature** – displays the data from the battery temp. sensor connected to the 3.5 mm jack on the charger unit.
- › **System Current** – splays a total momentary current draw from the main PSU.

12 Accu Capacity

In this field, the capacity of the installed batteries is selected. Choose the capacity of a single battery included in your array. For example, for a 4 × 5 Ah array – choose 5. From this, the system will calculate the reference charge current and battery resistance values.

Logical Inputs				
1	Emergency		Events	
2	Key2		Events	
3	Key3		Events	
4	Key4		Events	
Name		Mode	Default	Events
1	CU002.xNET_MINI(#-13)LI00008(#5)	Contact	NO	Events
2	CU002.xNET_MINI(#-13)LI00009(#6)	Contact	NO	Events
3	CU002.xNET_MINI(#-13)LI00010(#7)	Contact	NO	Events
4	CU002.xNET_MINI(#-13)LI00011(#8)	Contact	NO	Events
5	CU002.xNET_MINI(#-13)LI00012(#9)	Contact	NO	Events
Name		Mode	Default	Events
1	CU002.xNET_MINI(#-13)LI00013(#10)	Contact	NO	Events
2	CU002.xNET_MINI(#-13)LI00014(#11)	Contact	NO	Events
Logical Outputs				
Name		Relay Type	Mode	
1	CU002.xNET_MINI(#-13)LO00030(#12)	NC	Normal	
2	CU002.xNET_MINI(#-13)LO00031(#13)	NO	Normal	
3	CU002.xNET_MINI(#-13)LO00032(#14)	NO	Normal	

13 Logical Inputs / buttons

The **Logical Inputs** tab contains all available buttons as well as logical inputs on the miniVES central unit. The first four items in this section are buttons located on the front panel of the miniVES. The next seven inputs are located on the charger module. Lastly, there are two additional inputs located on the xNET_mini communications card in the xxxxN series devices. A double click on the name of a button / logical input enables to change the generic name assigned by the configurator.

14 Logical Inputs / Events

The **Events** buttons transfers the programmer directly to the **EventConfiguration** tab. This enables to assign any function or event group to a selected button. A right-click on the name of a button / logical input in the **EventConfiguration** tab, as well as selection of **Go to definition**, enables to return quickly to the editing menu of the **Central Unit**.

15 Logical Inputs / Mode

The logical input editing window enables activation of the input monitoring function – **Mode Contact / Monitor**. In case the **Monitor** option is selected, it is necessary to install two 4.7 kΩ parametrizing resistors at the end of the line. In the window **Default**, we select the input status for inactivity for the **NC** option the system expects a closed circuit, opening the circuit results in activation of the function assigned in **EventCongifuration**. For **NO** the situation is reverse: the system expects an open circuit on the input, closing results in activation of the assigned function.

16 Logical Output / Name

The **Logical Outputs** tab contains all available logical (relay) outputs on the miniVES central unit. A double click on the name of a logical output enables to change the generic name assigned by the configurator. Assigning a function to a chosen relay is possible in the **EventConfiguration** – select an input event, assign a general function and click **Add control outputs** action (the circle in a square icon ).

17 Logical Output / Settings

The relay type window informs about the physical type of the relay installed. **NC** – normally closed, in case of a power cut, the relay will be closed, **NO** – normally open, in case of a power cut, the relay will open. The **Mode** window enables to reverse the relay logic, opposite to its behaviour in case of a power cut. The **Inverse** causes, e.g., that the relay **NC / Inverse** – in the original status it is a NO relay, and activation of the function to which it is assigned will change the status of the relay into the opposite one, i.e. NC. For **NC / Normal** in the original status (not triggered by any function) the relay is closed, activation of the function, as assigned to this output, causes that the relay status changes into the opposite one, i.e. open. The values from the windows **Relay Type** and **Mode** are also duplicated in the information window below **Scenario State** and in the **EventConfiguration** tab the function **General – Logical Outputs**, also in the information window below **State**.



18 Memory size

In this field, the capacity of the microSD card on the xNET_mini card is displayed after downloading the system topology.

It is not recommended to modify this value.

19 Microphone configuration

The dedicated section for PTT button, placed on handheld built-in microphone. Apart from the [PTT](#) mode – Push to talk in the [Mode](#) option, there is a possibility to select [LOCK](#), i.e. having pressed the PTT button, the microphone is active for the time defined in the [Lock Timeout](#) window. The maximum microphone activation time is 60 seconds. The [Start Gong](#) option – this activates the gong having pressed the PTT button; [End Gong](#) will be activated after the PTT button is released.

20 Message window

This field contains the names and properties of messages uploaded to the system.

21 Adding messages

By selecting the [+](#) icon we add a sound file. The configuration software accepts formats audio MP3 and wav and converts them to the PCM 48 kHz 16 bit format which is used by the miniVES system. In addition, we can attribute an individual name to the added audio file ([Message Name](#)), which will enable its identification within the system. The [Global](#) option – means that a message will be saved on the memory cards of all available units in the system. The [Local Copy](#) option – clicking [Copy](#) will result in saving the original audio file (prior to its conversion into PCM) in the Workspace folder. [Replace File](#) – this is used to replace a selected audio file with another one. The [✖](#) icon deletes all messages held on the list. The [▶](#) icon is used to hear audio files on a computer on which the configuration software is installed, before these are loaded into the system.

13.3.7 DFMS

The screenshot shows the DFMS configuration interface with the following sections and callouts:

- 1** Name: FM3
- 2** Audio Inputs table
- 3** Logical Inputs table (Key2)
- 4** Events column in Logical Inputs table
- 5** Logical Inputs table (LI007/#1)
- 6** Logical Outputs table (LO00147/#20)
- 7** Logical Outputs table (LO00148/#21)
- 8** Logical Inputs table (Emergency)
- 9** Mac Address field

Name	Type	Volume	Play after record	Max Time	Max Delay	Level Meter
1 AI0037(#1)	Mic	0.00 dB	<input type="checkbox"/>			
2 AI0038(#2)	Mic		<input type="checkbox"/>	0 s	60 s	

Name	Mode	Default	Events
1 LI007(#1)	Contact	NO	Events
2 LI008(#2)	Contact	NO	Events

Name	Relay Type	Mode
1 LO00147(#20)	NC	Normal
2 LO00148(#21)	NO	Normal

Memory settings
 Memory size: 8192 MB

1 Name

The name field enables assignment of an individual name to the fireman microphone, other than the generic name assigned by the configurator.

2 Audio Inputs

The **Audio Inputs** field contains all available audio inputs on the DFMS microphone. Item 1 is the microphone used only in the **Alarm** mode – as the standard setting, the input at Item 1 always has the highest priority of 0 (see the **Priority Manager** tab – the fireman microphone may have priorities assigned from the range 0-99). Item 2 is the same physical microphone as in Item No 1, however with a General-type priority (200-299). The Item 2 microphone is used to transmit ordinary messages in the miniVES system, e.g. Public Address. Double-clicking the name of the audio input enables to change the generic name assigned by the configurator.

3 Logical Inputs

The **Logical Inputs** tab contains all available buttons as well as logical inputs on the fireman microphone. A double click on the name of a button / logical input enables to change the generic name assigned by the configurator.

4 Events

The **Events** buttons transfers the programmer directly to the **EventConfiguration** tab. This enables to assign any function or event group to a selected button. A right-click on the name of a button / logical input in the **EventConfiguration** tab, as well as selection of **Go to definition**, enables to return quickly to the editing menu of the fireman microphone.

5 Mode / Default

The logical input editing window enables activation of the input monitoring function – **Mode Contact / Monitor**. In case the **Monitor** option is selected, it is necessary to install two parametrizing resistors at the end of the line, of 4.7 kΩ.

In the window **Default**, we select the input status for inactivity for the **NC** option the system anticipates a closed circuit on the input, opening results in activation of the function assigned in **EventConfiguration**. For **NO** the situation is reverse: the system anticipates an open circuit on the input, closing results in activation of the assigned function.

6 Logical Outputs

The **Logical Outputs** tab contains all available logical (relay) outputs on the fireman microphone. A double click on the name of a logical output enables to change the generic name assigned by the configurator. Assigning a function to a chosen relay is possible in the **EventConfiguration** – select an input event, assign a general function and click **Add control outputs** action (the circle in a square icon ).

7 Relay Type / Mode

Relay type is a window to inform of the physical type of the relay installed. **NC** – normally closed, in case of a power cut, the relay will be closed, **NO** – normally open, in case of a power cut, the relay will be open.

The **Mode** window enables to reverse the relay logic, opposite to its behaviour in case of a power cut. The **Inverse** causes, e.g., that the relay **NC / Inverse**– in the original status it is a NO relay, and activation of the function to which it is assigned will change the status of the relay into the opposite one, i.e. NC. For **NC / Normal** in the original status (not triggered by any function) the relay is closed, activation of the function, as assigned to this output, causes that the relay status changes into the opposite one, i.e. open. The values from the windows **Relay Type** and **Mode** are also duplicated in the information window below **Scenario State** and in the **EventConfiguration** tab the function **General – Logical Outputs**, also in the information window below **State**.

8 Audio input options

Activating the **play after record** option allows recording up to 40 s of a message being transmitted by the ABT-DFMS and playing it back immediately after releasing the PTT button.



	Name	Type	Volume	Play after record	Max Time	Max Delay	Level Meter
1	A10037(#1)	Mic	0.00 dB				
2	A10038(#2)	Mic		<input type="checkbox"/>	40 s	60 s	

Max time – sets the length of recorded message.

Max delay – sets the longest time the system will wait for the intended transmission zone to be freed. After the set time the message will be played back from the buffer. If the operator chooses to transmit to more than one zone, the system will play the message in all the available / free zones after the set delay time has passed and erase the message from the buffer.

	Name	Type	Volume	Play after record	Max Time	Max Delay	Level Meter
1	A10037(#1)	Mic	0.00 dB				
2	A10038(#2)	Mic		<input type="checkbox"/>	40 s	60 s	

9 On-line mode

The online mode offers the user the possibility to view the audio level meter in real time and to adjust the mic volume level. After uploading the configuration into the system, you can enter the on-line mode by clicking the icon  – it will then change it's color to green indicating active on-line mode .

DFMS editing window – continued

1 Extension Configuration

In this window the user declares the number of connected extensions. The maximum of 5 20-button extensions can be connected to the microphone. Respectively to the selected number of extensions, the configuration window will extend to include the field for additional button name editing and ability to assign a function using the [Events](#) button. The extended editing field is shown below:

Ext1	Ext2	Ext3	Ext4	Ext5				
5	Key5				Events	15	Key15	Events
6	Key6				Events	16	Key16	Events
7	Key7				Events	17	Key17	Events
8	Key8				Events	18	Key18	Events
9	Key9				Events	19	Key19	Events
10	Key10				Events	20	Key20	Events
11	Key11				Events	21	Key21	Events
12	Key12				Events	22	Key22	Events
13	Key13				Events	23	Key23	Events
14	Key14				Events	24	Key24	Events

2 Fireman Microphone Configuration

The fireman microphone [PTT button](#) function window. Apart from the [PTT](#) – Push to talk mode in the [Mode](#) option, there is a possibility to select [LOCK](#), i.e. having pressed the PTT button, the microphone is active for the time defined in the [Lock Timeout](#) window. The maximum microphone activation time is 60 seconds.

The [Start Gong](#) option – this enables the gong having pressed the PTT button; [End Gong](#) will be activated after the PTT button is released.

3 Network Settings

This is the address which will be assigned to a physical device having loaded a configuration into the system. Changing IP addresses assigned by the configurator is not recommended.

4 RS485 Settings

The RS485 port allows the system to communicate with external devices. However, this requires selecting the appropriate protocol from the list.

13.3.8 DMS

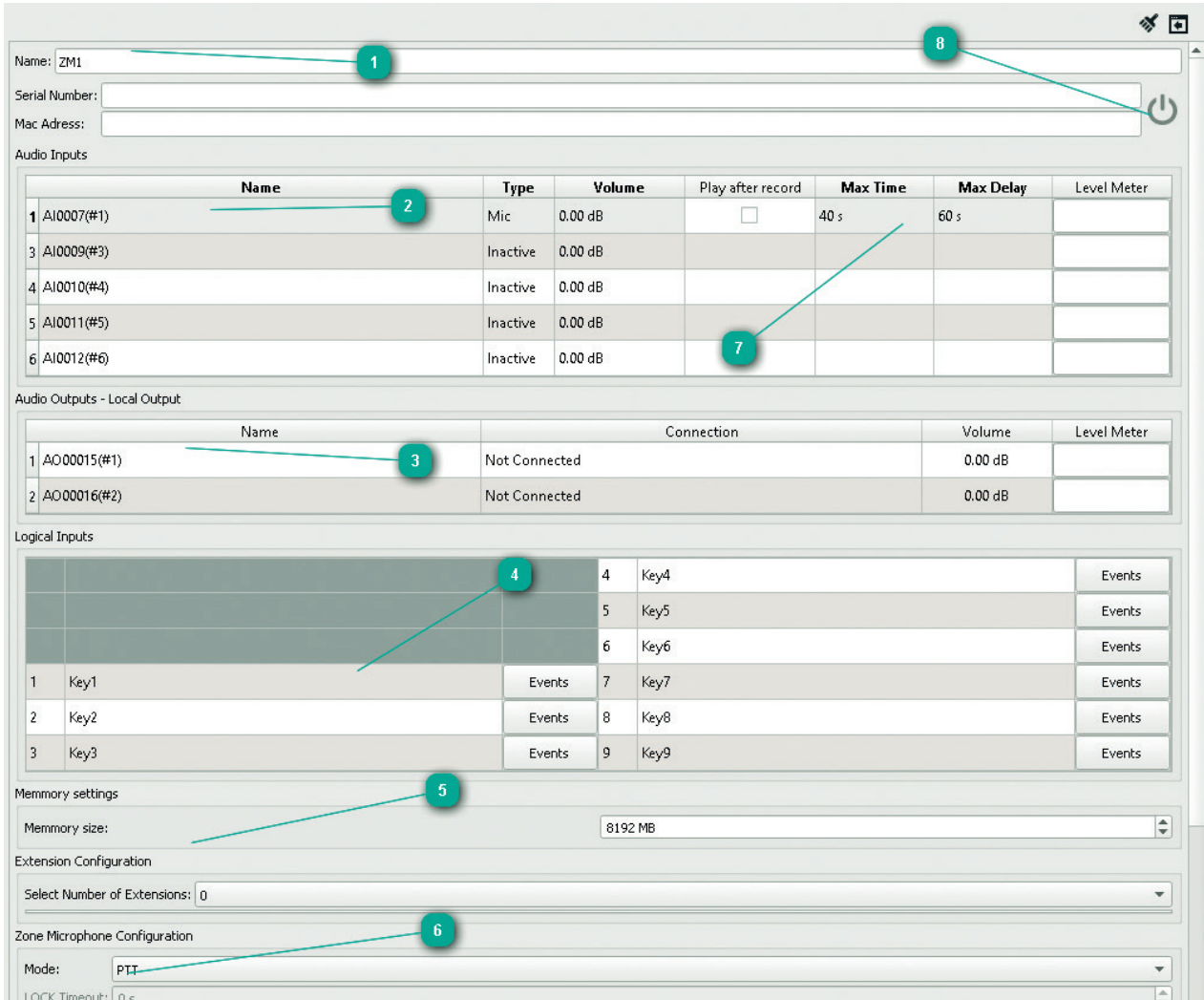

The screenshot shows the DMS configuration interface with the following sections and callouts:

- 1**: Name field (ZM1)
- 2**: Name field in the Audio Inputs table (AI0007(#1))
- 3**: Name field in the Audio Outputs - Local Output table (AO00015(#1))
- 4**: Key field in the Logical Inputs table (Key4)
- 5**: Memory size field (8192 MB)
- 6**: Mode field in the Zone Microphone Configuration (PTT)
- 7**: Play after record checkbox in the Audio Inputs table
- 8**: Power button icon

	Name	Type	Volume	Play after record	Max Time	Max Delay	Level Meter
1	AI0007(#1)	Mic	0.00 dB	<input type="checkbox"/>	40 s	60 s	
3	AI0009(#3)	Inactive	0.00 dB				
4	AI0010(#4)	Inactive	0.00 dB				
5	AI0011(#5)	Inactive	0.00 dB				
6	AI0012(#6)	Inactive	0.00 dB				

	Name	Connection	Volume	Level Meter
1	AO00015(#1)	Not Connected	0.00 dB	
2	AO00016(#2)	Not Connected	0.00 dB	

		4	Key4	Events
		5	Key5	Events
		6	Key6	Events
1	Key1	Events	7	Key7
2	Key2	Events	8	Key8
3	Key3	Events	9	Key9

Memory settings: Memory size: 8192 MB

Extension Configuration: Select Number of Extensions: 0

Zone Microphone Configuration: Mode: PTT, LOCK Timeout: 0 s

1 Name
This field enables to assign an individual name to the DMS microphone, other than the generic name assigned by the configurator.

2 Audio Inputs
The **Audio Inputs** field contains all available audio inputs in the zone microphone. Item 1 on the above figure, is a gooseneck condenser microphone – connected to the built in XLR socket.. As standard, adding a zone microphone sets the gooseneck microphone using the built in XLR as activates the main microphone. Item 2 is a jack TRS 3.5 mm type socket located on the ABT-DMS rear panel, intended for electret microphones. The system automatically detects a microphone connected to the TRS jack and disconnects the built in XLR in this event. Items 3,4,5,6 are four unbalanced linear audio inputs. Available via 3,5 mm TRS jack sockets. In one jack 3,5mm socket we have access to 2 channels – Tip: Channel 1+, Ring: Channel 2+, Sleeve 1,2. In order to activate the input, in the **Type** window change the value **Inactive** into **Line IN** on the selected input which we want to activate. Double-clicking the name of the audio input enables to change the generic name assigned by the configurator.

3 Audio Outputs – Local Output
Each zone microphone is equipped with two audio outputs. Item 1 is an output directly connected to the internal amplifier of the built-in speaker. Item 2 is a linear output, socket type TRS. Tip: out2+, Ring: out2+, Sleeve 2-. In order to activate the output, in the **Connection** window change the value from **Not connected** into **Line output**. An activated output is shown as a separate subzone in the system.

4 Logical Inputs

The **Logical Inputs** tab contains all available buttons on a zone microphone. A double click on the name of a button enables to change the generic name assigned by the configurator. The **Events** buttons transfers the programmer directly to the **EventConfiguration** tab. This allows to assign any function or event group to a selected button. A right-click on the name of a button / logical input in the **EventConfiguration** tab, as well as selection of **Go to definition**, enables to return quickly to the editing menu of the zone microphone.

5 Extension Configuration

In this window the user declares the number of connected extensions. The maximum of 5 20-button extensions can be connected to the microphone. Respectively to the selected number of extensions, the configuration window will extend to include the field for additional button name editing and ability to assign a function using the **Events** button. The extended editing field is shown below:

Logical Inputs					
			4	Key4	Events
			5	Key5	Events
			6	Key6	Events
1	Key1	Events	7	Key7	Events
2	Key2	Events	8	Key8	Events
3	Key3	Events	9	Key9	Events

6 Zone Microphone Configuration

The dedicated section for PTT button is placed on the front panel of the zone microphone function window. Apart from the **PTT** mode – Push to talk in the **Mode** option, there is a possibility to select **LOCK**, i.e. having pressed the PTT button, the microphone is active for the time defined in the **Lock Timeout** window. The maximum microphone activation time is 60 seconds. The **Start Gong** option – this enables activation of the gong having pressed the PTT button; **End Gong** will be activated after the PTT button is released.

Zone Microphone Configuration	
Mode:	PTT
LOCK Timeout:	0 s
Start Gong:	No Gong
End Gong:	No Gong
Delay:	0 ms

7 Audio input options

Activating the **play after record** option allows recording up to 40 s of a message being transmitted by the ABT-DMS and playing it back immediately after releasing the PTT button.

Name	Type	Volume	Play after record	Max Time	Max Delay	Level Meter
1 AI0037(#1)	Mic	0.00 dB	<input type="checkbox"/>			
2 AI0038(#2)	Mic		<input checked="" type="checkbox"/>	40 s	0 s	

Max time – sets the length of recorded message.

Max delay – sets the longest time the system will wait for the intended transmission zone to be freed. After the set time the message will be played back from the buffer. If the operator chooses to transmit to more than one zone, the system will play the message in all the available /free zones after the set delay time has passed and erase the message from the buffer.

Name	Type	Volume	Play after record	Max Time	Max Delay	Level Meter
1 AI0037(#1)	Mic	0.00 dB	<input type="checkbox"/>			
2 AI0038(#2)	Mic		<input type="checkbox"/>	40 s	60 s	

8 On-line mode

The online mode offers the user the possibility to view the audio level meter in real time and to adjust the mic volume level. After uploading the configuration into the system, you can enter the on-line mode by clicking the icon – it will then change it's color to green indicating active on-line mode .

13.3.9 DMS-LCD

The DMS-LCD microphone has the same configuration window as the DMS microphone. The only exception being that, to set up the messages and zones visible on the LCD touch panel you should go to the [DMS-LCD configuration](#) tab on the left side of the screen menu bar .

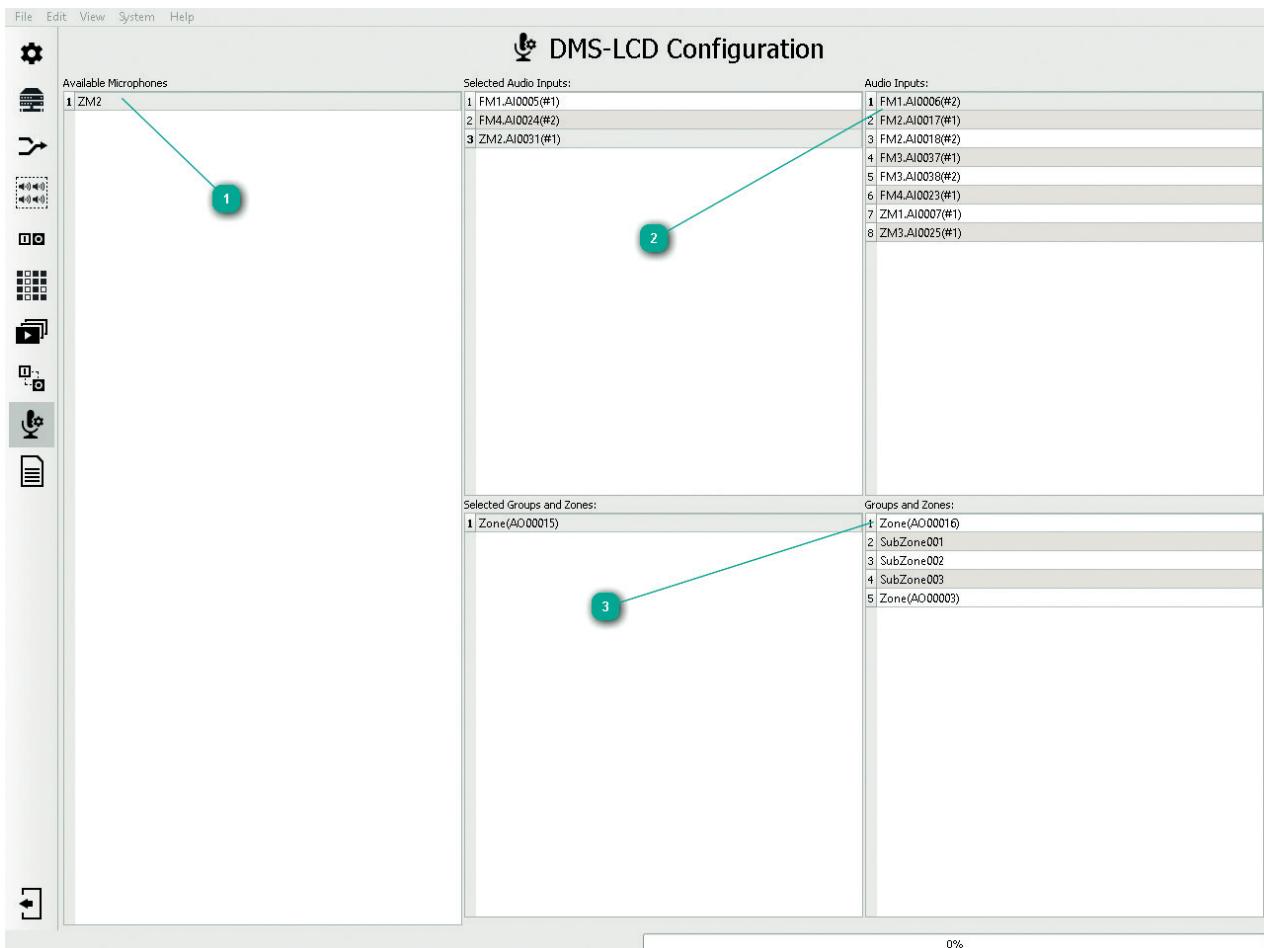

1 Available Microphones

A list of available DMS-LCD microphones in the system. Every microphone can have individually programmed access to audio inputs and zones.

2 Audio inputs

A list of defined audio sources/messages available in the miniVES system. A double-click on the chosen input source will transport it to the [Selected Audio Inputs](#) field and add it to the DMS-LCD microphone touch screen menu.

3 Groups and zones

A list of defined audio outputs/zones available in the miniVES system. A double-click on the chosen output transports it to the [Selected Groups and Zones](#) field and add it to the DMS-LCD microphone touch screen menu.

13.3.10 xCtrLine-2/4

The screenshot shows the configuration interface for the xCtrLine-2/4 system. It includes sections for HV Audio Inputs, SubZones, and Line Control Configuration. Callouts 1-6 point to specific features: 1. Name field for HV Audio Inputs; 2. Mode dropdown menu; 3. SubZone name field; 4. Signal Freq. field in Line Control Configuration; 5. Save Rev. button in Line Control Configuration; 6. On-line mode power icon.

Name	Line A	Line B	Line C	Line D
SubZone000001	<input checked="" type="checkbox"/>	<input checked="" type="checkbox"/>	<input type="checkbox"/>	<input type="checkbox"/>
SubZone000002	<input type="checkbox"/>	<input type="checkbox"/>	<input checked="" type="checkbox"/>	<input checked="" type="checkbox"/>

Line Name	Signal Freq.	Save Tol.	Set Tol.	Current Imp.	Imp. Dev.	Save Rev.
Line A	20 kHz	Save Tol.	25 %	N/A	2000 ohm	Save Rev.
Line B	20 kHz	Save Tol.	25 %	N/A	2000 ohm	Save Rev.
Line C	20 kHz	Save Tol.	25 %	N/A	2000 ohm	Save Rev.
Line D	20 kHz	Save Tol.	25 %	N/A	2000 ohm	Save Rev.

1 HV Audio Inputs

The name field enables to assign an individual name to the input intended to receive a 100 V signal from an amplifier output. The name is shown on the main AudIO-4/12 editing window, in the [Connection](#) tab.

2 SubZones / Mode:

Mode enables switching the card into following modes: [Loop](#) – the system detects short circuit / open line as well as ground leakage; [Regulator](#) – the volume control mode on the speaker line.

3 SubZones

Speaker zone editing window. It enables changing of the generic name of a zone by double-clicking the name. In addition, it is possible to define which speaker line outputs (A,B,C,D) are assigned to a given zone. Any combination is possible, however the default settings are accordant with the EN54-16, EN54-4 standards and assign two outputs per each zone.

4 Line Control Configuration / Control Method:

Speaker line supervision method window – options include: [Impedance](#) method and [Switching off](#) the speaker line supervision.

5 Save Rev.

If the system is supposed to supervise speaker lines by means of the [impedance method](#), having loaded a configuration into the system and connected a speaker line of a properly matched power and free of ground faults, load the impedance reference for a given line. In order to do this, select the [Save REV](#) button. From now on, the system properly supervises the operation of the speaker line. The [impedance method](#) continuously measures the impedance of the speaker line and if the value set in the tolerance window has been exceeded, an error is reported. The [impedance method](#) is equipped with a number of algorithms to minimize reporting untrue faults resulting from abrupt temperature changes which affect line impedance, as well as sudden changes of impedance itself. Adequate impedance measurement range on a single speaker line starts at 12.5 Ω , and ends at 10 k Ω , for measured frequency of 20 kHz. A 4-output xCtrLine-4 card (A,B,C,D) can be loaded up to 800 W of total power, the maximum load for a single speaker line is 300 W. In the case of a bridged connection of outputs A+B and C+D, the maximum tolerated power for each pair is 450 W. for a 2-output xCtrLine-2 card (A,B), the correct impedance measurement range on a single speaker line is minimum 12.5 Ω , max 10k ohm, for the reference frequency of 20 kHz. A 2-output card can be loaded up to 400 W of total power, the maximum load for a single speaker line is 300 W. In the case of a bridged connection of outputs A+B and C+D, the maximum supported power for each pair is 450 W.

6 On-line mode

The on-line mode enables to view the impedance values, as measured, as well as record reference impedance into the control card. Having loaded a configuration into the system, a single click on the left mouse button on the grey icon results in entering the real-time view mode and change of the colour of the icon into bright green . A change of tolerance, reference impedance or real-time measurement must be preceded by entering into the on-line mode.

13.4 Priority Manager Configuration

Audio Input	Component	Type	Priority	Evacuation	Coexistence Type
1 AI0005(#1)	FM1	Emergency	0		Continue After Ending
2 AI0006(#2)	FM1	BGM	300		Continue After Ending
3 AI0007(#1)	ZM1	General	200		Continue After Ending
4 AI0017(#1)	FM2	Emergency	0		Continue After Ending
5 AI0018(#2)	FM2	BGM	300		Continue After Ending
6 AI0023(#1)	FM4	Emergency	0		Continue After Ending
7 AI0024(#2)	FM4	BGM	300		Continue After Ending
8 AI0025(#1)	ZM3	General	200		Remove All After Ending
9 AI0031(#1)	ZM2	General	200		Continue After Ending
10 AI0037(#1)	FM3	Emergency	0		Continue After Ending
11 AI0038(#2)	FM3	Emergency	0		Continue After Ending
12 Evac	CU001	Emergency	10	<input checked="" type="checkbox"/> Evacuation	Continue After Ending
13 Warning	CU001	Emergency	30	<input type="checkbox"/> Warning	Continue After Ending

Each zone microphone, fireman microphone or audio input available in the system must have its priority defined in order to ensure correct operation, as intended for sound emergency systems.

1 Message priority mode in case of conflict – FIFO / LIFO

Priority Resolve Mode – this is a global system function which defines the system’s behaviour in case a conflict occurs. The conflict being a simultaneous transmission to the speaker zone from two or more audio sources of the same priority.

For **FIFO** (First in first out) – in the case when Source 1 of Priority X is transmitting to Output Y and after some time Source 2 of Priority X wants to transmit to Output Y too, Source 2 can not transmit until Source 1 has finished transmitting to Output Y.

For **LIFO** (Last in first out) – in the case when Source 1 of Priority X is transmitting on Output Y (speaker zone) and, after some time, Source 2 of Priority X will start transmitting on Output Y (speaker zone) too, then Source 2 will replace Source 1, as transmitting, and will commence transmitting to Output Y.

Priority Resolve Mode also determines the method of dynamic assignment of a backup power amplifier in case a failure occurs of the amplifier modules which are responsible for transmission of simultaneous messages of the same priorities. In case two equally prioritized messages are executed to various zones, Message 1 of Priority (100), Message 2 of Priority (100) too, which was matrixed after Message 1 – when an amplifier module failure occurs for the **FIFO** mode: the amplifier which supplies Message 1 will not be taken over by Message 2 until Message 1 (matrix) has been completed; for **LIFO** – the Message 1 amplifier module will be disconnected and assigned as a backup amplifier for Message 2.

2 Audio source type selection: **Emergency, General, Service, BGM**

The miniVES has 4 priority groups, each of the groups has 99 levels. Priorities are numbered in the reverse order: the fireman microphone in [Emergency](#) mode has the highest 0 priority the lowest priority is BGM 399.

Priority types:

[Emergency](#), range 0-99 – audio sources with the assigned priority ranged 0-99 are active only when the system is in the [Alarm Mode](#). The [Emergency](#) priority can only be assigned to the ABT-DFMS fireman microphone, messages recorded on memory cards and control unit audio inputs.

[Service](#), range 100-199 – can be assigned to every audio source type and does not allow matrix activation in the [Alarm Mode](#). A loss of the 230 V AC basic power supply does not deactivate [Service](#)-type source messages. Sources of priorities contained within this group are subject to the [Zone\(s\)off](#) function.

[General](#), range 200-299 – can be assigned to zone microphones and messages. It does not operate in the alarm mode and in case of a loss of the 230 V AC basic power supply. Sources of priorities contained within this group are subject to the [Silence](#), [Power Save](#) and [Zone\(s\)off](#) functions.

[BGM](#), range 300-399 – assigned only to audio inputs located in control units and zone microphones. BMG-priority audio source Matrices do not operate in the alarm mode and in case of a loss of the 230 V AC basic power supply. Sources of priorities contained within this group are subject to the [Silence](#), [Power Save](#) and [Zone\(s\)off](#) functions.

As standard, the configuration software assigns arbitrarily priorities from the [Emergency](#) group, depending on the audio source, that is:

1. For the ABT-DFMS fireman microphones – the [Emergency](#) Priority NB 0-10 is the highest priority pool reserved only for these devices.
2. Sound messages played back from system memory cards for the [Emergency](#) Priority [Evacuation](#) checkbox – these are assigned a value ≥ 10 .
3. Sound messages played back from system memory cards for the [Emergency](#) Priority [Warning](#) checkbox – these are assigned a value ≥ 30 .
4. For the remaining audio inputs on control units with a possibility of being assigned the [Emergency](#) Priority [Evacuation](#) checkbox – these are assigned a value ≥ 20 , and for the [Warning](#) option ≥ 40 .

3 Audio source description

The [Audio Input](#) and [Component](#) items indicate specifically which audio input, zone microphone, fireman microphone or message a selected priority is assigned. The [Component](#) tab informs of the location in which a given message was recorded and will be played back from or – in case of audio inputs – specifies the device in which the selected input is located.

4 Zone retained signalling mode, **Evacuation / Warning modes**

Having assigned the [Emergency](#) mode to any audio source, the [Warning](#) checkbox appears in the right corner. This means that as the initial setting for the [Evacuation](#) mode, in case of transmitting a message on a given zone, on the RGB button diode programmed as the [Select Zone](#) of this zone, the red LED will be blinking. Ticking the checkbox is equivalent to changing the mode to [Evacuation](#) which results in the RGB LED – the red one – being on during a message transmission.

5 Priority group filtering

The filtering tool enables to display all audio sources from a selected priority group. To do this, click the left mouse button once on the [All Types](#) tab. This will result in options dropped down, then select a group and confirm activation of the filter by clicking [Apply Filters](#).

6 Coexistence type



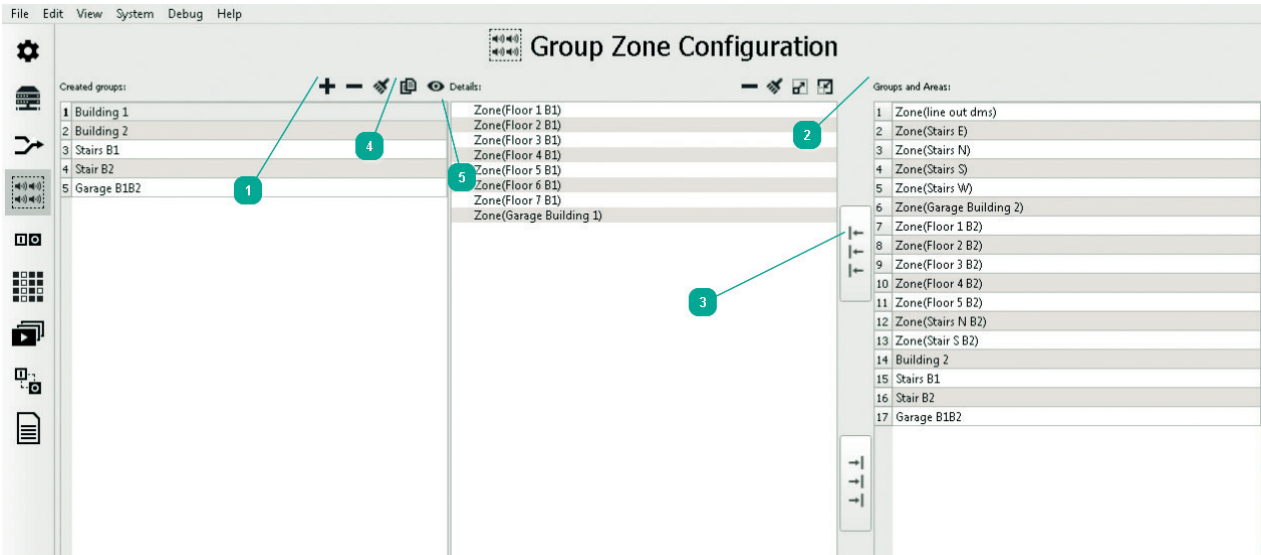

This function defines the systems behaviour when an incoming message has superseded the message occupying this zone at the moment. If the superseding message / audio source is defined as [Continue After Ending](#) it means that the system will return to transmitting the previous (lower priority) message after a higher priority message has ended. If the superseding message / audio source is defined as [Remove All After Ending](#) then after the end of the higher priority (superseding) message, the lower priority message will not be restored.

13.5 Group Zone Configuration



This function is available only from the advanced configurator level – [Basic Configuration](#) – [Configuration Mode](#) – [Advanced](#). It is used to combine any predefined speaker lines / zones into one. A group created in this way has the same functionalities in the system as a single zone.

In order to create a new group, the following must be done:

- 1 **Using the + icon**, a new group is created whose generic name is ZoneGroup0000x; the name is editable by moving the mouse cursor over it and pressing the left mouse button.
- 2 From the **Group and Areas** tab, the column on the right hand side of the screen, move the mouse cursor over available **Subzones, Zones** and add elements to the group by double-clicking of the left mouse button.
- 3 It is also possible to add all available subzones and zones by means of the dedicated icon .
- 4 **Group cloning function: Clone Group** – this is available under the icon . Highlight the previously created group by moving the mouse cursor over its name and by clicking the left mouse button once. Then select the icon . **Clone group** results in creating a new group of the identical composition as the source group.
- 5 **Group element graphic view: Preview Group** – this is available from the icon . This function presents, in a graphic form, in one table, all groups which have been created, as well as their members.

	Zone(Floor 1 B1)	Zone(Floor 1 B2)	Zone(Floor 2 B1)	Zone(Floor 2 B2)	Zone(Floor 3 B1)	Zone(Floor 3 B2)	Zone(Floor 4 B1)	Zone(Floor 4 B2)	Zone(Floor 5 B1)	Zone(Floor 5 B2)	Zone(Floor 6 B1)	Zone(Floor 7 B1)	Zone(Garage Building 1)	Zone(Garage Building 2)	Zone(Stair S B2)	Zone(Stairs E)	Zone(Stairs N B2)	Zone(Stairs N)	Zone(Stairs S)	Zone(Stairs W)
Building 1	●		●		●		●		●		●		●							
Building 1_1	●		●		●		●		●		●		●							
Building 2		●		●		●		●		●		●		●	●		●			
Garage B1B2													●	●						
Stair B2															●			●	●	●
Stairs B1																●		●	●	●

13.6 Control I/O Configuration

This tab is only available from the advanced configurator level – [Basic Configuration](#) – [Configuration Mode](#) – [Advanced](#). The tab consists of 3 pages: [Group Logical Inputs](#), [Group Logical Outputs](#) and [Timers](#).

13.6.1 Group Logical Inputs

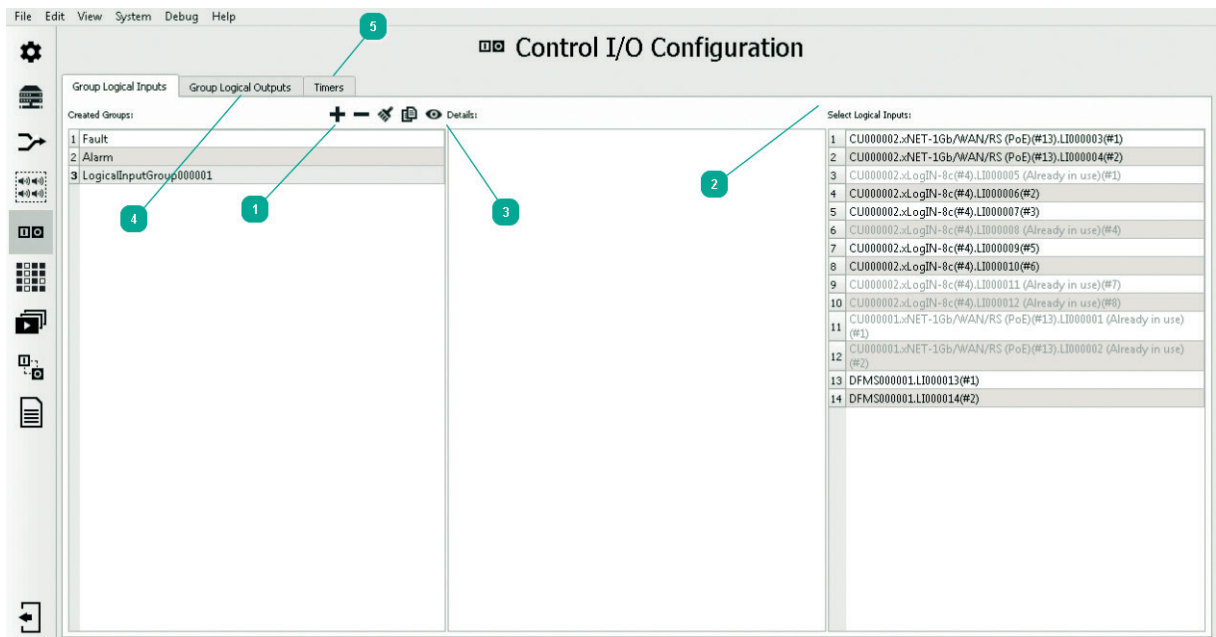

Group Logical Inputs – this is grouping two or more logical inputs in order to trigger action in the system for a specified condition. **In order to create a group:**

- 1 Using the **+** icon, create a new group with the generic name LogicalInputGroup0000x; the name is editable by moving the mouse cursor over it and pressing the left mouse button.
- 2 From the **Select Logical Input** tab, using the left mouse button, add elements to the group. Each of the elements can only be assigned to one group.

The created group is shown in the [Event Configuration](#) tab, in the [Input](#) tab. For a logical input group, execution of the action, as assigned to the group, is determined by fulfilling the [Condition](#) from the [Event Configuration](#) tab. [Condition](#) value =1, =0, = decimal value, < decimal value, > decimal value, <= decimal value, >= decimal value. The decimal value entered is to be interpreted in the following way – each group member has an item assigned: the first added element in the middle table from the [Control I/O Configuration](#) tab – [Group Logical Inputs](#) comprises the bit of the smallest weight, found in the digital word, rightmost. The last element from the group is the bit of the biggest weight, leftmost. A binary number created in this way must be translated into the decimal system and entered into the condition.

For [NO](#) (Normally Open) [Default Logical Inputs](#) – 1 is input closing, 0 – opening. [NC](#) (Normally Closed) [Default Logical Input](#) – 1 is input opening, 0 – closing. If we want to programme a logical input group, e.g. Input 1 NO, Input 2 NO, to trigger any function following closing of both inputs, enter the condition = 3 (11 in the binary numeral system).

In case of a 2-input group, we have the following condition options:

- 00 = 0 Opening of both inputs,
- 01 = 1 Closing of Input 1 and opening of Input 2,
- 10 = 2 Opening of Input 1 and closing of Input 2,
- 11 = 3 Closing of both inputs;

If we have a group of 3 logical inputs, Input 1 – NO, Input 2 – NO, Input 3 – NO, we have the following condition options:

100 = 4 In 1 open, In 2 open, In 3 closed
 101 = 5 In 1 closed, In 2 open, In 3 closed
 110 = 6 In 1 closed, In 2 closed, In 3 closed
 111 = 7 In 1 closed, In 2 closed, In 3 closed

- 3 **Group element graphic view: Preview Groups** – this is available under the icon . This function presents, in the form of a graphic matrix, in one table, all groups which have been created, as well as their members.

	D1000001	D1000002	D1000003	D1000004	Key000001	Key000002	Key000003	Key000004	Key000005	Key000006	Key000007	Key000008	Key000009	L1000001	L1000002	L1000003	L1000004	L1000005	L1000006	L1000007	L1000008	L1000009	L1000010	L1000011	L1000012	L1000013	L1000014
Alarm																											
Fault																											
LogicalInputGroup000001																											

- 4 **Group Logical Outputs** – this is grouping of two or more logical (relay) outputs in order to simplify assignment of many relay inputs to a given event in the system.
- 5 **Timers**
The Timers functions serves to create elements triggering given actions in the minVES system, using time dependences.

13.6.2 Group Logical Outputs

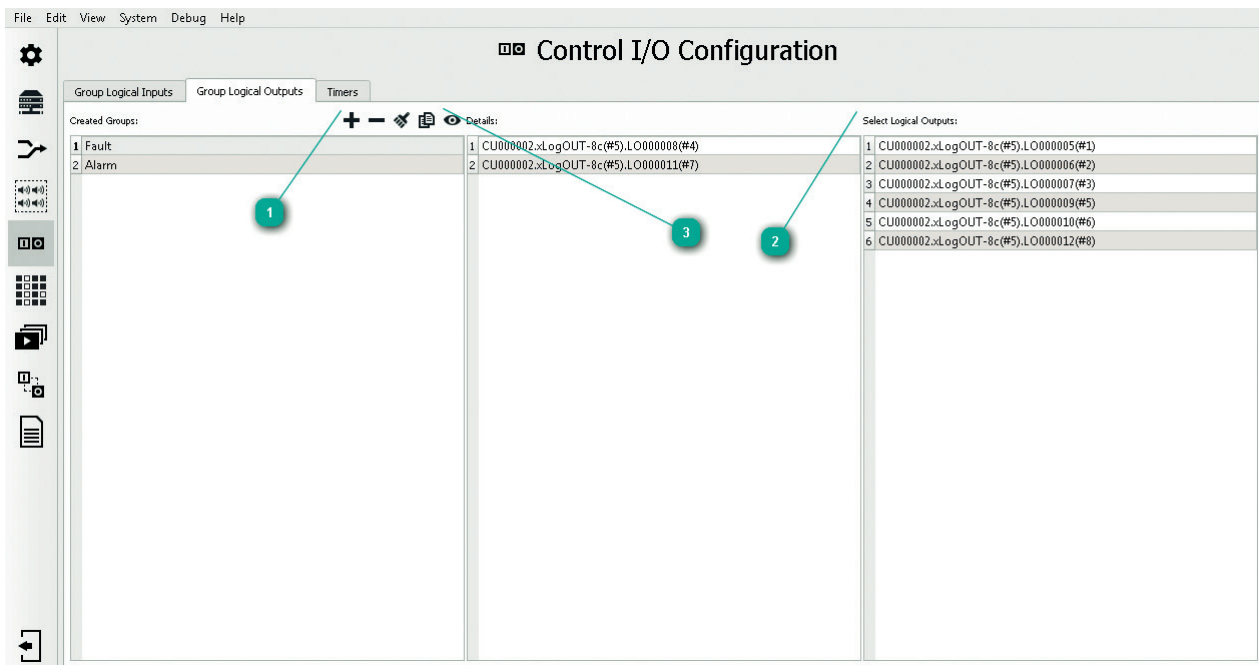

Group Logical Outputs – this is grouping of two or more logical (relay) outputs in order to simplify assignment of many relay inputs to a given event in the system:

- 1 **Using the + icon**, create a new group with the generic name LogicalOutputGroup0000x; the name is editable by moving the mouse cursor over it and pressing the left mouse button.

13.6.3 Timers

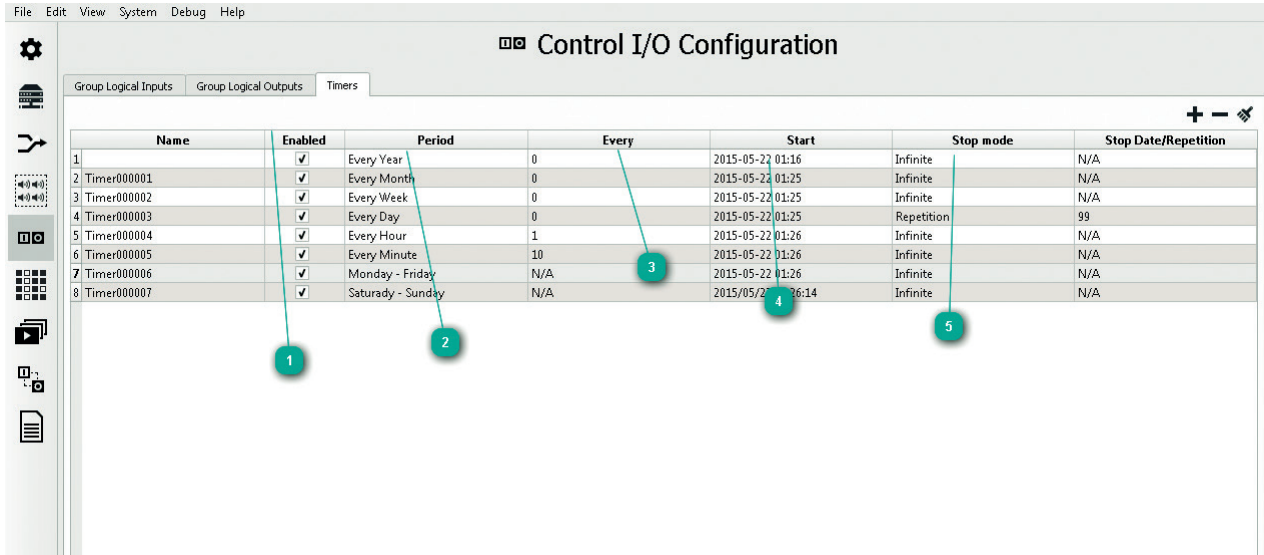

	Name	Enabled	Period	Every	Start	Stop mode	Stop Date/Repetition
1		<input checked="" type="checkbox"/>	Every Year	0	2015-05-22 01:16	Infinite	N/A
2	Timer000001	<input checked="" type="checkbox"/>	Every Month	0	2015-05-22 01:25	Infinite	N/A
3	Timer000002	<input checked="" type="checkbox"/>	Every Week	0	2015-05-22 01:25	Infinite	N/A
4	Timer000003	<input checked="" type="checkbox"/>	Every Day	0	2015-05-22 01:25	Repetition	99
5	Timer000004	<input checked="" type="checkbox"/>	Every Hour	1	2015-05-22 01:26	Infinite	N/A
6	Timer000005	<input checked="" type="checkbox"/>	Every Minute	10	2015-05-22 01:26	Infinite	N/A
7	Timer000006	<input checked="" type="checkbox"/>	Monday - Friday	N/A	2015-05-22 01:26	Infinite	N/A
8	Timer000007	<input checked="" type="checkbox"/>	Saturday - Sunday	N/A	2015/05/22 06:14	Infinite	N/A

This is a function used to create elements activating given actions in the miniVES system. In order to create a timer, click the **+** icon in the [Control I/O Configuration – Timers](#) tab. In this way a timer is created with the generic name Timer00000x; the name is editable by moving the mouse cursor over it and pressing the left mouse button. **Each timer has the following set of parameters:**

- 1 **Enabled (checkbox)** – Timer activity window. It is used to deactivate the timer if we do not want a given event, which is triggered by the timer, to be executed, and we do not want to remove the event from the system, then to do this we deactivate a selected timer.
- 2 **Period – activation period:**
 - > [annual](#)
 - > [monthly](#)
 - > [weekly](#)
 - > [daily](#)
 - > [hourly](#)
 - > [minute](#)
 - > [\(Monday through Friday\)](#)
 - > [\(Saturday & Sunday\)](#)
- 3 **Every** – the time interval number between the activations depending which parameter is selected from the **Period** window. If [Every Minute](#) is selected and the **Every** parameter is set to 15, this means activation of the timer every 15 minutes.
- 4 **Start** – defines the exact date and time of the first activation of the timer.
- 5 **Stop** – defines ending the operation of the timer, the available options being:
 - > [To date](#) – the date and time to end activation
 - > [Infinite](#) – activation without defining the end
 - > [Repetition](#) – the exact specification of the number of repetitions

A defined timer is available in the [Event Configuration](#) tab, in the **Input** column, and all system functions can be assigned to it, as to zone microphone or logical input buttons.

13.7 Matrix Configuration

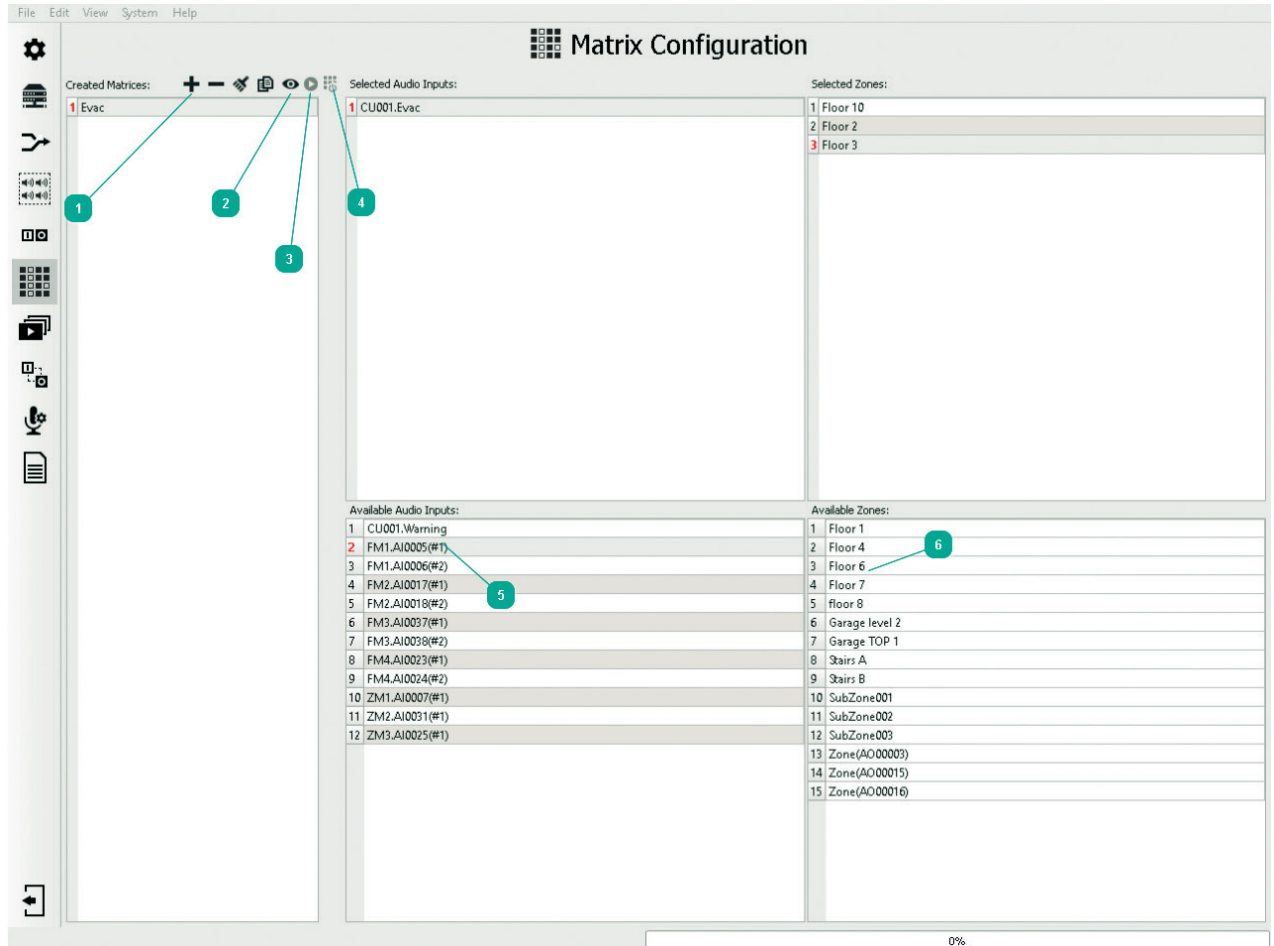

Matrix Configuration is used to create connections of all audio sources available in the system to audio outputs.

The tab has 3 sections: creating Matrices, audio sources and speaker zones or zone group.

1 Matrix editing tab

By means of the icon **+**, a new matrix is created with a generic name which can be change by double-clicking of the left mouse button on the matrix name. Creating the first matrix in the system, we activate the available audio source and available speaker zone field.

Icon **-** results in deleting the marked matrix completely.

Icon **✖** deletes all previously created matrices.

Matrix cloning function: Clone Matrices – this is available under the icon **📄**. Highlight the previously created matrix by moving the mouse cursor over its name and by clicking the left mouse button once. Then select the icon **📄**. **Clone Matrices** results in creating a new matrix of the identical composition as the source matrix.

2 Matrix element graphic view: Preview Matrices – this is available under the icon **👁**. This function presents, in the form of a graphic matrix, in one table, all created connections of audio sources to the selected matrix outputs. Moving the mouse cursor over the matrix name and clicking the left mouse button once results in displaying the elements of a selected matrix in the **Preview Matrices** table. The output from the **Preview** mode is executed by a single click of the left mouse button on the icon **👁**.

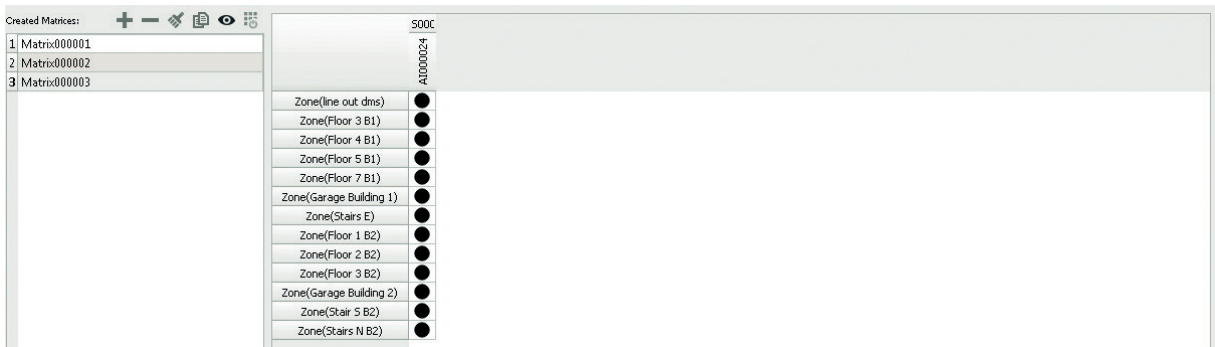

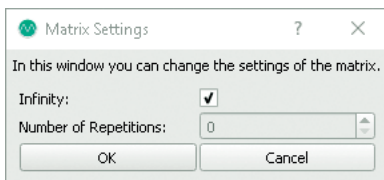

- 3 **Matrix settings** – the number of message repetitions specific to the matrix is accessible under the icon . If the **Infinity** checkbox is ticked the message is played back in a continuous loop. Untick the checkbox to gain access to setting the number of repetitions of the message with the maximum number being 100.



- 4 **Test dynamic matricing** – available under the icon .

This is a service function which enables creation of dynamic audio connections from the configurator for testing/servicing purposes. This option is active only if and when the system has a configuration loaded and the computer with the configuration software is connected to the system and has the same configuration as the system. Setting a connection is executed by selecting an audio source from the first column – a single click of the left mouse button, and then selecting a speaker zone from the second column – a single click of the left mouse button, followed by selection of the .

The  icon deletes all single connections, whereas selecting the  icon deletes all connections which have been set.

- 5 **Available Audio Inputs**

Audio sources available in the entire system. Double-click a chosen audio source to transport it to the **Selected Audio Inputs** field.

- 6 **Available Zones**

Available speaker zones, as declared in the system. Double-click a chosen speaker zone to transport it to the **Selected Zones** field.

In order to create a matrix correctly:

1. **Create a matrix by selecting the  icon.**
2. **Select an audio source** – a double click of the left mouse button on any element from the available audio input list.
3. **Select a zone** – a double click of the left mouse button on any element from the available zone list. Remember that it is possible to assign only one audio source to a given zone within one matrix. Adding another audio source within one matrix makes any previously used zones unavailable for successive sources as they are already used with previously defined audio inputs.

13.8 Scenario Configuration

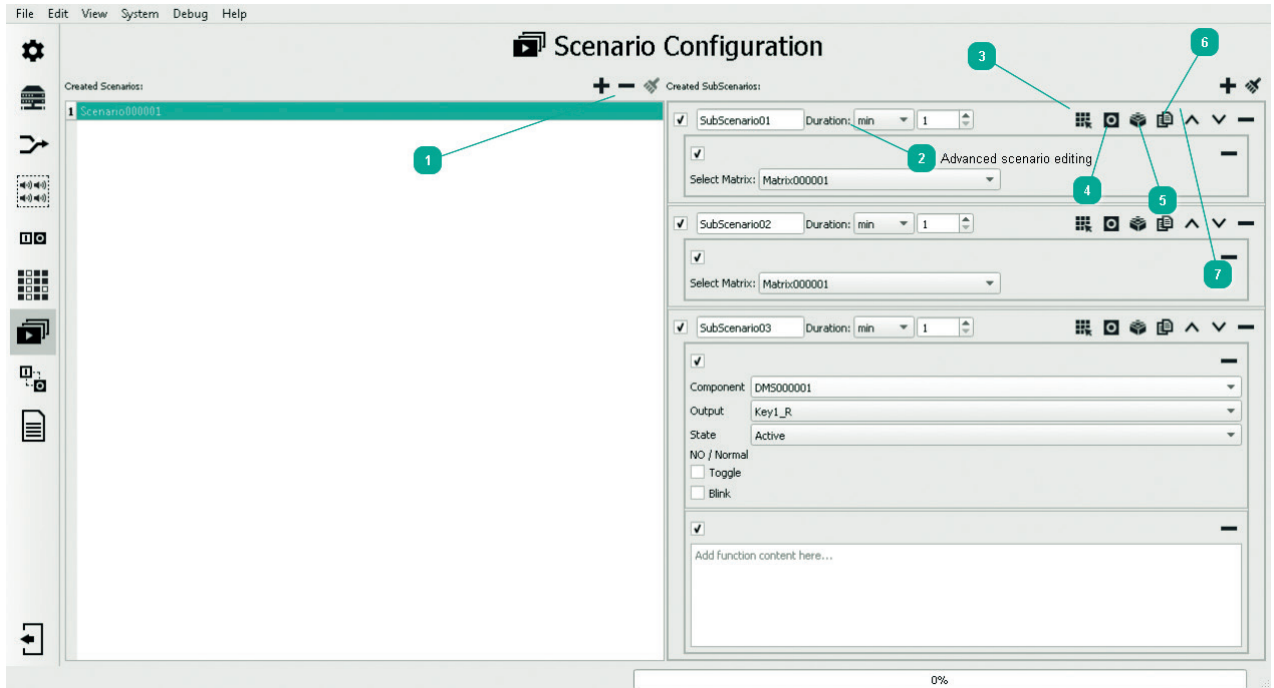

Scenario Configuration – this enables to create an event sequence that is time-limited in any way and executed one by one (SubScenario after SubScenario). Scenarios can consist of matrixes, logical (relay) outputs and individually created functions in the LUA language.

- 1 **Scenario editing tab** enables to create new scenarios, changing their names and deleting selected ones.

By means of the icon , a new scenario is created, whose generic name can be changed by double-clicking the left mouse button on the scenario name.

Icon  results in deleting the marked scenario completely.

Icon  deletes all previously created scenarios.

- 2 **Advanced scenario editing**

Each subscenario has a predefined duration (**Duration**). Available options include as follows:

- > [ms](#) – millisecond (1000 ms = 1 second)
- > [s](#) – second
- > [min](#) – minutes
- > [hours](#)
- > [days](#)
- > [weeks](#)
- > [years](#)
- > [infinite](#) (no end defined)

- 3 **Icon  adds a matrix or a number of matrixes to a subscenario.** It must be remembered that after the **Duration** time has expired, counting from activation of a given scenario, the created matrixes are deactivated.

- 4  assigns available logical (relay) outputs to a subscenario. Having added a logical output, the following windows are to be filled:

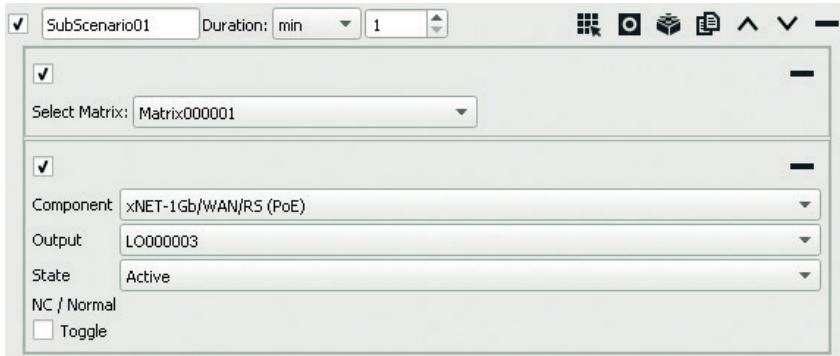



Component – select an output card or fireman microphone, a communications card containing the output we want to use.

Output – select from the list of available outputs on the device, from the **Component** tab, the output which we want to control.

State – allows to determine the final state of the relay contacts following activation. **Active** results in changing the relay state to the opposite one on execution of a scenario. For **Inactive**, the relay does not change its state when the scenario is activated.

NC/ Normal (Inverse) – informs of the initial state of a relay before activation of the function. If we set **Active** in the **State**, then activation of the scenario for an **NC/Normal** relay causes transition into **NO** – Normally Open. It must be remembered that after the **Duration** time has expired, as counted from activation of a given scenario, the assigned logical outputs remain in the state as defined in the subscenario. They do not return to the default settings.

By marking the **Toggle** option causes that each time when the output assigned to a scenario is activated, then the relay state changes into the opposite to the one which was set at an earlier activation. The default state at the first activation depends of the **State** field settings.

- 5  **Add Custom Action** – an editor window in which one's own system function can be written in the LUA scripting language.
- 6 **Subscenario cloning function: Clone Subscenario** – this is available under the icon . A single click of the left mouse button on the icon creates a new subscenario of the identical composition as the one created before.
- 7 **Up / Down arrows**  – enable to change the order in which scenarios are executed. The order of subscenario execution by the system is top to bottom according to the times, as declared in the **Duration** window.

13.9 Event Configuration

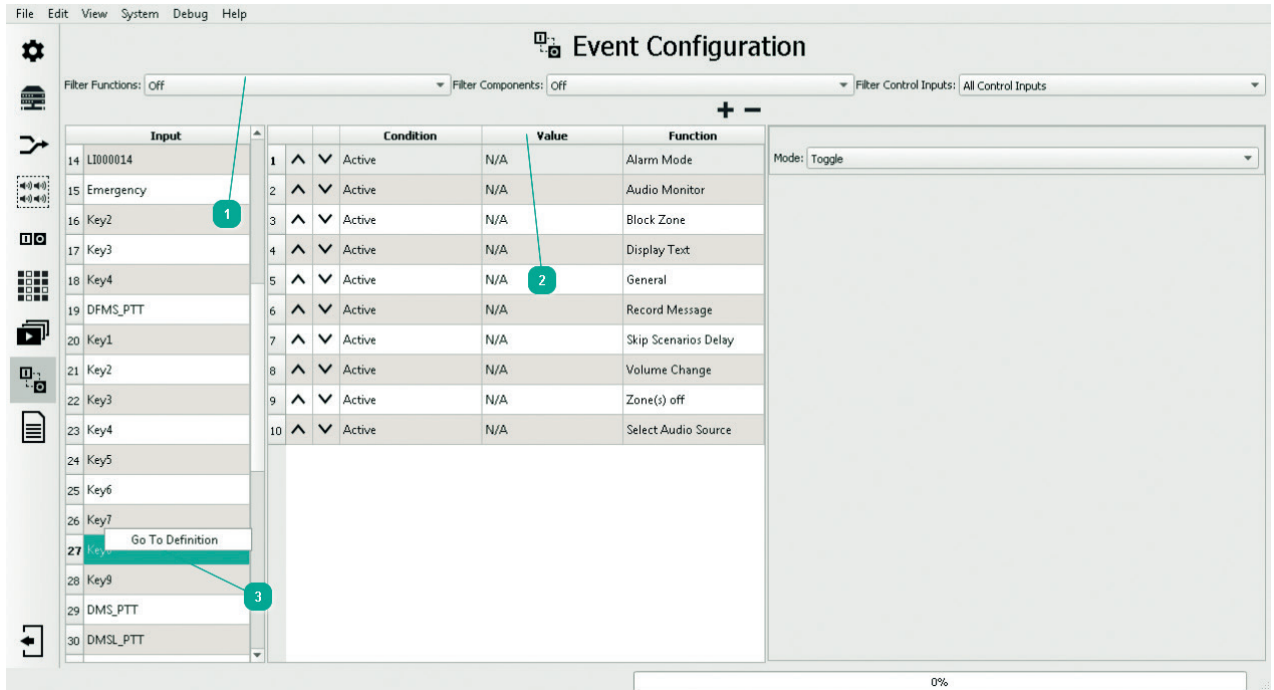

Event Configuration – this tab enables assignment of a selected system function to each logical input and button available on fireman and zone microphones, as well as scenario and matrix activation / deactivation. Moreover, in the [Event Configuration – Inputs](#) tab there are 4 system States available, to which one can assign any function, matrix, scenario, as well as define activation of relay outputs.

The signalled system states include as follows:

- » **Alarm Mode** – will activate an assigned action upon the system entering the alarm mode.
- » **Error** – will activate an assigned action upon detection of an error in the system.
- » **Blocking** – activation of an action when blocking a single speaker zone.
- » **Backup power** – activation of an action subsequent to the central unit detecting a 230 V AC power failure and switching to the emergency power source (batteries).

Assignment of any system function / action triggered by one of the above system states has been created to facilitate state signalling on any available element of the system, e.g. any output on a logic output card.

Input	
1	Alarm mode
2	Error
3	Blocking
4	Backup Power

1 The filters in the [Event Configuration](#) tab enable to search for any logical input or button sorted by the assigned function – [Filter Functions](#), sorted by the device containing the given element – [Filter Components](#) or by using available inputs – [Filter control inputs](#).

2 **In order to assign a function to any button or logical input:**

1. Select an element from the [Inputs](#) list by single-clicking the left mouse button on the element name.

Input	
1	LI000003
2	LI000004
3	LI000005 (In Group)
4	LI000006
5	LI000007
6	LI000008
7	LI000009
8	LI000010

2. Click the left mouse button once on the icon , and then select an appropriate function from the [Functions](#) column in the window. It is possible to assign many function to one button or logical input.

3 [Go to Definition](#) is a quick access function which is activated by clicking the right mouse button while moving over onto the name of a logical input and any button in the [Event Configuration](#) – [Inputs](#) tab. The function results in going to detailed editing of the microphone, card, microphone extension, device in which the element being edited is located.

13.9.1 Functions

Input	Condition	Value	Function
1 Key1	1 ^ v Active	N/A	Alarm Mode
2 Key2	2 ^ v Active	N/A	Audio Monitor
3 Key3	3 ^ v Active	N/A	Block Zone
4 Key4	4 ^ v Active	N/A	Custom
5 Key5	5 ^ v Active	N/A	Display Text
6 Key6	6 ^ v Active	N/A	Failure Accept
7 Key7	7 ^ v Active	N/A	Failure Delete
8 Key8	8 ^ v Active	N/A	General
9 Key9	9 ^ v Active	N/A	Intercom
10 DMS_PTT	10 ^ v Active	N/A	LED Test
	11 ^ v Active	N/A	Mute Audio Source
	12 ^ v Active	N/A	Power Save
	13 ^ v Active	N/A	Record Message
	14 ^ v Active	N/A	Scenario Delay
	15 ^ v Active	N/A	Select Audio Source
			Select Zone
			Silence
			Skip Scenarios Delay
			StandBy
			Start / Stop Matricing
			Stop Scenario
			Volume Change
			Zone(s) off

Alarm Mode

The alarm mode function results in the system entering into a detected threat warning and evacuation mode. In this mode, fireman microphones and evacuation-type messages are active. All the other sources: BGM, General, Service, are inactive until the system goes out of the alarm mode. More information of assigning type to a sound source, message or zone microphone is to be found in the [Priority Manager](#) tab. The [Alarm Mode](#) can be activated in many ways. Most frequently by the dedicated [Evacuation](#) button on the fireman microphone or any programmable logic input located on the miniVES central unit, on the xNET-1Gb/WAN/RS communications card and the fireman microphone. The function itself may operate in three available modes: [Start](#), [Stop](#) and [Toggle](#).

Audio Monitor

The audio monitor function enables to hear a message/audio signal, as transmitted, in any zone on the built-in speaker of the ABT-DMS and ABT-DMS-LCD zone microphones. In order to programme the function in the miniVES, select a zone which we want to preview from the [Source zone selection](#) window and from the [Target zone selection](#) window below select the zone to which the zone microphone internal speaker is assigned. In order to activate the zone microphone speaker output enter the [Zone microphone configuration](#) window in the [Audio outputs](#) table, from the first line in the [Connections](#) field select the [Output line](#). Having switched from [No connection](#) to [Output line](#), the system creates a zone whose generic name is editable in the [Name](#) window. In this way a zone has been created consisting only of a zone microphone built-in speaker which is available in the [Matrices configuration](#) tab, as well as for all functions referring to speaker zones, including the audio monitor.

Block Zone

This function can have one or many zones assigned to it. Blocking a zone results in a total lack of possibility to transmit sources to a zone or zone group, regardless of the source type. The block zone is signalled by a constant, yellow LED on the button programmed as [Zone selection](#) having the highest signalling priority.

Custom

The window of this non-standard function enables to create, programme one's own function or series of actions for the system to execute. The code of the programme which is to be placed in the [Custom](#) field must be consistent with the syntax of the LUA language and refer to variables, functions and libraries defined by the Ambient System in the LUA language implementation instructions in the miniVES system.

Display Text

Activation of the display text function opens a dialogue box on a selected and available GUI screen in the system and prompts display of the text entered into the [Text to display](#) window.



Failure Accept

This is a global function which mutes the acoustic signalization of a failure within the entire system. The moment any failure occurs in the system, the yellow LED on the failure accept button blinks additionally on each element of the system equipped with a GUI, the buzzer goes off as well. Having accepted the failure, the yellow LED is lit and the persistent acoustic signal stops.

Failure Delete

Deleting a failure is a global function affecting the entire system. The function is active only if and when the system is in the failure status. Activation of the [Failure delete](#) results in resetting of the system element in which the failure was detected, and then running the system test procedure.

General

This function combines three main functionalities of the miniVES system: [Scenarios](#) , [Matrices](#)  and [logical outputs](#) , alongside an access to RGB LED behaviour programming on zone microphones. The [General](#) function enables to assign to a logical input or a button of any defined scenario, matrix combination, alongside a possibility to define system LED and logical output activation in an individual way.

If in the [General](#) function, the icon  is selected, then this function is assigned a matrix. Activation of the general function enables to activate or deactivate one or multiple matrices defined in the system, using one logical input or button on a zone/fireman microphone. Each matrix can have an individual activation mode assigned to it – [start](#) / [stop](#) / [toggle](#).

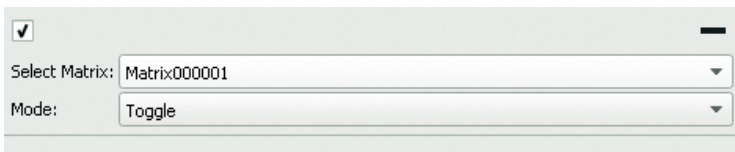

If in the [General](#) function, the icon  is selected, then this function is assigned a scenario. Activation of the general function enables to activate or deactivate scenarios using one logical input or button on a zone/fireman microphone. Each scenario can have an individual activation mode assigned to it – [start](#) / [stop](#) / [toggle](#).

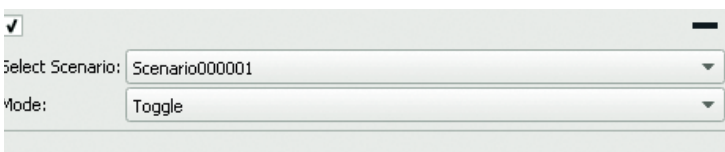

If in the [General](#) function, the icon  is selected, then this function is assigned a selected logical/relay output. The figure below presents the options, as available:



[Component](#) – enables to select an output card or fireman microphone from the list, a communications card containing the output we want to use.

Output – enables to select from the available output list on the device, from the **Component** tab, an output which we want to control.

State – allows to determine the final state of the relay contacts following activation. **Active** results in changing the relay state to the opposite one on execution of the **General** for **Inactive**, the relay does not change its state when the **General** is activated.

NC/Normal (Inverse) – this field informs of the initial state of a relay before activation of the function. If we have **Active** in the **State**, then activation of the **General** function for an **NC/Normal** relay causes transition into **NO** – Normally Open. If we have **Active** in the **State**, then activation of the **General** function for an **NC/Invers** will cause transition into **NC** – Normally Closed.

By marking the **Toggle** option causes that each time when the output assigned to the **General** is activated by such a system element as a logical input or button on a zone microphone, the relay state changes into the opposite to the one which was set at an earlier activation. The default state at the first activation depends of the **State** field settings.

Latch

Marking the **Latch** option results in a relay output changing its status to the opposite one than specified in the information field located below the **State** tab (see Figure below) on the first activation of the **General** function.

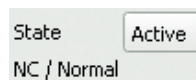

The relay does not change its state into the opposite one, does not return to the settings defined in the relay information field on deactivation of the **General** function.

Intercom

This function sets up an intercom connection between two microphones available in the system. The **Select microphone from** field is automatically migrated by the device containing the key we are assigning the intercom function to. In the **Select microphone to** field the recipient of the intercom connection should be chosen. The **Enable sound when call appears** checkbox lets the user define the acoustic signals for the connection, **Select the sound for initialization of call** being the sound we hear while waiting for the recipient to answer the call on the device that initializes it. The **Select sound for incoming call** field defines the sound we hear on the device being a recipient of an awaiting connection.

LED test

The LED test function activates all LEDs on the element to which it is assigned. In addition, activation of this function on the fireman microphone triggers the warning buzzer signal. The function can be activated in three modes.

Mute audio source

This function mutes one selected audio source in all matrices to which it is assigned. In the **Source selection** window, select from the available and defined audio inputs, microphones and messages in the system to define the function correctly. Stopping the **Mute audio source** function results in turning up the audio source volume to the full level and restoring the matrices to the state before activation of the mute function.

Power Save

The power save function disconnects all active BGM and General-type sources. The function is activated by dynamic assignment. The function can be activated in three modes. Deactivation of the **Power Save** function results in restoring the previously disconnected sources.

Record Message

This function is used to record messages directly from the ABT-DMS, ABT-DMS-LCD zone microphones without having to connect to the system via dedicated software and during the system's normal operation. Messages are recorded in the flash microSD memory on the control unit to which the zone microphone is directly connected. Message recording is signalled by a red LED at the **Record Message** button. The function records a message into a file whose name is defined in the configurator, in the **Message** window. In case of filling up the memory, this is signalled by a yellow LED. Replaying of a recorded message is executed via the **Select Audio source** function for which one of the predefined names is assigned from the list: Message1, Message2, Message3.

Selector - active mode (Best_overload_1ymf)

File Edit View System Help

Amplifier Output Manager

Name of element	Select all zones to set power	Assigned Power Load [W]	Replace Power	Power [W]	Impedance [ohm]	Total Power	Allocated Buses	Available Power [W]	Status
System (Global Settings)									
JK3	<input type="checkbox"/>	30 [W]	Set Speaker Zones Power 100 %	Read					
JK4	<input type="checkbox"/>	CU BUS Total Power: 0 [W]	←	Read		BUS Total Power: N/A	1	160 [W]	This unit uses HV individual Amplifiers.
JK1	<input type="checkbox"/>	CU BUS Total Power: 0 [W]	←	Read		BUS Total Power: N/A	1	160 [W]	This unit uses HV individual Amplifiers.
JK7	<input type="checkbox"/>	CU BUS Total Power: 460 [W]	←	Read		BUS Total Power: 480	3	160 [W]	
JK8	<input type="checkbox"/>	CU BUS Total Power: 1500 [W]	←	Read		BUS Total Power: 1500	3	500 [W]	
JK8 Slot #1 (xCtrlLine-44)									
Total Card Power: 375 [W]									
Line A (AO_IK8_1A)		200	Replace	491	20				WARNING - The measurement power exceeds the maximum line power
Line B (AO_IK8_1B)		110	Replace	Out of range	3916				WARNING - Measured power out of range. Value < 5 W
Line C (AO_IK8_1C)		50	Replace	Out of range	8500				WARNING - Measured power out of range. Value < 5 W
Line D (AO_IK8_1D)		15	Replace	Out of range	Out of range				WARNING - Measured power out of range. Value < 5 W
JK8 Slot #2 (xCtrlLine-44)									
Total Card Power: 375 [W]									
Line A (AO_IK8_2A)		200	Replace	-	-				WARNING - Download of the data was not possible.
Line B (AO_IK8_2B)		110	Replace	-	-				WARNING - Download of the data was not possible.
Line C (AO_IK8_2C)		50	Replace	-	-				WARNING - Download of the data was not possible.
Line D (AO_IK8_2D)		15	Replace	-	-				WARNING - Download of the data was not possible.
JK8 Slot #3 (xCtrlLine-44)									
Total Card Power: 375 [W]									
Line A (AO_IK8_3A)		200	Replace	Out of range	Out of range				WARNING - Measured power out of range. Value < 5 W
Line B (AO_IK8_3B)		110	Replace	Out of range	Out of range				WARNING - Measured power out of range. Value < 5 W
Line C (AO_IK8_3C)		50	Replace	10	954				WARNING - Measured power out of range. Value < 5 W
Line D (AO_IK8_3D)		15	Replace	5	1863				
JK8 Slot #4 (xCtrlLine-44)									
Total Card Power: 375 [W]									
Line A (AO_IK8_4A)		200	Replace	Out of range	Out of range				WARNING - Measured power out of range. Value < 5 W
Line B (AO_IK8_4B)		110	Replace	Out of range	Out of range				WARNING - Measured power out of range. Value < 5 W
Line C (AO_IK8_4C)		50	Replace	Out of range	Out of range				WARNING - Measured power out of range. Value < 5 W
Line D (AO_IK8_4D)		15	Replace	Out of range	Out of range				WARNING - Measured power out of range. Value < 5 W
JK2	<input type="checkbox"/>	CU BUS Total Power: 620 [W]	←	Read		BUS Total Power: 640	4	160 [W]	
JK6	<input type="checkbox"/>	CU BUS Total Power: 20 [W]	←	Read		BUS Total Power: 320	2	160 [W]	
JK5	<input type="checkbox"/>	CU BUS Total Power: 40 [W]	←	Read		BUS Total Power: 640	2	320 [W]	

Scenario Delay

This function cause a time delay in the scenario execution. The maximum time to declare a delay in a scenario execution is 600 seconds. In order to execute the scenario with a delay, activate the scenario delay function and then activate scenario execution via the [General](#) function. The period of the delay from the moment of activation of a scenario is signalled by a purple LED blinking.

Select audio source

This function enables easy execution of the [dynamic matricing](#) function. Dynamic matricing consists of creating a matrix (combining a source to speaker lines) from a zone microphone or GUI in any configuration according to the user's current needs. The following items can be assigned as an audio source: messages, fireman microphones and all available zone microphones and their audio inputs. In order to initiate dynamic matricing, select dedicated [Zone selection](#) buttons in the given order: highlight the zone or zone group to which we want to transmit to, then – using the [Source selection](#) button – initiate transmission of the programmed source into the selected zones.

Select Zone

The zone selection function serves to assign one zone or a zone group to a selected button. Having selected the function in the configurator, assign the selected zone in the [Select Zone](#) field, and then select one of the activation modes.

Silence

This is a global function which deletes all active sound sources of the [BGM](#) or [General](#) priorities. This function is available only for logical inputs and the ABT-DFMS fireman microphone buttons and may be activated even if the fireman microphone is not in the alarm mode. If the [Silence](#) mode is active (a red LED on the microphone at the [Silence](#) function button is on), then BGM and General matrices cannot be activated. Deactivation of the function unblocks priority matricing.

Skip Scenarios Delay

This is a global function and results in prompt execution of all scenarios for which the delay time countdown has started (purple LED blinking).

Stop Scenario

The function results in stopping execution of a scenario, as declared in the configurator. The scenario stop causes switching off all active matrices included in the scenario, whereas the status of the relay outputs which might have been a part of the scenario remains consistent with the programmed state at the moment of stopping the scenario.

Start/stop matricing

The function enables activation or deactivation, via one logical input or button on the zone/fireman microphone, of one or many matrices, as defined in the configurator. Each matrix can be assigned an individual activation mode – [start](#) / [stop](#) / [toggle](#).

Zone(s) off

The function acts on the principle of dynamic assignment, i.e. in order to activate the function, one needs to follow a predefined order. The first activity is to select a zone or many zones using the programmed button [Select Zone](#), then the [Zone\(s\) off](#) button is selected. Thus activated, the function causes irreversible disconnection of all active sound sources of [BGM](#), [General](#), [Service](#) priorities.

External Fault CIN

The [External fault CIN](#) can only be assigned to a system logical input. Having activated the logical input to which the function is assigned, in the fault window on the GUI, as well as in system logs, an entry will be displayed with the name of the logical input. Change the name of the logical output in order to identify the fault-reporting device in an unequivocal way.

Volume change

The volume change function controls only the levels of audio outputs in the miniVES system. The function is activated by dynamic assignment. There are two methods of volume change execution in the configurator:

1. **Change** – the level of signal at an audio output will be decreased or increased by the value declared in decibel in the **Volume** window compared to the level set in the audio output individual configuration window. Each successive activation of the function within the Change mode results in a decrease or increase by the value with respect to the level having been set.
2. **Set** – the level of the signal of an audio output will be set to the value declared in decibel in the **Volume** window.

If the control unit utilizes only matricing using common HVaudioBus, then the **Volume change** function is not active.

Additionally in the **Select zone selection mode** field you can choose between:

Selected zones – meaning that dynamic assignment is being applied. Choose the zones by pressing the dedicated zone selection button and then use the volume change function

Defined zones – meaning that the zones affected by the function are predefined. In this mode the volume control is activated immediately after pressing the assigned button with no need of selecting the zones. To predefine affected zones double-click the desired items in the **Available zones** field.

Volume(in dB):	0
Select change type:	Change
Select zone selection mode:	Defined zones
Defined zones:	Available zones:
1 Floor 1	1 Floor 2
2 Floor 10	2 Floor 3
	3 Floor 4
	4 Floor 6
	5 Floor 7
	6 floor 8
	7 Garage level 2
	8 Garage TOP 1
	9 Stairs A
	10 Stairs B

13.9.2 DMS-LCD Configuration

The DMS-LCD microphone has the same configuration window as the DMS microphone. The only exception being that, to set up the messages and zones visible on the LCD touch panel you should go to the [DMS-LCD configuration](#) tab on the left side of the screen menu bar .

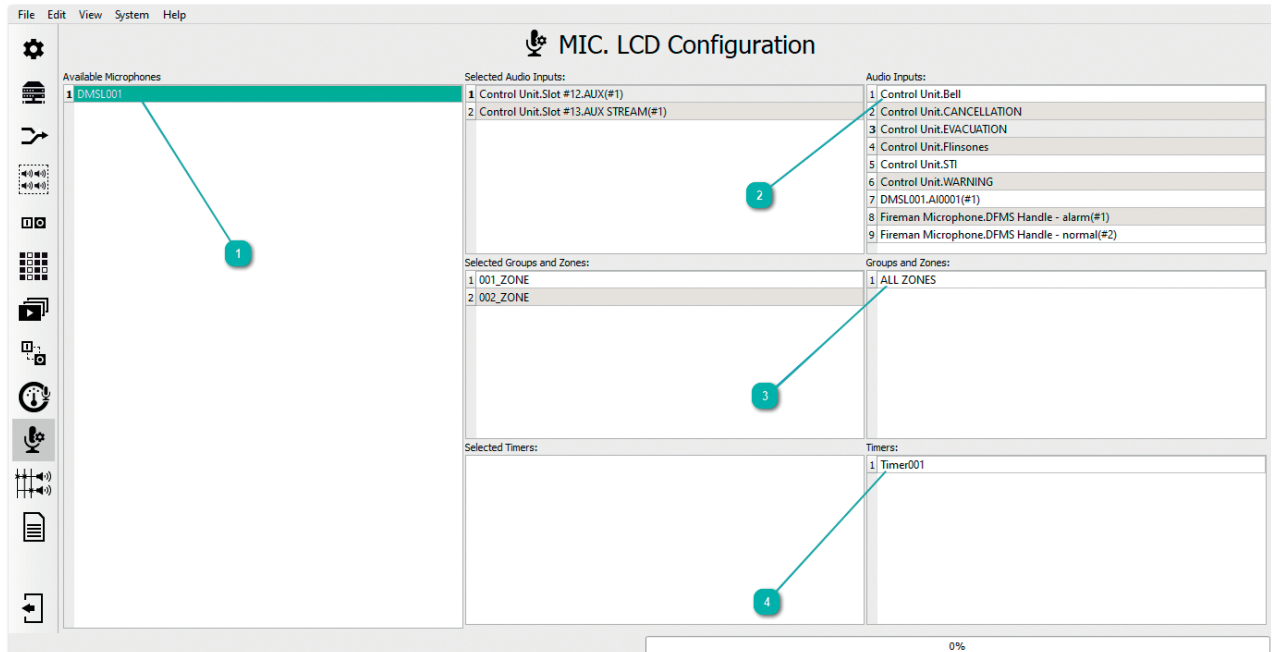

1 Available Microphones

A list of available DMS-LCD microphones in the system. Every microphone can have individually programmed access to audio inputs and zones.

2 Audio inputs

A list of defined audio sources / messages available in the MULTIVES system. A double-click on the chosen input source will transport it to the [Selected Audio Inputs](#) field and add it to the DMS-LCD microphone touch screen menu.

3 Groups and zones

A list of defined audio outputs / zones available in the MULTIVES system. A double-click on the chosen output transports it to the [Selected Groups and Zones](#) field and add it to the DMS-LCD microphone touch screen menu.

4 Timers

A list of defined timers available in the MULTIVES system. A double-click on the chosen output transports it to the [Selected Timers](#) field and add it to the DMS-LCD microphone touch screen menu.

13.9.3 NCS6 Configuration

Connection and configuration

The ABT-NSC6 module is a Noise Sensing Controller and is used to automatically adjust the volume of the signal in relation to the sound pressure level of the ambient noise in the desired area.

The ABT-NSC6 module connects to the rest of the system using an Ethernet cable as standard TIA / EIA-568-B and the LAN or LAN / POE port, its further configuration is carried out in the Selector software.



Drawing 84. ABT-NSC6 Noise Sensing Controller

Two types of noise sensing microphones are available, compatible with the ABT-NSC6 module:

- » ABT-NSM1
- » ABT-NSM2

NSC6 configuration panel allows to assign one or many Noise Sensing Microphones to one zone or group of zones. In this area output levels together with number of microphone thresholds can be also defined (from 1 to 10).

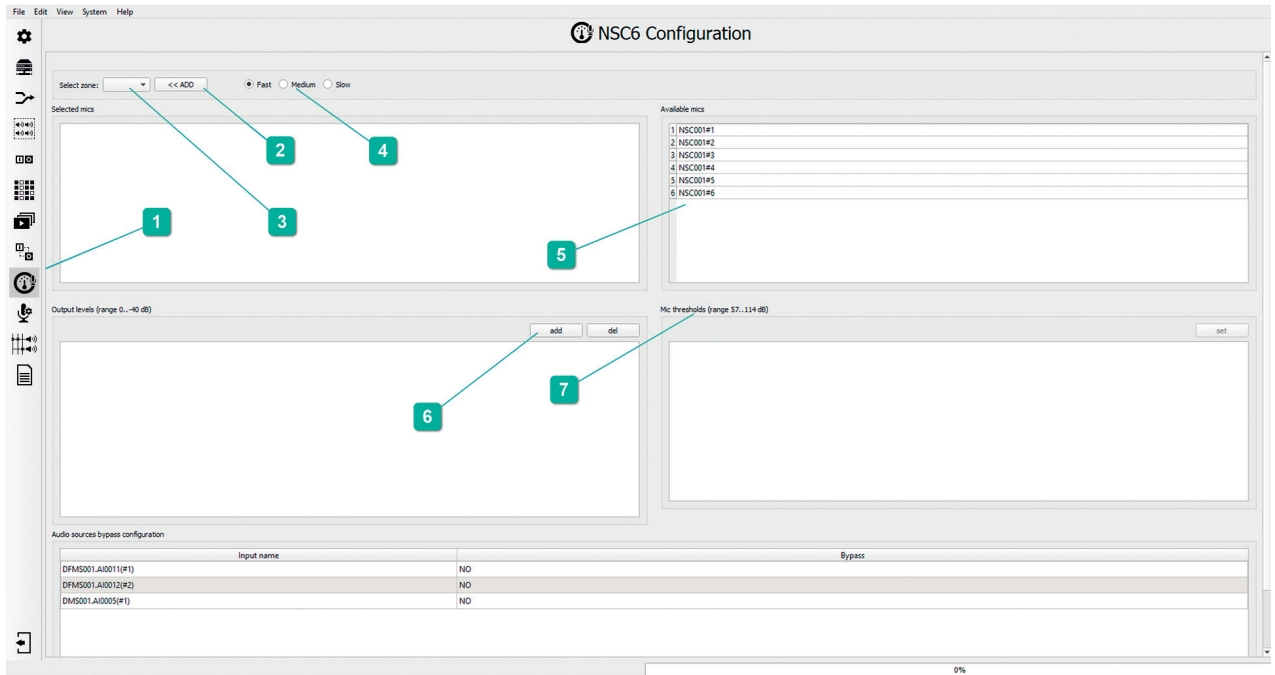

1 The **NSC6 Configuration** icon is used to open configuration window background microphone controller ABT-NSC6.

2

To start NSC6 configuration process assigning of NSC to desired zones has to be made. To do this **<<ADD** has to be pressed. Then, dedicated window with available zones will be displayed. To select zones, which will be controlled by NSC please double-click on **NO** in Selected column to switch it to **YES** value. After selection window can be closed with **x** sign or **Close** button.

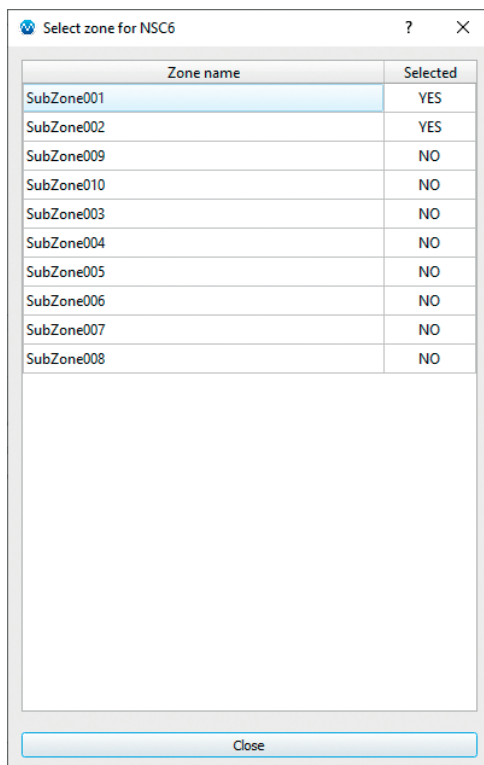

3 Select zone SubZone1 ▾

After zone selection process described above, next step is to select from drop-down list Zone or Group which detailed settings will be defined in next step.

- SubZone001
- SubZone002
- SubZone003
- SubZone004

4 Fast Medium Slow

Each volume change on zone or group can be defined with own reaction time for ambient sound pressure level change. Three modes are available: Fast, Medium, Slow. Each of those modes define reaction time for rising Edge (UP) and falling Edge (DOWN). Values in seconds are shown below:

	UP	DOWN
FAST	2	4
MEDIUM	5	10
SLOW	10	20

The selection is made for each selected zone separately.

5 Available mics

1	NSC001#2
2	NSC001#3
3	NSC001#4

It is needed to assign at least one NSC microphone input to zone, which will be controlled. In this possible to assign up to 6 NSC inputs to single zone – in this case triggering threshold limit by one of microphones will result in volume change on controlled zone.

To assign NSC microphone:

- > select zone from drop-down list
- > by double LMB click select in column Available mics desired inputs, that will be used for volume adjustments.

6 Output levels (range 0...-40 dB)

	Value	Buttons
1	0 dB	add del
2	-10 dB	

Next stage is to define number and

It is possible to define up to 10 levels. Changing number of levels is done by ADD and DEL buttons. Each of those levels can be adjusted by 1dB with up and down arrows.

-15 dB

Mic thresholds (range 57...114 dB)

	Value	Buttons
1	65 dB	set
2	58 dB	
3	57 dB	

Number of Thresholds is directly connected with number of Output levels parametrized in step before.
Number of Thresholds equals number of Output levels -1.

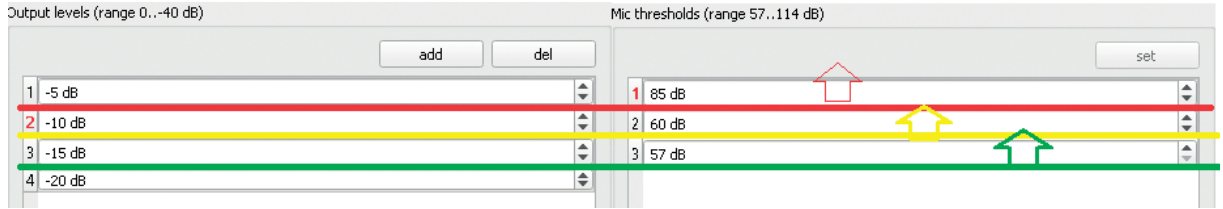

On above example principle of work of NSC is shown. If measured ambient sound pressure level is below 57dB (green line) then output volume will be attenuated by -20dB. When SPL will be between 58 and 60dB then output volume will be attenuated by -15dB. When SPL will be above 85dB then output volume will be attenuated by -5dB. Both Output Levels and Mic Thresholds can be individually defined.

NSC is active all time, when system is broadcasting messages or is in standby.

NOTICE: To measure the ambient noise level live, go to the [System Configuration](#) tab, in the topology view, double-click NSC6 module, enable **ON-LINE** mode, then read the sound pressure values that will be displayed on the right of the microphone input fields. Observe the maximum and minimum SPL received by NSC microphones and use these values as the maximum and minimum microphone thresholds.

- List of audio sources in which [Bypass](#) can be activated and volume control disabled for these sources. To do this, double-click the **NO** icon in [Bypass](#) column. Changing to the **YES** form confirms activation of bypass.

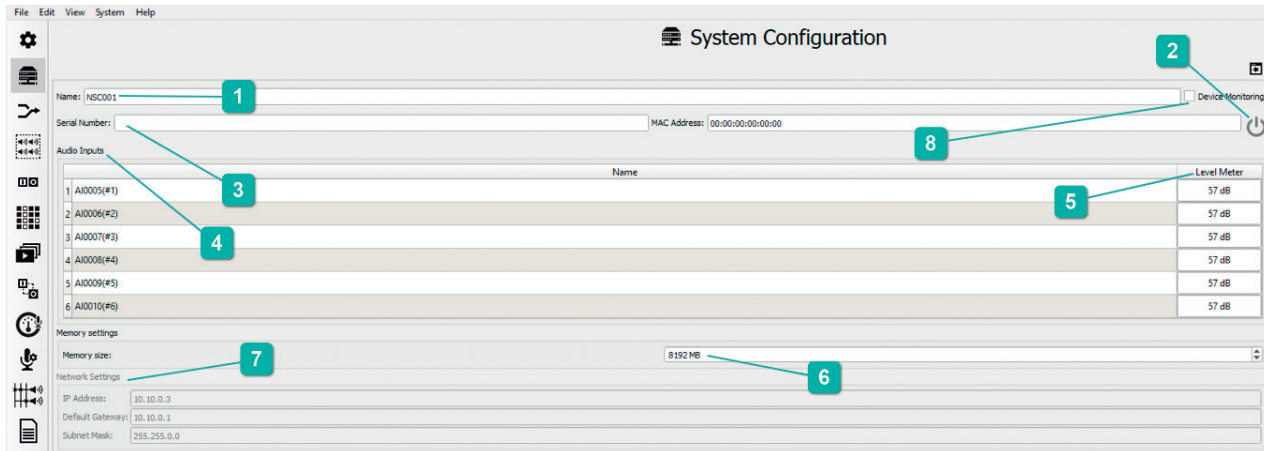

Audio sources bypass configuration	
Input name	
DFMS001.AI0005(#1)	YES

Further configuration is possible by double-clicking NSC6 module in system topology window.



1 Name: NSC001

The Name field allows you to give an individual name to each NSC6 module.

2 On-Line mode allows you to view SPL values in the **Level Meter** column. When the system has an updated configuration and is active, clicking the gray icon  will activate the on-line mode, which will be confirmed by a change icon color to green . When online mode is active, the measured sound pressure value is displayed.

3 Serial Number: MAC Address: 00:00:00:00:00:00

The field with serial number and mac address is completed automatically after reading the system topology.

4 Audio Inputs

1	AI0005(#1)
---	------------

Each NSC6 module has 6 inputs for ABT-NSM background microphones. The generic name of the input, e.g. **AI0005**, can be changed freely and symbol # with the number indicates number of physical input on PCB module .

5 Level Meter

57 dB

The value shown in the **Level Meter** column is measured value if online mode is active. This value is useful when setting thresholds for attenuation.

6 8192 MB

This field shows the physical capacity of the memory card.

7 Network Settings

IP Address:	10.10.0.3
Default Gateway:	10.10.0.1
Subnet Mask:	255.255.0.0

These fields present network parameters such as the IP address that will be assigned to the NCS6 controller. This is for informational purposes only and these values should not be changed manually.

8 Device Monitoring

Checking this box means that the NSC-6 module connection will be supervised.

13.10 The Amplifier Output Manager Tab

The Amplifier output manager tab verifies and presents the possibility or the inability to work in the configuration prepared by the user. This is very important configuration part for miniVES and midiVES systems where for defined speaker line loads processor can distribute the power across available amplifiers avoiding at the same time uncontrolled overload of resources. The algorithm consists in calculating the power loads of the loudspeaker lines included in the active audio matrices and dynamically assigning them to the available resources of the amplifiers. Depending on the cards available in the system for the miniVES systems based on the xCtrlLine-2 and xCtrlLine-4 cards, the installer must manually enter the power values on each speaker line. For the midiVES systems based on new xCtrlLine-44 cards, we also have the option of entering the data manually, however, after uploading the configuration to system, we can automatically measure the power of the connected loudspeaker lines. The measuring sequence is using a 1 kHz signal.

The developed algorithm, apart from the distribution of audio signals to amplifiers, allows for a safe and controlled use mechanism of amplifiers overload due to the use of limiters on the audio outputs. This allows for a guarantee of broadcasting at least 1 message for miniVES and 2 messages for the midiVES system in the event of failure of one of the amplifiers.

The screenshot shows the 'Amplifier Output Manager' window in 'Selector - active mode (Project1.yml*)'. The interface includes a menu bar (File, Edit, View, System, Debug, Help) and a toolbar with various icons. The main area displays a table with the following columns: Name of element, Select all zones to set power, Assigned Power Load [W], Replace Power, Power [W], Impedance [ohm], Total Power, Allocated Buses, Available Power [W], and Status.

Name of element	Select all zones to set power	Assigned Power Load [W]	Replace Power	Power [W]	Impedance [ohm]	Total Power	Allocated Buses	Available Power [W]	Status
System (Global Settings)									
	<input type="checkbox"/>	30 [W]	Set Speaker Zones Power	10 %	Read				
CU001	<input type="checkbox"/>	CU BUS Total Power: 0 [W]		Read		BUS Total Power: 1500	3	500 [W]	
CU001.Slot #1 (xCtrlLine-44)		Total Card Power: 501 [W]	Replace	Read					
Line A (SubZone001)		200	Replace	0	Out of range				
Line B (SubZone002)		200	Replace	0	Out of range				
Line C (SubZone003)		96	Replace	0	Out of range				
Line D (SubZone004)		5	Replace	-	-				
CU001.Slot #2 (xCtrlLine-44)		Total Card Power: 20 [W]	Replace	Read					
Line A (SubZone005)		5	Replace	0	Out of range				
Line B (SubZone006)		5	Replace	0	Out of range				
Line C (SubZone007)		5	Replace	0	Out of range				
Line D (SubZone008)		5	Replace	0	Out of range				
CU001.Slot #3 (xCtrlLine-44)		Total Card Power: 20 [W]	Replace	Read					
Line A (SubZone009)		5	Replace	0	Out of range				
Line B (SubZone010)		5	Replace	0	Out of range				
Line C (SubZone011)		5	Replace	0	Out of range				
Line D (SubZone012)		5	Replace	0	Out of range				
CU001.Slot #4 (xCtrlLine-44)		Total Card Power: 94 [W]	Replace	Read					
Line A (SubZone013)		79	Replace	88	114				
Line B (SubZone014)		5	Replace	0	Out of range				
Line C (SubZone015)		5	Replace	0	Out of range				
Line D (SubZone016)		5	Replace	0	Out of range				

Selector - active mode (test_overload_1ymf)

File Edit View System Help

Amplifier Output Manager

Name of element	Select all zones to set power	Assigned Power Load [W]	Replace Power	Power [W]	Impedance [ohm]	Total Power	Allocated Buses	Available Power [W]	Status
System (Global Settings)									
	<input type="checkbox"/>	30 [W]	Set Speaker Zones Power	100 %	Read				
JK3	<input type="checkbox"/>	CU BUS Total Power: 0 [W]	←	Read		BUS Total Power: N/A	1	160 [W]	This unit uses HV individual Amplifiers.
JK4	<input type="checkbox"/>	CU BUS Total Power: 0 [W]	←	Read		BUS Total Power: N/A	0	160 [W]	This unit uses HV individual Amplifiers.
JK1	<input type="checkbox"/>	CU BUS Total Power: 0 [W]	←	Read		BUS Total Power: N/A	1	160 [W]	This unit uses HV individual Amplifiers.
JK7	<input type="checkbox"/>	CU BUS Total Power: 460 [W]	←	Read		BUS Total Power: 460	3	160 [W]	
JK8	<input type="checkbox"/>	CU BUS Total Power: 1500 [W]	←	Read		BUS Total Power: 1500	3	500 [W]	
JK3 Slot #1 (CtrlLine=44)									
Total Card Power: 375 [W]									
Line A (AO_KJ3_1A)		200	Replace	491	20				WARNING - The measurement power exceeds the maximum line power
Line B (AO_KJ3_1B)		110	Replace	Out of range	3970				WARNING - Measured power out of range. Value < 5 W
Line C (AO_KJ3_1C)		50	Replace	Out of range	8500				WARNING - Measured power out of range. Value < 5 W
Line D (AO_KJ3_1D)		15	Replace	Out of range	Out of range				WARNING - Measured power out of range. Value < 5 W
JK3 Slot #2 (CtrlLine=44)									
Total Card Power: 375 [W]									
Line A (AO_KJ3_2A)		200	Replace	-	-				WARNING - Download of the data was not possible.
Line B (AO_KJ3_2B)		110	Replace	-	-				WARNING - Download of the data was not possible.
Line C (AO_KJ3_2C)		50	Replace	-	-				WARNING - Download of the data was not possible.
Line D (AO_KJ3_2D)		15	Replace	-	-				WARNING - Download of the data was not possible.
JK3 Slot #3 (CtrlLine=44)									
Total Card Power: 375 [W]									
Line A (AO_KJ3_3A)		200	Replace	Out of range	Out of range				WARNING - Measured power out of range. Value < 5 W
Line B (AO_KJ3_3B)		110	Replace	Out of range	Out of range				WARNING - Measured power out of range. Value < 5 W
Line C (AO_KJ3_3C)		50	Replace	10	954				
Line D (AO_KJ3_3D)		15	Replace	5	1863				
JK3 Slot #4 (CtrlLine=44)									
Total Card Power: 375 [W]									
Line A (AO_KJ3_4A)		200	Replace	Out of range	Out of range				WARNING - Measured power out of range. Value < 5 W
Line B (AO_KJ3_4B)		110	Replace	Out of range	Out of range				WARNING - Measured power out of range. Value < 5 W
Line C (AO_KJ3_4C)		50	Replace	Out of range	Out of range				WARNING - Measured power out of range. Value < 5 W
Line D (AO_KJ3_4D)		15	Replace	Out of range	Out of range				WARNING - Measured power out of range. Value < 5 W
JK2	<input type="checkbox"/>	CU BUS Total Power: 620 [W]	←	Read		BUS Total Power: 640	4	160 [W]	
JK6	<input type="checkbox"/>	CU BUS Total Power: 20 [W]	←	Read		BUS Total Power: 320	2	160 [W]	
JK5	<input type="checkbox"/>	CU BUS Total Power: 40 [W]	←	Read		BUS Total Power: 640	2	320 [W]	

50 Select all zones to set power:

The column allows globally determine the range of assigned values for all speaker lines available in a system consisting of many miniVES _ midiVES units („System Global Settings”) or for a selected ones.

2 Assigned power load:

The **Assigned Power Load** column contains two Spinbox items on one line to set the power globally and a button to assign this power to the line of control cards. At the moment when the user sets a value and clicks on the button, this value will be copied to the control cards that have the box checked in the Select all zones to set power column.

3 Groups and zones:

- » Buttons for data replacement – Possible options replace by single speaker line or entire control card.
- » Black arrow representing the direction of data flow from measured to declared.

The column allows you to assign the values of the measured speaker lines and replace these values with those previously declared by the user in the **Assigned Power Load** column. If the measured value will exceed the percentage (D section) of the defined value, the system will mark the given element in red and warning in **Status** column will display “The tolerance between declared speaker line load and measured are exceeded”. The **tolerance range** or **assigned power load** should then be increased.

50 Power column:

The column Power includes a button with the text "Read" used to read the power on all control cards available in the system.

Support for power measurement only for xCtrl-line-44 card.

After clicking on any of the buttons marked as Read, a popup window will appear with information confirming the willingness to take measurements. The texts to appear in this window are presented below:

- » For the system – Global settings (section 1)
 - › Do you want to measure power's for this system.
 - › This operation may take up to 1 minute.
- » For the selected unit (section 2)
 - › Do you want to measure power's for this unit.
 - › This operation may take up to 1 minute.
- » For the selected control card xCtrl-line-44 (section 3)
 - › Do you want to measure power's for this card.
 - › This operation may take up to 1 minute.

In this popup buttons "Yes" and "No" appear. After clicking on the button confirming the operation, a window appears with a progress bar and text "Downloading data ..." representing the measurement process.

A The measurement procedure cannot be performed on a system without configuration (factory default), because it is not possible to send queries to the unit. Inquiries are sent with ID numbers of a given card. If there is no configuration, there are no device identifiers.

A

B After reading the measurements, it is necessary to display them in the Power column - Section 5 and Impedance column - Section 4. The following are the cases that may occur:

- » If the read value is lower than 5 [W] in the line in which this situation occurred, the Replace button is grayed out, which will block the possibility of transferring the read value to the configuration. "Out of range" will appear in the text field and the information that the measurement range is exceeded in the Status column (section 6).
- C** » If the value read in the "Power" column is higher than 200 W, the possibility of transferring the value to the configuration is blocked by grayed out the "Replace" button with information in the status field about the line overload.
- » If the read data is higher than 1670 [W], proceed as for the value lower than 5 [W].
- » If the measurement is in the range 5 to 200 [W] the power and impedance values will be displayed and tolerance range will be checked:
 - › The default tolerance setting is 10%. After reading the power of individual loudspeaker lines, it is verified whether **D** the read powers are within the tolerance range compare to defined values by the user. Tolerance range min 5 max 100%.
- » If there is any problem in the Status column, the displayed text will be red in the line where the error occurred. In addition, the red color should be set on the card line and the unit in the Name of elements column so that the user knows that there is a problem in the given unit.

Error handling

The types of errors and their codes are listed below:

- "WARNING - Speaker line Ground fault"
- "WARNING - Connection timeout" - in case of reaching the timeout while reading the data.
- "WARNING - Speaker line shorted" - for a short circuit on the line.
- "WARNING - Unable to measure power" - for no measurement conditions.
- "WARNING - Measured power out of range. Value < 5 W" - for exceeding the measuring range below 5 W.

- **E** “WARNING - Measured power out of range. Value > 1670 W” - for exceeding the measuring range above 1670 W.
- “WARNING - Measured impedance out of range. Value > 10 000” - for exceeding the measuring range above 10,000 Ohm.
- “WARNING - Measured impedance out of range. Value < 6 Ohm” - for exceeding the measuring range below 6 Ohm.
- “WARNING - The measurement power exceeds the maximum line power” - for the maximum line power.
- “Out of range” - In the Impedance column when calculating a value greater than 10,000 ohms.

The values from Assigned Power Load column are stored in [Reports](#) section – [Line control Report](#); Reports can be printed as a separate pdf files.

13.11 Reports

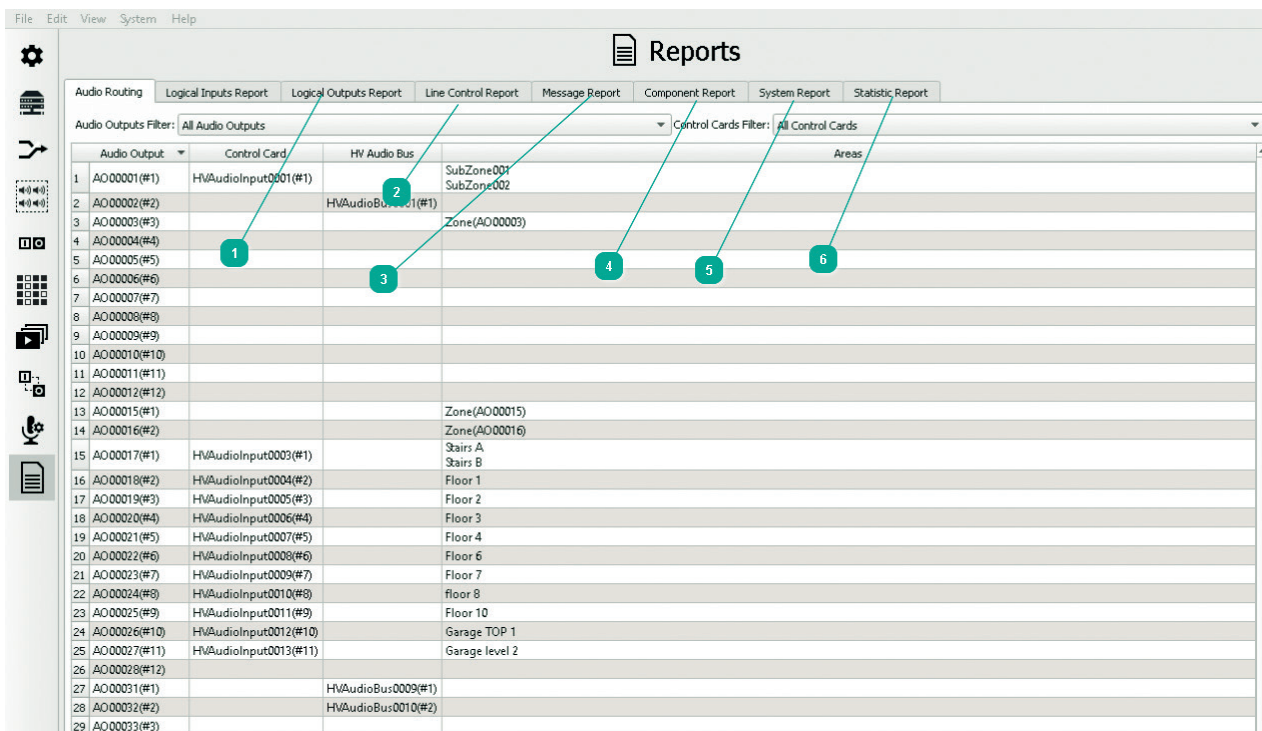

Audio Output	Control Card	HV Audio Bus	Areas
1 AO00001(#1)	HVAudioInput0001(#1)		SubZone001 SubZone002
2 AO00002(#2)		HVAudioBus0001(#1)	
3 AO00003(#3)			Zone(AO00003)
4 AO00004(#4)			
5 AO00005(#5)			
6 AO00006(#6)			
7 AO00007(#7)			
8 AO00008(#8)			
9 AO00009(#9)			
10 AO00010(#10)			
11 AO00011(#11)			
12 AO00012(#12)			
13 AO00015(#1)			Zone(AO00015)
14 AO00016(#2)			Zone(AO00016)
15 AO00017(#1)	HVAudioInput0003(#1)		Stairs A Stairs B
16 AO00018(#2)	HVAudioInput0004(#2)		Floor 1
17 AO00019(#3)	HVAudioInput0005(#3)		Floor 2
18 AO00020(#4)	HVAudioInput0006(#4)		Floor 3
19 AO00021(#5)	HVAudioInput0007(#5)		Floor 4
20 AO00022(#6)	HVAudioInput0008(#6)		Floor 6
21 AO00023(#7)	HVAudioInput0009(#7)		Floor 7
22 AO00024(#8)	HVAudioInput0010(#8)		floor 8
23 AO00025(#9)	HVAudioInput0011(#9)		Floor 10
24 AO00026(#10)	HVAudioInput0012(#10)		Garage TOP 1
25 AO00027(#11)	HVAudioInput0013(#11)		Garage level 2
26 AO00028(#12)			
27 AO00031(#1)		HVAudioBus0003(#1)	
28 AO00032(#2)		HVAudioBus0010(#2)	
29 AO00033(#3)			

In the [Reports](#) tab there is a table containing all of the most important information on the system. The [Audio Routing](#) tab represents the place of assignment of all audio outputs. In addition, it shows which speaker zones are handled by the control card and which audio output supplies them. Via the [Go to Definition](#) function available for the [Audio Output](#), [Control Cards](#) and [HV Audio Bus](#) columns in the [Audio Routing](#), it is possible to make changes in the system in a simple and easy way.

- 1 [Logical Output Report](#) – this is a list of all logical inputs with information about the current operating mode NO/NC.
- 2 [Line Control Report](#) – the list of measured impedance references saved in the system.
- 3 [Message Report](#) – summary of all reference impedance values saved in the system.
- 4 [Component Report](#) – a quantitative list of all cards, zone/fireman microphones, touch screens included in the miniVES system. In addition, there is a summary of available audio inputs and outputs, logical inputs and individual component software versions.

- 5 **System Reports** – a list of all failures and software events that occurred during normal operation. The system is capable of storing and reading over 100 thousand single events. An advanced filtering method, using date, unit and system state, makes it much easier to identify a problem which occurred in the system.
- 6 **Statistic Report** – enables displaying of all available service data from diagnostic modules located on SFP slots. This is a unique function which shortens the time needed to verify the quality of the optical fibre and eliminate communications faults by displaying, among others, the strength of the signal transmitted and received, the number of lost packages or the internal temperature of the SFP insert.

13.12 Basic steps required to program the system

In order to program a basic miniVES configuration and make the system fully operational, follow these steps:

1. Logical output OUT1 – assign the **Error** event and change it's generic name to **Fault**
2. Logical output OUT2 – assign the **Alarm** mode event and change the generic name to **Alarm ACK**
3. Add the alarm (evacuation) message and change it's generic name to **Evacuation**. Set it's priority to 10
4. Change the generic name of the Audio input no.3 to **Local Audio IN**
5. Change the generic name of the built in firemans microphone (audio input no.1) to **Fire Mic minives XXXX**
6. Change the generic name of the built in microphone in general mode (audio input no.2) to **Local Mic**
7. On the line control cards, change the generic names:
 - › **miniVES2001**
Zone 1 – lines A+B, Zone 2 – lines C+D, control method: impedance
 - › **miniVES4001**
card in slot 1: Zone 1 – lines A+B, Zone 2 – lines C+D, control method: impedance
card in slot 2: Zone 3 – lines A+B, Zone 4 – lines C+D, control method: impedance
 - › **miniVES4002**
card in slot 1: Zone 1 – lines A+B, Zone 2 – lines C+D, control method: impedance
card in slot 2: Zone 3 – lines A+B, Zone 4 – lines C+D, control method: impedance
card in slot 3: Zone 5 – lines A+B, Zone 6 – lines C+D, control method: impedance
card in slot 4: Zone 7 – lines A+B, Zone 8 – lines C+D, control method: impedance
8. Create a **Zone group – All Zones** and add all of the available zones depending on the miniVES type
9. Create a new matrix and name it **Evacuation** – add the Evacuation message from the available **Audio inputs** field and the **All zones zone group**
10. Logical input INPUT1, contact mode – assign the following events:
 - › **Active** – Alarm mode (start) and **General** – add the **Evacuation** matrix (start)
 - › **Inactive** – Alarm mode (stop)

Change the generic name of the input to **Evac activation**.
11. In the **Events configuration** tab:
 - › Assign the built in **Emergency** buton (1) to Alarm mode event (start) and the select zone event choosing **All zones**

- › Key 2 – change the generic name to Evacuation Start and assign the start/stop matricing event (toggle)
- › Key 3 – change the generic name to LED test and assign the led test event
- › Key 4 – change the generic name to Stop Evacuation and assign the Alarm mode (stop)

13.13 Glossary

Function activating modes

Start – selected button or logical input only activates a function programmed in the system.

Stop – selected button or logical input only deactivates a function programmed in the system.

Toggle – selected button or logical input triggers, a change of state to the opposite upon every next activation, acting like an on/off switch. In case of logical inputs, a necessary condition for reactivation of the function in the toggle mode is returning to the input's idle state.

Dynamic assignment

In order to trigger a function whose activation relies on dynamic assignment, follow the predefined order. The first activity is selection of a zone or multiple zones by means of the programmed [Select Zone](#) button, in this way we highlight which zone(s) the function is to affect, then select the button assigned to the function which we want to execute.

Audio inputs – these are all analogue inputs available in the miniVES system to which external sound sources can be connected to.

Audio outputs – these are all outputs available in the miniVES system, whose parameters are compatible with the audio inputs of the amplifier modules. Control units are equipped with audio outputs, e.g. ABT-CU-11 has 12 audio outputs, as well as zone microphones which are equipped with 4 outputs.

Audio source – in the miniVES system, an audio source is both a recorded message, regardless of its priority, a linear audio input on a unit and a zone microphone, as well as the microphone itself.

Individual HV Audio In – this is an input found on each xCtrlLine-4 /xCtrlLine-2 control card which is used to connect an amplifier modules 100 V output to the card. In the miniVES system it is used exclusively in the 4002 series units to drive two of the four xCtrlLine-2 cards.

System states – there are 4 system states available in the configurator: [Alarm mode](#), [Error](#), [Blocking](#), [Backup Power](#) due to which any function can be activated or an element available in the system can be controlled.

Go to Definition is a quick access function which is activated by clicking the left mouse button while moving over onto the name of any element in the system. This function results in a transition to the card, microphone, device microphone extension detailed editing window.

Configurator

Software supplied with the miniVES system with the help of which it is possible to manage and program system devices.

FIFO (First IN, First OUT) – in case of conflict of two audio sources of the same priority, where Source 1 is already transmitting to the zone and Source 2 is also to begin transmitting to the same zone, Source No 1 will not be removed in order to make the zone available for Source No 2 until Source No 1 (matrix) has concluded transmission.

LIFO (Last IN, First OUT) – in case of conflict of two audio sources of the same priority, where Source 1 is already transmitting to the zone and Source 2 is also to begin transmitting to the same zone, Source No 1 will be disconnected from the zone and Source No 2 will transmit to the zone.

LUA – scripting language used to extend the functionality of the miniVES system. This language is implemented as the C language library, written according to ANSI C, providing: simplicity, performance and code transferability.

Signalization priority

	PRIORYTET (0 – highest)
Block zone	0
Zone failure <ul style="list-style-type: none"> > closing /shorting /opening > no EOL > impedance error > switching into LOOP 	1
Zone failure confirmed	1
EVACUATION MESSAGE playback	2
WARNING MESSAGE playback	2
Spoken message from fireman microphone	2
Spoken message from zone or BGM microphone	2
Volume change	3
Audio Monitor	4

13.14 FAQ

1. No visible miniVES server in the System Connection window

In order to either upload a configuration onto a system, go into the on-line mode or download system reports, the configurator must be connected to a server visible in the system connection window. The first thing one must do in this situation, is to make sure that the IP configuration of the computer running the software is not set to a static IP adress. To do so, check the Local area connection properties in the Internet protocol version 4 (TCP/IPv4) tab, the „obtain an IP adress automatically” option should be checked. The next step should be deactivating the Windows internal firewall. Go to the Control Panel -> System and Security -> Windows Firewall -> Turn Windows Firewall on or off apply this to both the private and public network. If the server is still not visible in the connection window, please check the computer for running antivirus software such as Eset, Avast, AVG, if the computer is running this software, disable it for the time of system configuration. It is recommended to add the miniVES connection to a list of safe connections in the OS.

2. Configuration of a running miniVES system impossible to download

In order to correctly download the configuration, follow these steps:

1. Start the configurator
2. Select [Create a new configuration](#) – **IMPORTANT!**
3. Connect to the system by clicking [System](#) -> [Connection Settings](#) and the [Connect](#) button
4. Then in the same window choose the [Download current configuration](#) option

3. A downloaded running miniVES system configuration cannot be opened

The downloaded file from the system, config.afz can be found in the tab Documents → Selector → Workspaces_x.x.x (where x indicates the version of the software) → downloadedConfiguration. To run the downloaded file from the system (*.afz) you need to:

1. Select in the configuration software: [File](#) → [Import working area](#)
2. As a standard, the configuration software creates files and saves them under: C:\Users\Documents\Selector\Workspaces_x.x.x \downloadedConfiguration. If you have chosen a different access path, please choose from it the appropriate file with the .afz extension and then select option [Open](#).
3. When you select [Open](#) option, the system asks for the indication of a new folder in order to copy the imported content from the system configuration. You should create a new folder, give it any name, select it and choose [Select Folder](#) option. **Please note that it is a very important step!**
4. Select [YES](#) option in the window if you want to open the imported configuration
5. The configuration will be loaded – in the [System connection](#) window with the [Connect](#) option, the [Same configuration status](#) should be shown. If [Different configuration](#) status is shown in the window, please select [File](#) → [Load](#) → the newly created folder while importing the file with the .afz extension. There are configuration.afz files available in the location they were created when configuring the system. You have to load those files and then check the status until it shows the [Same configuration status](#).

4. DFMS, DMS or DMS-LCD microphone reboots when connected to the system

If you additionally connect a microphone to a properly functioning system, and it resets after connection this means that the microphone does already have a preloaded configuration in it's internal memory which is different from the configuration of the system. In this situation the factory (default) settings should be restored to the microphone and then the microphone should be reconnected.

5. The configuration software suspends while trying to compare the topology of the configuration created in offline mode

If the system cannot properly detect the devices available on the miniVES network and prevents assigning MAC addresses to the configuration items created in offline mode it means that the list of devices in the Working area is different from what is visible in the system. The solution to this, is to create a new project, which does not include any devices in the workspace and then select the [Recreate topology](#) option ([System](#) → [Connection Settings](#)). In this way you get to know the correct arrangement of the system devices in the workspace.

The arrangement of devices in the workspace should be restored to it's original configuration created in offline mode and then option [Recreate topology](#) → [Compare](#) should be reselected. Followed by a table appearing with all elements available in the system. To fill in the missing MAC addresses and serial numbers, use the FIX button.

6. The system does not respond to command [Restore to Factory Defaults](#)

Each project possess its own unique [Factory Defaults](#) signature, which is available in the window: [Basic Configuration](#) → [Factory Defaults](#). Every time you call the Default settings, the system checks the validity of the system signature with the one located in the configurator. Lack of compatibility will cause the command disregard.

7. How should I transfer a configuration that can be opened on another computer?

Full configuration means the device settings, source audio files, and summary of matrix, scenarios, zones etc. after conversion to pcm. It is written via [Export workspace](#) function in the [File](#) tab.

13.15 Appendix

1. AutoStandby mode

The purpose of the operation in **Standby** mode is:

- » limiting the power consumption from the battery while the primary AC 230 V power is lost;
- » reduction of heat generated by the amplifier modules while working on the primary power source at any preset time, if the system does not have any active matrices it goes into standby/idle mode.

Principle of Standby operation

Standby mode is activated automatically and every time when the following conditions are met simultaneously:

- » there has been a loss of primary power supply (230 V) and the system switched to battery power
- or
- » system has no active audio matrices and operates in Normal mode (no Alarm).

While working in active **Standby** mode the miniVES system periodically changes its operating states to the following sample states:

- » *active_state*
- » *suspended_state*

Duty cycle of the above conditions is as follows:

- » *suspended_state* – 85 seconds
- » *active_state* – 5 seconds

Central processing unit actions in **Standby** mode:

- » Periodically sends signals to the amplifiers indicating the current mode and operating state to enter amplifiers into power saving mode.
- » Periodically sends signals to all the control cards (xCtrl-2, xCtrl-4) informing cards about the current state of work (*active_state* / *suspended_state*) to force a power saving state to control cards (or exit from this state).
- » Each time while sending a command to change the state of the control card – it verifies whether the card has changed its state and if it properly reacts to read state.
- » Switching control and error reporting is done automatically after sending commands to change the status on *active_state* and confirmation from the card it has exited this mode.

Amplifier module actions in **Standby** mode:

- » During operation in the *suspended_state* amplifier modules enter a reduced power mode (amplifiers stop working and do not consume energy or consume a minimum value of it).
- » During operation in the *active_state* amplifier modules that entered a reduced power mode return to normal operation.

Standby mode is called using the **Standby** function.

- » That function can be activated by using:
 - › timers (it can be called in a cyclic manner at any preset time);
 - › any logic inputs;
 - › programmable “Key” push buttons;
 - › automatic run in the absence of active matrices defined by the user time [min] **AutoStandby**.
- » This function can be activated under the following conditions:
 - › system is not in alarm mode;
 - › there are no active audio matrices with **Emergency/Service** priority;
 - › system is powered from the primary source 230 VAC (while switching to emergency battery power it happens automatically if the system is not in alarm mode and there are no active **Emergency/Service** matrices).

AutoStandby – the function is activated/deactivated by the user on the level of the configuring software in the form of a checkbox. The function is activated in the absence of active audio matrices of **Emergency/Service** priorities after the time defined in the Configurator has passed.

The time is determined in minutes / The time interval [15 ... 300 minutes]

Default state – checkbox enclosed, active function

Default activation time: 60 minutes

[AutoStandby](#) function is available in the [Basic Configuration](#):

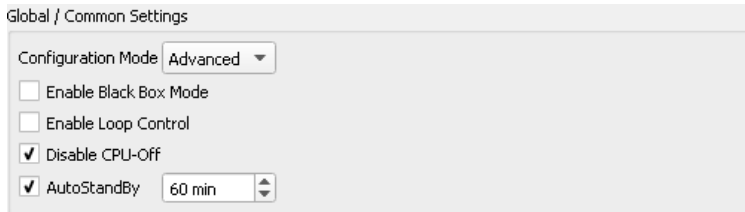

Each attempt of audio broadcasting while **Standby** is active causes:

- » exit from **Standby** to the **Normal** mode (when operating on the primary power source), regardless on the priority of a message;
- » exit from **Standby** mode to the **BattMode** (when there is lack of primary power supply) only when messages will have **Service/Emergency** priority.

The maximum duration of the activation process of exit from **Standby** mode to broadcasting message is shorter than 500 ms.

Because the function has been implemented in Phase 1 of miniVES development and its activation is dynamic ([Zone selection](#) then pressing [Power Save](#) button) there is need to change the way of its implementation from the dynamic to static (PA zones strictly defined in the configurator are to be deactivated / activated by friendly [Power Save](#) features).

Diagram of transition **Normal** mode – **Battery** mode – **Standby** mode is shown below:

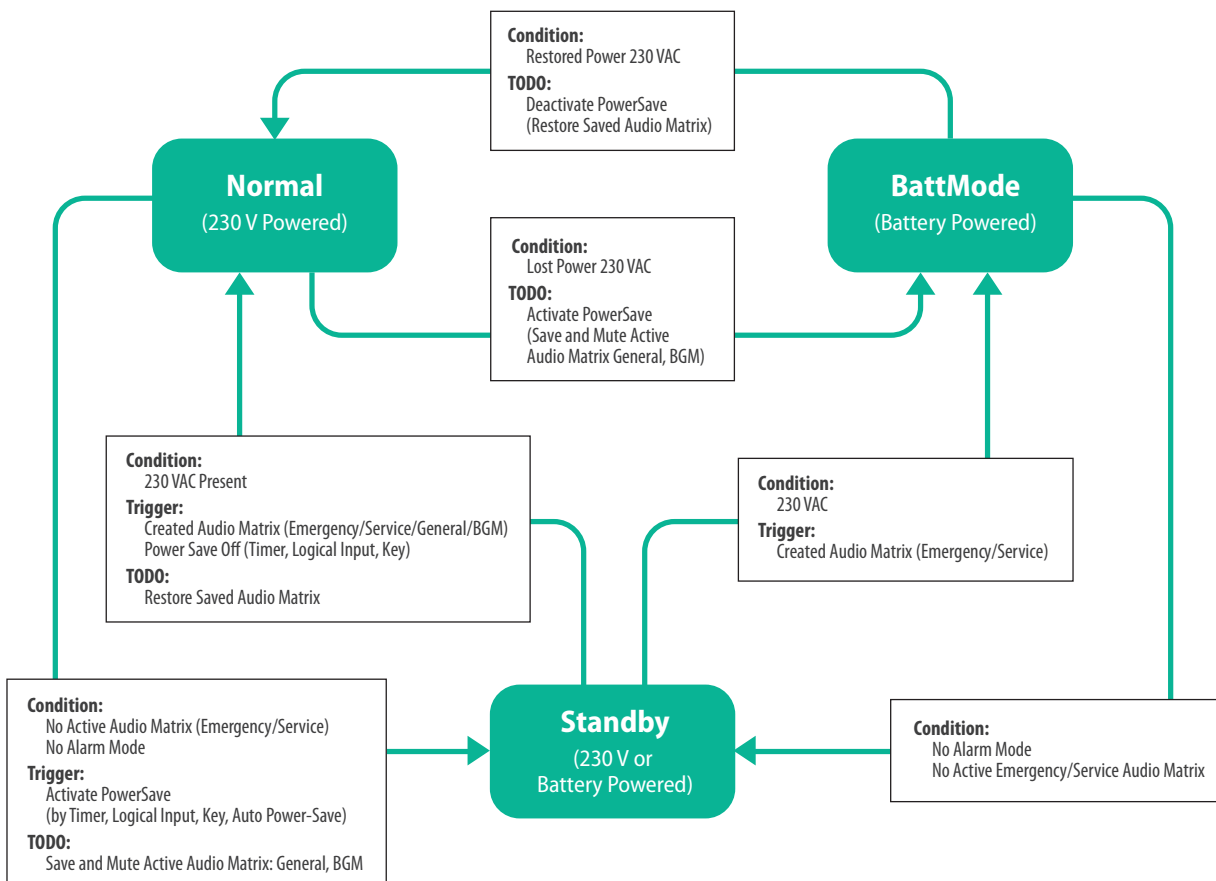

2. The list of faults reported by the system

E: Error – fault description visible on GUI of the control unit

W: Warning – access to this type of the information via Selector software – [System Report](#) only

I: Info – access to this type of the information via Selector software – [System Report](#) only

"E0002" – "Function backplane power failure" – no 12 V in the functional part
 "E0001" – "Function backplane power failure" – no 5 V in the functional part
 "E0003" – "Function backplane power failure" – no -12 V in the functional part
 "E0011" – "Control backplane power failure" – no 5 V control part
 "E0012" – "Control backplane power failure" – no 12 V control part
 "E0013" – "Control backplane power failure" – no -12 V control part
 "E0023" – "Power control system failure" – damage control system functional part
 "E0022" – "Power control system failure" – damage control system control part
 "E0101" – "Device do not respond"
 "E0102" – "Logical input open"
 "E0103" – "Logical input short"
 "E0104" – "Speaker line ground fault"
 "E0105" – "Speaker line short"
 "E0106" – "Files integrity error"
 "E0107" – "Speaker line impedance error"
 "E0108" – "Speaker line open"
 "E0109" – "EOL error"
 "E0110" – "Interruption of the audio path"
 "E0111" – "Battery failure"
 "E0112" – "Backup power / PSM missing"
 "E0113" – "230V AC power failure"
 "E0114" – "Amplifier overheat"
 "E0115" – "Fuse failure"
 "E0116" – "Power system manager failure"
 "E0117" – "48 V DC error"
 "E0118" – "No communication with ABT-ISLE"
 "E0119" – "Loop link error"
 "E0200" – "ABT-DFMS missing"
 "E0201" – "Evacuation button error"
 "E0202" – "Backup audio path interruption"
 "E0203" – "CPLD verification error"
 "E0204" – "Interruption of the audio path in ABT-DFMS capsule"
 "E0205" – "Internal hardware error"
 "E0206" – "Error triggered from logical input"
 "E0207" – "Integrity state error"
 "E0208" – "Test generator failure"
 "E0209" – "No conditions for measurement"
 "W0001" – "Function backplane power overload" – over current power supply 5 V functional part
 "W0002" – "Function backplane power overload" – over current power supply 12 V functional part
 "W0003" – "Function backplane power overload" – over current power supply -12 V functional part
 "W0011" – "Control backplane power overload" – over current power supply 5 V control part
 "W0012" – "Control backplane power overload" – over current power supply 12 V control part
 "W0013" – "Control backplane power overload" – over current power supply -12 V control part
 "W0021" – "Power supply overheat" – power supply overheat functional part
 "W0022" – "Power supply overheat" – power supply overheat control part
 "W0031" – "System operates on battery power"
 "W0101" – "Standby mode activation"
 "W0102" – "Standby mode deactivation"
 "W0103" – "Device Initialization error, dev=%0x"
 "I0101" – "Alarm mode activation"
 "I0102" – "Alarm mode deactivation"

"I0103" – "Event activation %xx"
 "I0104" – "Event deactivation %x"
 "I0105" – "Matrix activation %x"
 "I0106" – "Matrix deactivation %x"
 "I0107" – "Failure Accept"
 "I0108" – "Failure Delete"
 "I0109" – "Device start, dev=%x"
 "I0110" – "Connection state 0x%x->0x%x: %d"
 "I0111" – "Logical input 0x%x state changed %d"
 "I0112" – "Logical output (Relay) 0x%x state changed to the value %d"
 "I0119" – "Backup link activation"

An internal hardware error (E0205) is reported by the module when it diagnoses that one of its components is not working properly. Usually it concerns communication problems with elements connected to the I2C bus, but it can also indicate incorrect configuration or incorrect operation. In order to facilitate the diagnosis, a parameter was added to the error to determine which element is the problem. This parameter is a collection of flags. Each flag is assigned to a specific item or erroneous state. The table below describes the meaning of each flag.

In the case of minives units, where the islands do not occur, the unit, the charger module and the flags, described in the table, are reported from which it is possible to obtain information on which fuse / fuse the error concerns.

miniVES / midiVES

Minives (xCharge-Buffanum)

Binary Sixteen Description

0x0800 blown power supply fuse
 0x1000 blown fuse of the CH1 or CH2 amplifier
 0x2000 battery fuse blown
 0x4000 blown fuse 48V (internal bus)

xCharge-Buffanum (BRD00012-01)

Binary hexadecimal fault type Description

0x0001 invalid state BOARD_FFLAG0, TBD
 0x0002 invalid state BOARD_FFLAG1, TBD
 0x0004 invalid state BOARD_FFLAG2, TBD
 0x0008 invalid state BOARD_FFLAG3, TBD
 0x0010 invalid state BOARD_FFLAG4, TBD
 0x0020 invalid state BOARD_FFLAG5, TBD

xNET_MINI-1Gb / WAN (BRD00010-01), xNET_MINI-1Gb / WAN / RS (BRD00011-01)

Binary hexadecimal fault type Description

0x0001 no communication PCA6416 (io_exp)
 0x0002 no communication PCA6408 (io_exp ctrl)
 0x0004 no communication PCA9548 (switch_i2c)
 0x0008 no communication PCA9546 (switch_i2c ctrl)
 0x0010 no communication AT24C02 (backplane eeprom)
 0x0020 no communication PCA6416 (keypad io_exp)
 0x0040 no communication MAX11601 (keypad adc)
 0x0080 no communication MCP4651 (pa_pot ch1)
 0x0100 no communication MCP4651 (pa_pot ch2)
 0x0200 no communication PCF2129 (RTC charger)
 0x0400 no communication PCA6416 (dip_sw)
 0x0800 no communication CDCE913 (vcxo)
 0x1000 no communication MCP4725 (vcxo_dac)
 0x2000 no communication ADAU1701 (sigmaDSP)

3. The size of memory card in the control unit compared to available length of the message played, recorded and the number of entries in reports

SD Card [MB]	512	1024	2048	4096	8192	16348	32768
System/CFG **	104	144	224	384	704	1344	2624
Audio Message 16 bit / 48 kS/s	110 (20 min)	220 (40 min)	440 (80 min)	880 (160 min)	1760 (320 min)	3520 (640 min)	7040 (1280 min)
Reports	6,5 (100 k)	13 (200 k)	26 (400 k)	52 (800 k)	104 (1600 k)	208 (3200 k)	416 (64000 k)
BlackBox	165 (60 min)	330 (120 min)	660 (240 min)	1320 (480 min)	2640 (960 min)	5280 (1920 min)	10560 (3840 min)
RecordMessage	75 (20 min)	150 (40 min)	300 (80 min)	600 (160 min)	1200 (320 min)	2400 (640 min)	4800 (1280 min)
Service/Debug/Logs	32	32	32	32	32	32	32

4. Software compatibility

The official versions possess three identification characters:

x.y.z

For the official version it is acceptable (but not preferred) to have four-character marking, but in this situation the last character always has to be zero "0":

x.y.z.0

Subsequent version numbers may only increase (in time), however increasing the number of the more significant character is always accompanied by resetting the less significant character.

The importance of the individual characters:

X (major number) – it is a so called major version. This number is changed only in special cases, while introducing major changes to the functioning and structure of the software.

It is forbidden to interchange software versions with different major number. Such a change could mean eg. change of the operating system, framework, core libraries, and will almost always results in a lack of backwards compatibility. Also, there is no guarantee of correct functioning of the hardware. In particular, substitution of software – even if successful – can cause permanent damages to the device. There is also no guarantee of proper functioning of the equipment after returning to the previous version of the software. Replacement of the software in this case should always be consulted with the software provider.

Y (API number / feature) – this number is always increased at the time when differences at the *Application Programming Interface* level occur – that is, very often when adding new functionality to the officially released version. Additional bug fixes may also appear but this is not a rule. Changing the number on the Y level due to other (e.g. new) functionality will usually mean the lack of full software compatibility, but does not exclude that the new functionality does not affect compatibility. Such a change ensures no damage to the equipment after replacing the software. Information of software backwards compatibility should always be provided during the official release.

Z (bug number) – number incremented always at the subsequent bug fixes. Compatibility of hardware and software backwards is guaranteed. There is no new functionality resulting in the lack of backwards compatibility. This means that the FW / SW is fully compatible when X.Y are the same (the difference being fixed errors or minor adjustments).

14. miniVES / midiVES system touchscreen user manual

The following instructions describe the available functions and how to operate them from the touch screen located on the front panel of the miniVES / midiVES control units.

14.1 Home screen (screen saver)

Control units in idle status display the start screen (screen saver) informing about the system status, control unit name, current date and time in the system.

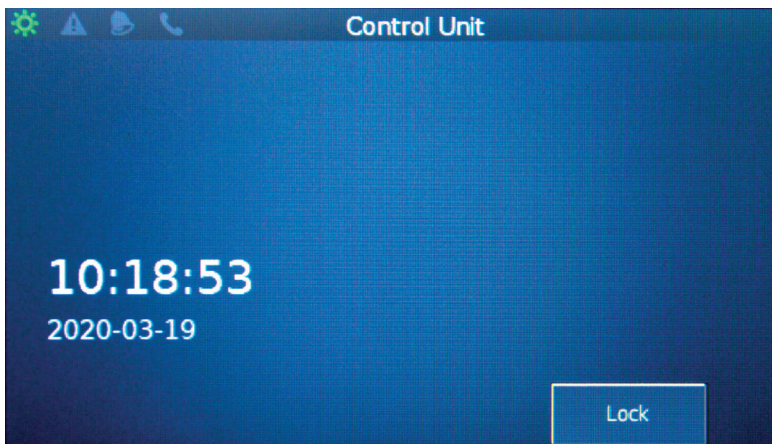

14.2 Lock screen

From the start screen (screen saver), we can use the **Lock** function, which allows you to set a password to access the screen. Touching the **Lock** icon displays an applet with which you can set a password consisting of one to six digits. The password has been confirmed with the **ENTER** icon.

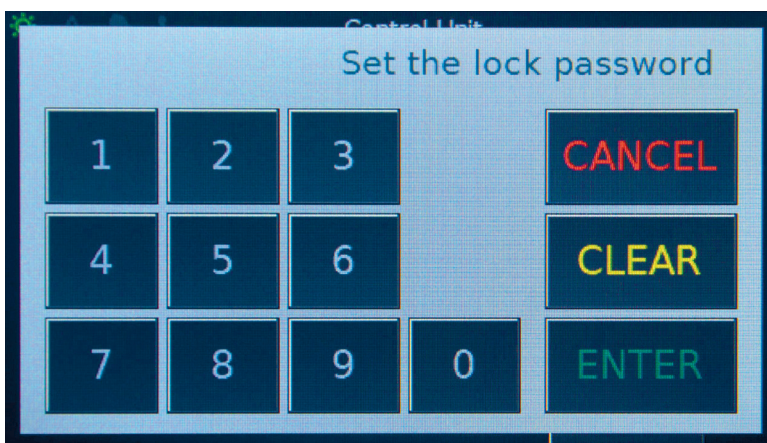

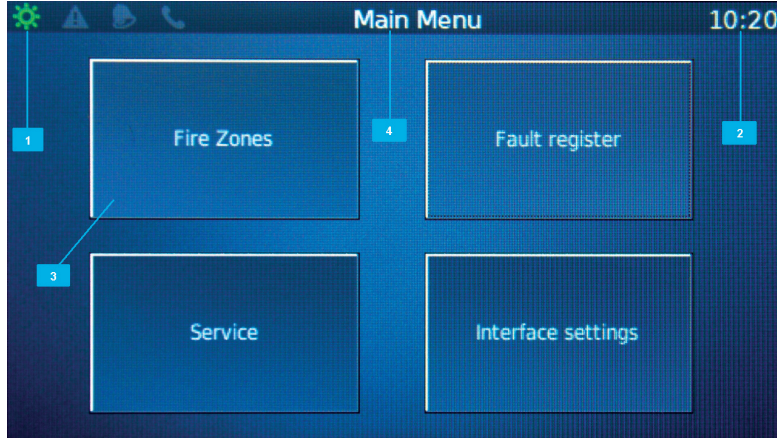

Once set, the lock password will be remembered by the system until you restore the factory settings from the Selector program.

14.3 System Options



1 System Status Icons

The top left field of the screen contains information about the current state of the miniVES / midiVES system.

When only the green power icon  is displayed, it means that the system is in normal mode (no Alarm) and no faults have been detected. Changing to a blue icon  means the system is in standby mode.

The triangle icon with an exclamation mark  indicates that internal mechanisms monitoring the state of the system have detected damage. Fault details are available after selecting the [Fault register](#) icon.

A red bell icon  means that the system is in alarm mode and only audio signals with Evacuation priority can be active.



2 The field displays the time of the internal system clock

3 The four main icons are used to navigate between the various functions available from the screen

4 The name of the displayed window

14.4 Fire zones

The **Fire Zones** tab allows you to matrix an audio message / input to a selected zone or fire zones, as well as to view the status of a given zone: failure, blocks, playback with information as to which source.

Note – the up/down arrow markings  and return  are carried out using the physical buttons located on the right side of the screen, not the icons themselves.



To matrix an audio source for a selected zone / zone group:

1. Select the icon(s) with the name of the zone or select the **Select all** icon – when selected, the icon(s) will turn yellow.
2. Select the **Source** icon:
Select the available audio input from the list or switch via the Messages icon to available messages loaded into the system's memory – select from the list and then select the **Play** icon.

This will create the matrix and activate it – the selected audio source will be played in the selected zones.
To stop playing the selected audio source, select the source again and press the **Stop** icon.

Audio Inputs window

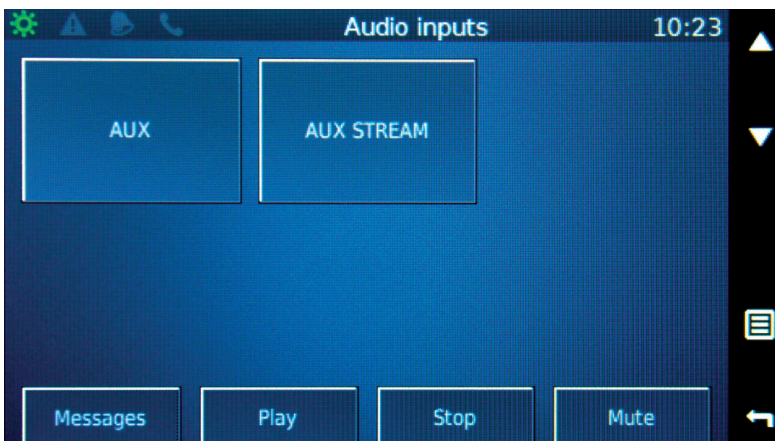

Message window



The **Mute** function is used to mute the audio source / message globally throughout the system. Select the source, the selected source will highlight in yellow and then select the **Mute** icon.

By clicking the back button located next to the icon  you will go to the main window **Fire Zones**, where we can verify if the zone selected by us plays the selected source (signaling within the zone icon).

Access to defined fire zone groups is displayed after selecting the **Group fire zones** icon from main menu **Fire Zones**.

In order to disable the zone (stop playing messages or audio inputs) or completely stop the possibility of playing any audio signal, select the zone / group (it will be highlighted in yellow) and then select the **Stop / Unblock**, which is located in the lower right corner of the **Fire Zones** screen. After selecting the appropriate option **Stop** or **Block / Unblock**, the function will be performed.

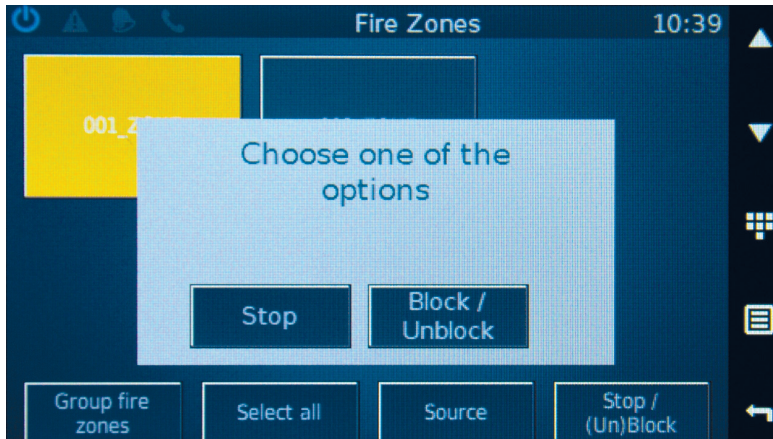

14.5 Numerical selection of fire zones

It is possible to select fire zones in the system using three-digit numbers.

To make this functionality active, you must give the zones names during the system configuration, including the three-digit prefix, according to the scheme XXX_zone name (e.g. 001_ZONE).



After opening the **Fire Zones** tab, use the button near this icon  to activate the numerical selection of the fire zone.

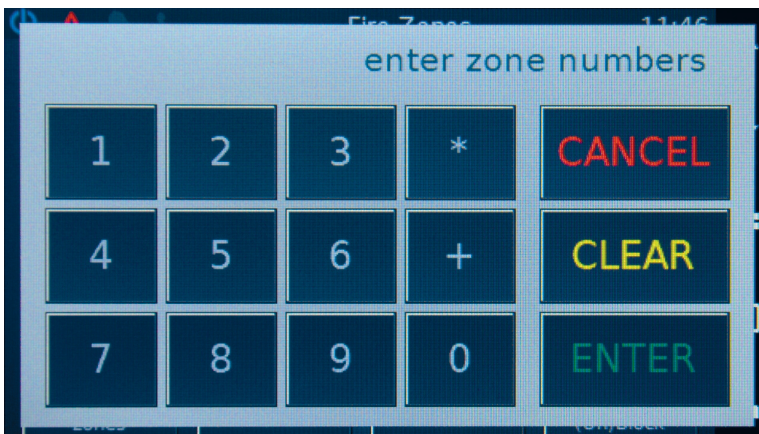

Enter the three-digit number of the fire zone and confirm with **ENTER** icon.

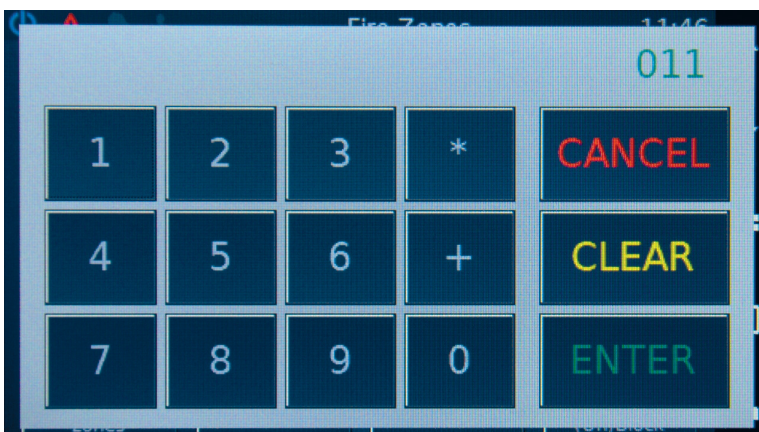

The fire zone we have chosen will be highlighted in yellow.



It is also possible to select several zones at the same time. To do this, enter the numbers of the selected zones, placing the + symbol between them.
 Example in the graphic below.

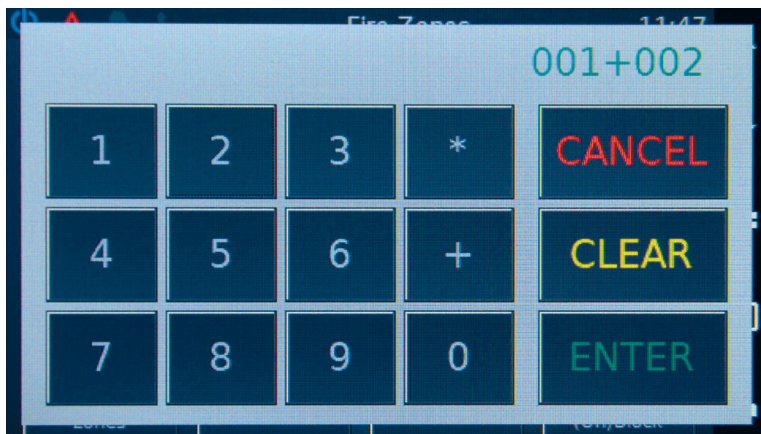

Operation is confirmed with the **ENTER** icon.

Another option for selecting fire zones allows you to select zones whose first elements of the name are common, e.g. all names starting with the syntax **01**. To do this, enter the syntax you want and add the symbol *****.

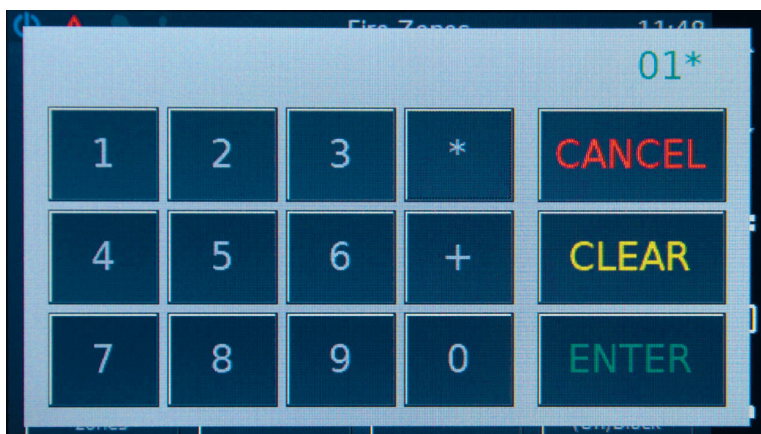

Operation is confirmed with the **ENTER** icon.

14.6 Fire zone groups



The [Group fire zone](#) icon allows you to open the screen with a view of the previously defined fire zone groups.



This tab allows you to perform the following actions:

- » check or uncheck a group of zones;
- » starting or stopping previously defined timers by selecting the timer (yellow color) and then using the [Start](#) or [Stop](#) icon; the timer status is signaled by a description within the timer icon;
- » select / deselect all fire zone groups ([Select all](#) icon).

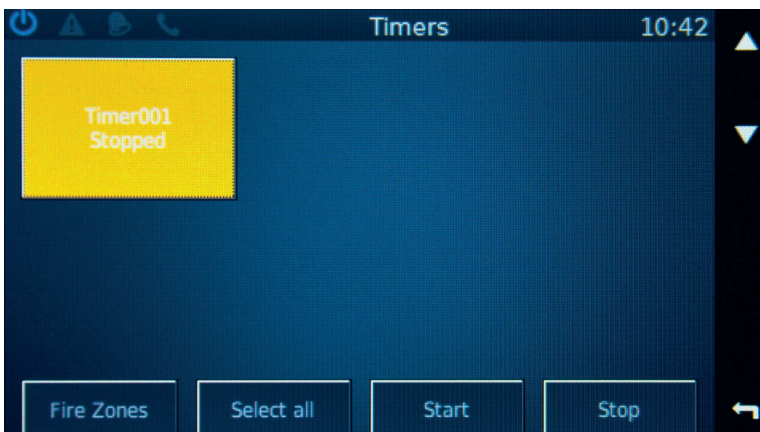

14.7 Service

The **Service – Misc functions** tab provides access to the basic functionalities needed for servicing or starting the system. Allows you to view impedance on each line of the control card, save impedance reference globally (on all cards) or on the selected output. It is also possible to generate an authorization code, swap zone microphones and fireman microphones in the event of physical substitution of devices, and to launch demonstration mode.

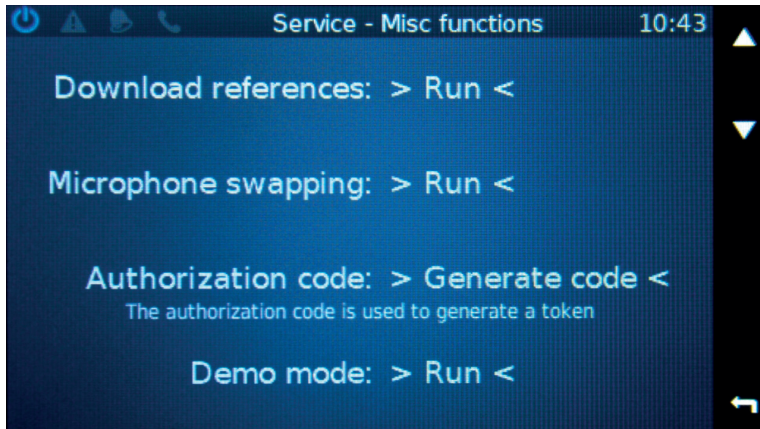

To download the impedance reference of the loudspeaker lines, select the **Run** field in the **Download reference** position:

In the **Line control** window, choice of control units with the buttons on the up / down . For initiate the process of downloading impedance reference values use **Save reference** icon.

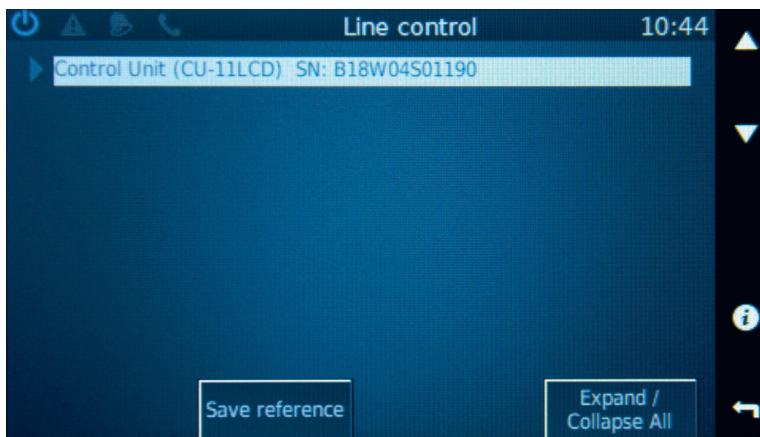

To view the current impedance on the selected control card, select the control unit, use the button, select the speaker line control card and use the button again.

To save the impedance reference on the selected control card, use the buttons up / down to select the control card and then use the icon **Save reference** – the impedance reference measured only on the speaker lines in the selected line control card will be saved.

The **Expand / Collapse All** icon displays the serial numbers of the speaker line control cards in all control units.

The **Microphone swapping** option is used to replace the configuration files of the zone microphones and the fireman in the case of substitution with a new one without configuration. In order to load the configuration into a new replacement microphone – e.g. a damaged one – select the **Run** field in to the **Microphone swapping** option. Then, using the up / down icons select from the list of unavailable devices the microphone that has been removed from the system (List of mic. undetected), then select the **List of new mic.** icon and select a new microphone that is active but has no configuration. Individual serial number of the microphone is used for identification. To assign a configuration, select the **Pair microphone** icon.

List of undetected microphones in the system



List of new microphones but without configuration



Code generation:

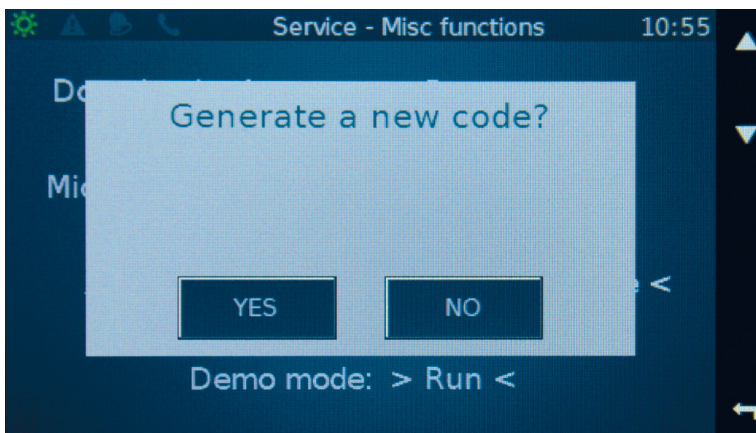

If the system configuration has been password protected and the password is unknown, there is a way to overwrite the old password by authorizing it in the configuration software using a token. After selecting the [Authorization code](#) option in the Service main menu, a 6-digit number will be displayed, which should be sent to Ambient System (support@ambientsystem.pl) to generate the authorization token.

Note: a request to generate an authorization token can only be sent by the system owner or manager or a person who obtains the written consent of the owner or manager and attaches it to an email.

From the Service window, use the buttons up/down to go to additional functions available on the GUI:

- » **Remote access.** It is an option that allows the system to connect to a remote server, where the simultaneous activation of remote access disconnects the local server enabling connection to a computer via Selector software. The connection time with the remote server is defined by clicking the time field and changing with the buttons up/down in the range from 15 minutes to 3 days.
- » **Service mode.** Unchecking the service mode will restrict access to system functions. If the service mode is turned off, it is only possible to select zones and activate audio sources from the touch screen.

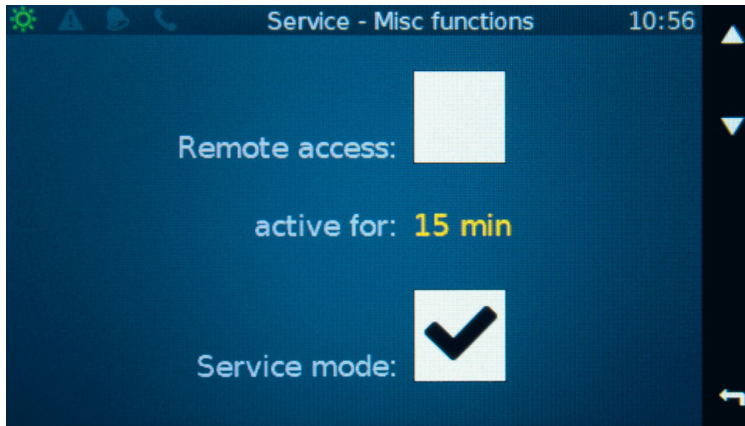

The service mode is reactivated after successive presses of four icons in the upper left corner of the display . It practically comes down to repeatedly sliding your finger on these icons until you see information about the activation of the service mode, which must be confirmed with the OK icon.

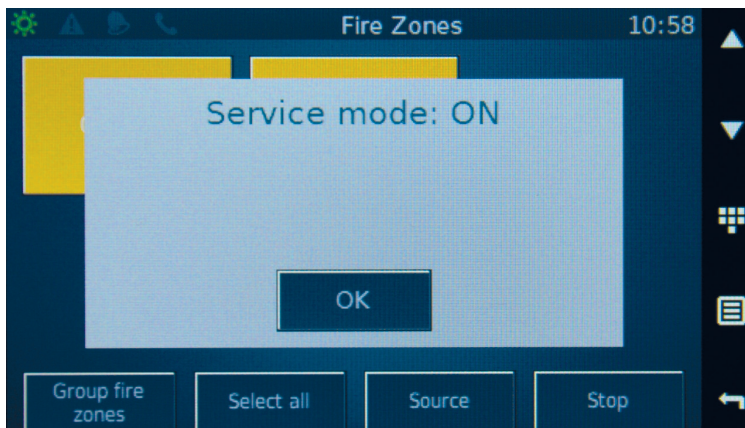

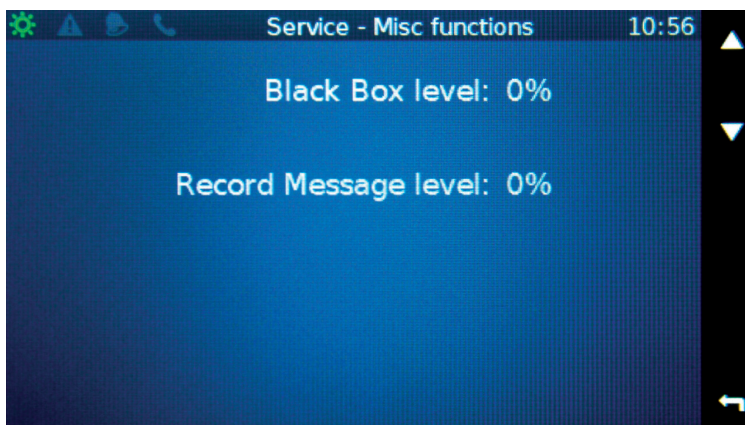

Selecting the "down" button again will take you to the last tab showing the occupation of the Record Message and Black Box buffers.



14.8 Fault register

The **Failure register** tab allows you to view the current damages detected by the system. The buttons located at the bottom of the screen allow viewing the failure history, sorting entries, confirming the fault (after confirming the fault acoustic signaling is turned off) and clearing the fault with calling the check function again.



Scroll the list of faults with the buttons up/down . The detailed description of the fault is displayed by pressing the information button . A detailed description of the information includes: notification number, error code, date and time of the fault occurrence, description of the fault and a detailed description of the device the fault relates to (control unit, card name, slot, line – assigned audio output).

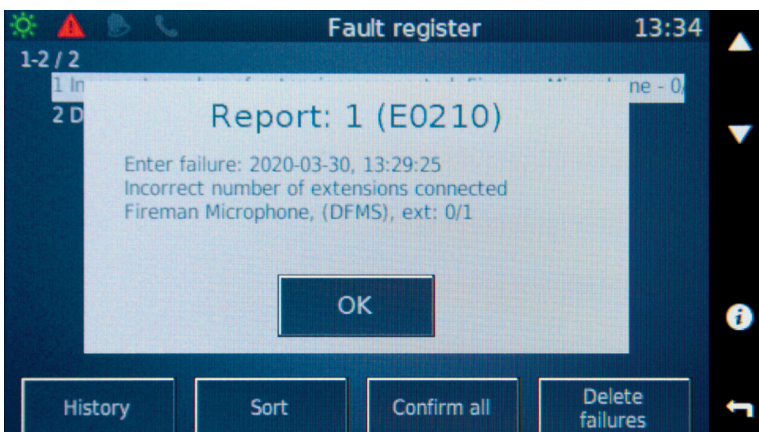

Selecting the **Sort** icon allows you to sort the damage list by date, module, unit, failure code.

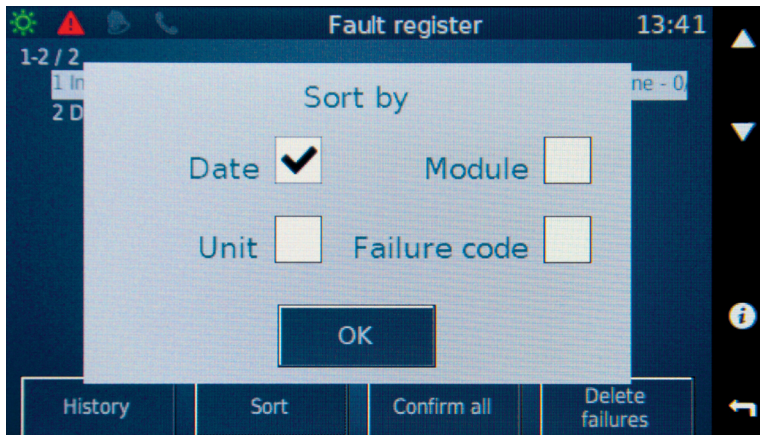

Selecting the **History** icon allows you to view past failures with the ability to view failure details, sort, filter by start date, and delete the registry.



Selecting the **Delete the register** icon clears all entries in the failure history. Deleting the history log has no effect on the system event log, available through the Selector program.

14.9 Interface setting

The [Interface settings](#) window is used to set the language in which the display is operated, change the time zone and display information about the expected IP address of the remote server, the signature of the system firmware version along with the project name.

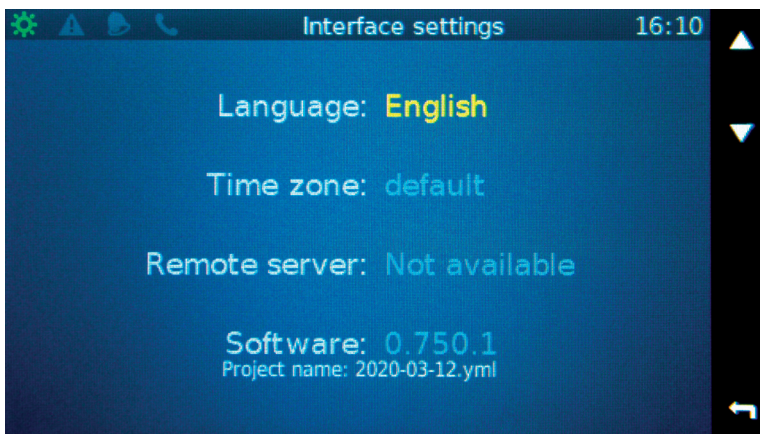

Screen timeout

Use the buttons up/down  to access the window activating the transition of the display to the energy saving mode. This function is natively active. It will cause that after 5 minutes from the last activity, the display will switch to the time and date view and after another 30 seconds, it will be completely blank.

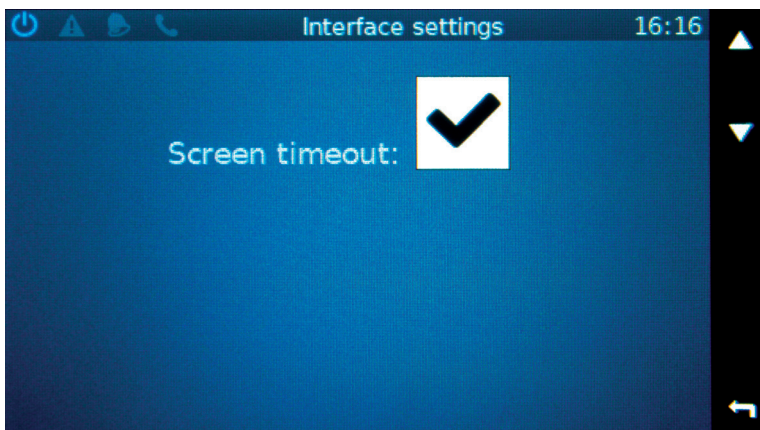

15. Annexes

- » List of certified switches to connect devices in CHAIN topology

16. Certificates

17. Glossary

AFL

Ambient Flex Language – internal script language based on LUA language. LUA is covered by X11 license.

AVB

Audio Video Bridging – technology of sending audio and video streams a computer network.

FACIE

Fire Alarm Control and Indicating Equipment – central part of fire signaling system powering fire detectors and receiving fire detection signals in order to trigger the alarm.

VASCU

Voice Alarm System Central Unit – central unit managing the voice alarm system.

TDM

Time-division multiplexing – method of realizing two or more communication channels in one transmission medium. Multiplexing allows limiting the number of transmission mediums.

18. List of tables

Table 1.	miniVES series 2001, 4001, 4002 and series 2001N, 4001N, 4002N technical data	22
Table 2.	miniVES series 2001L, 4001L, 4002L and series 2001LN, 4001LN, 4002LN technical data	27
Table 3.	midVES 8003R technical data	31
Table 4.	midVES series 8003LN, 8003LNR technical data	36
Table 5.	Technical parameters of ABT-xNET_mini-1Gb/WAN/RS communication card	41
Table 6.	Technical parameters of ABT-xNET_mini-1Gb communication card	42
Table 7.	Technical data of ABT-xCtrLine-4	44
Table 8.	Technical data of ABT-xCtrLine-2	46
Table 9.	Technical data of ABT-xCtrLine-44	49
Table 10.	Technical specifications of amplifier modules	63
Table 11.	Technical specification of the miniVES Charger card	65
Table 12.	Technical data of ABT-DFMS fireman microphone	69
Table 13.	Technical data of ABT-DMS zone microphone	73
Table 14.	Technical data of ABT-DMS-LCD zone microphone	76
Table 15.	Technical data of ABT-EKB-20M microphone extension	77
Table 18.	Technical data of ABT-M01 microphone	84
Table 19.	Colors signaling on the system microphones depending on the function assigned	103
Table 20.	LED colors of the button assigned to the function Select Zone	104
Table 21.	LED colors on the control unit front panel	105

19. List drawings

Drawing 1.	Diagram of the connector panel for miniVES series 2001, 4001 and 4002 units	20
Drawing 2.	Diagram of the connector panel for miniVES series 2001N, 4001N and 4002N units	21
Drawing 3.	Front panel of miniVES 2001, 4001, 4002 and 2001N, 4001N, 4002N series	23
Drawing 4.	Line control card arrangement for miniVES systems	24
Drawing 5.	Diagram of the connector panel for miniVES series 2001L, 4001L and 4002L units	25
Drawing 6.	Diagram of the connector panel for miniVES series 2001LN, 4001LN and 4002LN units	26
Drawing 7.	Front panel of miniVES 2001L, 4001L, 4002L and 2001LN, 4001LN, 4002LN, 4002LNR series	28
Drawing 8.	Line control card arrangement for miniVES systems	29
Drawing 9.	midiVES 8003R unit	30
Drawing 10.	Diagram of the connector panel for midiVES 8003R unit	31
Drawing 11.	Front panel of midiVES 8003R	33
Drawing 12.	Line control card arrangement for midiVES 8003R	34
Drawing 13.	midiVES 8003LR / 8003LNR	35
Drawing 14.	Diagram of the connector panel for midiVES series 8003LN, 8003LNR units	35
Drawing 15.	Front panel of midiVES 8003LN and 8003LNR series	37
Drawing 16.	Line control card arrangement for midiVES 8003LN, 8003LNR series	38
Drawing 17.	ABT-xNET_mini-1Gb/WAN/RS communication card	39
Drawing 18.	ABT-xNET_mini-1Gb/WAN/RS communication card	40
Drawing 19.	Diagram of logical inputs/outputs of communication card	40
Drawing 20.	ABT-xNET_mini-1Gb communication card	42
Drawing 21.	ABT-xCtrLine-4 loudspeaker lines control card	43
Drawing 22.	ABT-xCtrLine-4 loudspeaker lines control card	44
Drawing 23.	ABT-xCtrLine-2 card model	45
Drawing 24.	ABT-xCtrLine-2 card model	45
Drawing 25.	Impedance connection	47
Drawing 26.	Loop connection	47
Drawing 27.	ABT-xCtrLine-44 loudspeaker lines control card	48
Drawing 28.	ABT-xCtrLine-44 loudspeaker lines control card	48
Drawing 29.	LM8200 board	50
Drawing 30.	LM8200 – board for 4 loops	51
Drawing 31.	DDR-30L-24 – converter 48 VDC to 24 VDC	51
Drawing 32.	Control card line outputs connection in parallel with TF06 chokes to LM8200 board	52
Drawing 33.	Connecting 24VDC to LM8200	53

Drawing 34.	Connecting Fault Output to logical input available on mini and midIVES	54
Drawing 35.	Connection of isolators IS8200 to loop monitor board LM8200	56
Drawing 37.	Mounting rail assembly	59
Drawing 38.	Installation of rubber pads under 100V chokes	59
Drawing 39.	Assembly of 100V chokes and rubber pads	60
Drawing 40.	Installation of second 100V choke on top of a rubber pad	60
Drawing 41.	Fixing 100V chokes with a screw	60
Drawing 42.	Fixing 100V chokes with a M6 screw	61
Drawing 43.	Assembly of the remaining 100V chokes	61
Drawing 44.	Connecting each of the chokes to 100V output	61
Drawing 45.	Connecting 20V power supply to LM 8200	62
Drawing 46.	Installation of LM 8200 module and DC-DC converter on mounting rails	62
Drawing 47.	Connection between VRLA batteries, temp. sensor and miniVES Charger module	64
Drawing 48.	Connecting midIVES 8003LNR with 8003R with a set of 4x12V batteries	65
Drawing 49.	Microphone pins diagram	67
Drawing 50.	ABT-DFMS fireman microphone	68
Drawing 51.	Upper panel of fireman microphone	69
Drawing 52.	ABT-DMS zone microphone	71
Drawing 53.	ABT-DMS zone microphone connectors diagram	72
Drawing 54.	Zone microphone with ABT-DMS-LCD display	74
Drawing 55.	ABT-DMS-LCD zone microphone connectors diagram	75
Drawing 56.	ABT-EKB-20M microphone extension	77
Drawing 57.	The way of connecting microphone and extension using an aluminum connector	80
Drawing 60.	ABT-M01 main control placement	83
Drawing 61.	Microphone Connector pinout	83
Drawing 62.	Connecting the ABT-M01 microphone to miniVES	84
Drawing 63.	General connection diagram	85
Drawing 64.	Example of CHAIN topology control units connection	87
Drawing 65.	Example of power and lan configuration	88
Drawing 66.	Example of DIP Switch Configuration	88
Drawing 67.	Point to Point Connection Example 1	90
Drawing 68.	Point to Point Connection Example 2	90
Drawing 69.	RING topology control units connection (fiber connection)	91
Drawing 70.	RING topology control units connection (copper connection)	92
Drawing 71.	4x12 V DC VRLA storage batteries connecting diagram	93
Drawing 72.	Battery connection diagram	94
Drawing 73.	Fireman microphone optic fiber connection – RING topology	95

Drawing 74.	Fireman microphone cable connection – CHAIN topology	96
Drawing 75.	Fireman microphone powered through LAN PoE	96
Drawing 76.	Fireman microphone powered from 48 V auxillary power output	97
Drawing 77.	Fireman microphone powered by the fire power supply unit	97
Drawing 78.	Connecting zone microphone	98
Drawing 79.	Connecting zone microphone, fireman microphone	98
Drawing 80.	Connecting zone microphone – switch	99
Drawing 81.	Zone microphone powered by LAN PoE	100
Drawing 82.	Zone microphone powered by the auxillary 48 V power output on the connector panel of the miniVES unit	100
Drawing 83.	Zone microphone powered from an external source	100
Drawing 84.	ABT-NSC6 Noise Sensing Controller	159



We make everyday life safer

Ambient System Sp. z o.o.

ul. Bysewska 27 | 80-298 Gdańsk | Poland

T: +48 58 345 51 95 | ambient@ambientsystem.eu